

# TRP-C06

## User's Manual

### RS-232 to RS-422/485 Isolated Converter



Printed Feb. 2007 Rev 1.0

**Trycom Technology Co.,Ltd**  
1F, No.2-11,Sihu street ,Yingge Township, Taipei, Taiwan ROC  
Tel: 886-2-86781191 , Fax: 886-2-86781172  
Web: [www.trycom.com.tw](http://www.trycom.com.tw)

#### Copyright

Copyright Notice: The information in this manual is subject to change without prior notice in order to improve reliability, design and function and does not represent a commitment on the part of the manufacturer. No part of this manual may be reproduced, copied, or transmitted in any form without the prior written permission of manufacturer. Acknowledgment Products mentioned in this manual are mentioned for identification purpose only. Products names appearing in this manual may or may not be registered trademarks or copyright of their respective companies.

# 1. Introduction

The TRP-C06 allows RS-232 line signal to be bi-directionally converted to RS-422 or RS-485 standard and transmit data up to 1.2KM. Featuring automatic data format and baud rate detect function user just need to plug in the unit and go without extra configuration efforts. TRP-C06 is equipped with 3000V DC of isolation and internal surge protection on data lines to protect the host computer and converter against high voltage spikes, as well as ground potential differences. The industry standard DIN rail and panel mounting design enable user a fast and professional installation.

## 1-1. Features

- Wide input range DC power supply.
- Automatic data format configuration.
- Auto direction flow control on RS-485.
- Auto baud rate switching from 300bps to 115.2Kbps.
- 3000 VDC isolated protection.
- Surge protection on RS-422/485 data lines.
- Power/TX/RX mode LED indicator.
- Support screw terminal and external DC power adaptor.
- Din rail or panel mounts support.

## 1-2. Specifications

- Power input voltage: DC +10V to +30V.
- Host connection: Standard D-Sub 9 pin female connectors.
- RS-232 interface: Standard D-Sub 9 pin female connector
- RS-232 signal: TXD, RXD, GND.
- RS-422/485 interface: Industrial plug-in screw terminal.
- RS-485 signal: differential 2 half-duplex wires (DATA+, DATA-).
- RS-422 signal: differential 4 full-duplex wires.(TX+,RX+,TX-,RX-)
- Plug-in screw terminal wiring: Accepts AWG #12 ~30 wires.
- Transmission distance: RS-422/485 up to 4000ft. (1200M).
- Communication speed: from 300bps to 115.2Kbps.
- Isolation voltage: 3000V DC.
- Serial data format: Asynchronous data with any combination of bits, parity, stop.
- Signal LED: Power on, TX, and RX.
- Power supply: Screw terminal, or external DC adapter.
- Power consumption: 1.2 watt.
- Operating Temperature: 0 to 60°C .
- Storage Temperature: -20 to 70°C .
- Humidity: 10-90% non-condensing.
- Dimension: 151mm X 75mm X 26mm
- Weight: 375g.

## 2. Hardware description

### 2-1. TRP-C06 Panel Layout

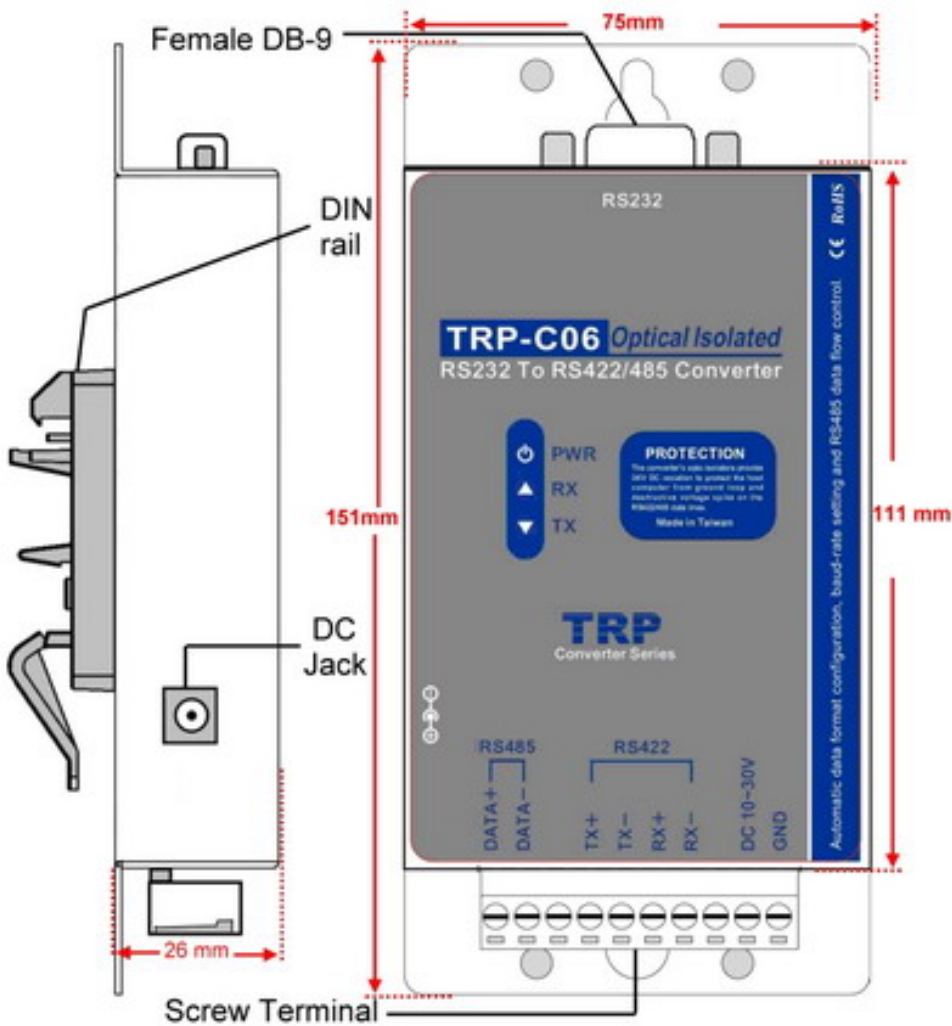

### 2-2. TRP-C06 Block Diagram

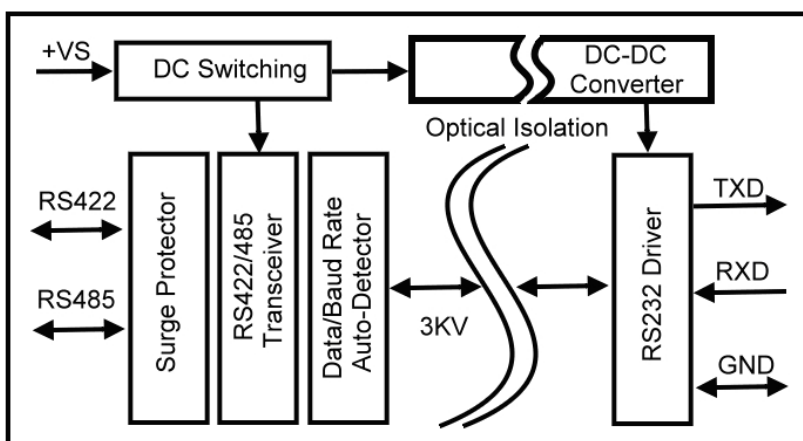

### 2-3. LED Indicator

**PWR LED:** System is ready.

**RX LED:** RS-232 receiving.

**TX LED:** RS-232 transmitting.

### 3. Install TRP-C06

#### 3-1. Power Connection

The TRP-C06 has a two pins terminal block and power jack. Power can be supplied from terminal block or external power adapter and supports wide input range from + 10~30V. When power is correctly supplied the PWR LED will lighting and indicates the system is up. It is highly recommended use the power jack specification 5.5\*2.1\*12mm, if the power supply is from external DC plug.

**Warning:** User can only choose one of following 2 power sources.

1. External DC adapter.
2. Screw terminal DC input

Do not use both power input simultaneously.

#### 3-2. RS-232 Female Pin Configuration for TRP-C06

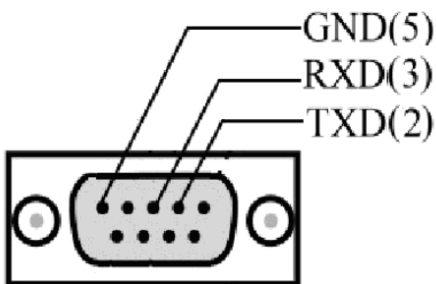

#### 3-3. RS-232 wiring connection

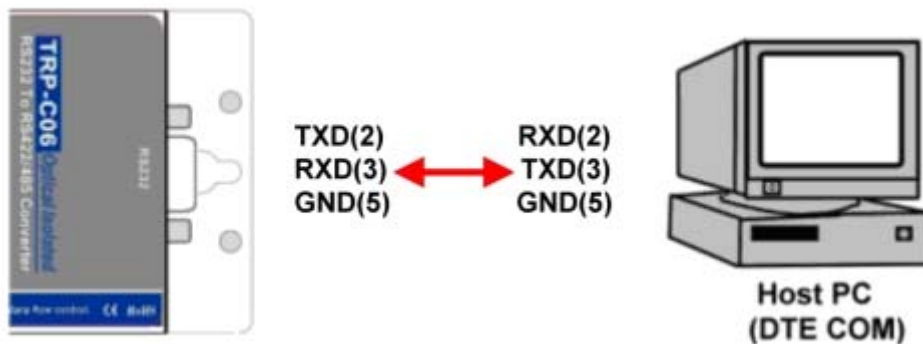

#### 3-4. RS-422 wiring connection

The TRP-C06 RS-422 mode supports 4 channels with full duplex operation for receive, transmit, and the data lines are in differential pairs. The wire connection is shown as

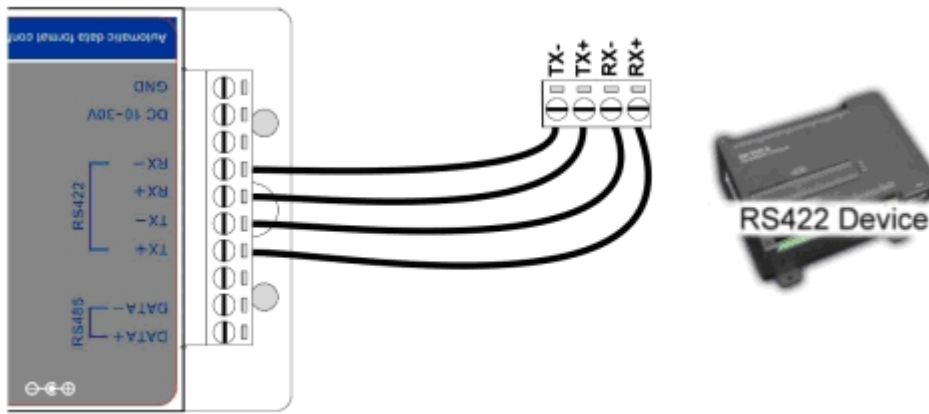

### 3-5. RS-485 wiring connection

The TRP-C06 RS-485 mode supports transmit and receive channels by using 2-wire half-duplex operation. The wire connection is shown as

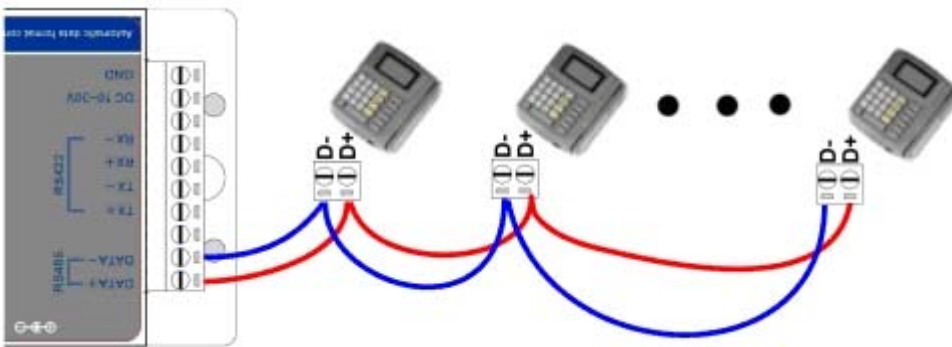

### 3-6. PC to RS-232 device by RS-422 wiring connection.



## 4. How to test TRP-C06

Trycom Technology Co., Ltd offers demo and TRPCOM test utility; these utilities may help user to demo and test TRP-C06 fast and easily. User may find the utilities in Trycom support CD or download from Trycom web [www.trycom.com.tw](http://www.trycom.com.tw). The testing utility includes

### RS-422 test utility:

Test422.exe for DOS  
 DEMO.exe for Windows

### RS-485 utility:

Test485.exe for DOS  
 TRPCOM for Windows

#### 4-1. RS-422 loop back test

Refer to wire connection as below

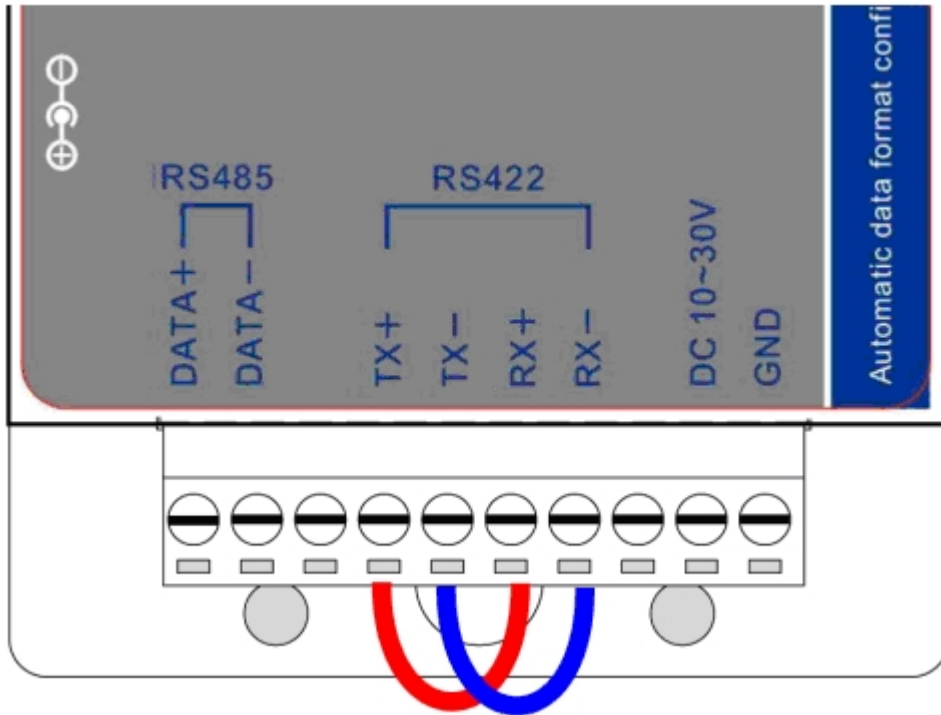

**STEP1:** Run the “DEMO.EXE” utility (See the Figure 1).

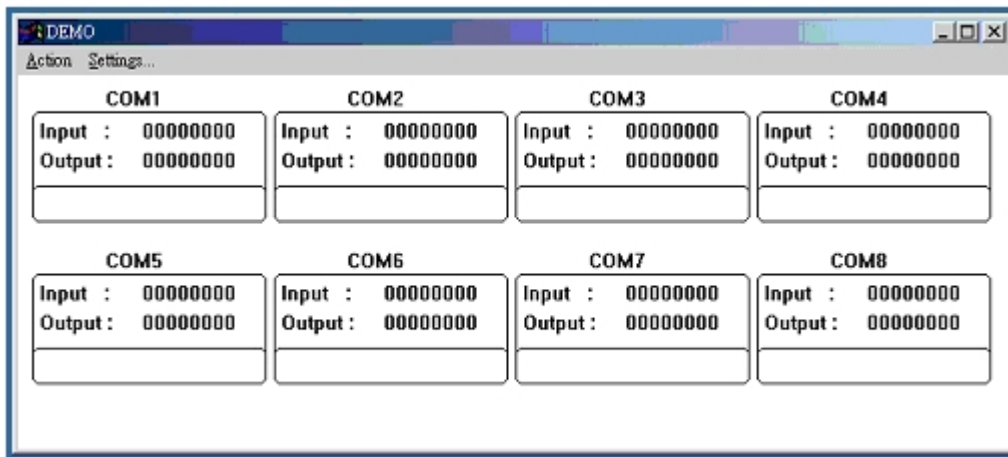

Fig.1

**STEP2:** Click the “Setting” to set the com port and baud rate (See the Figure 2); the demo setting screen will appear as Fig.2.



Fig.2

\*Please note: "COM3" is an example of COM port number; the real COM number is assigned by your PC..

**STEP3:** Click the "OK" the utility will show the input and output status.

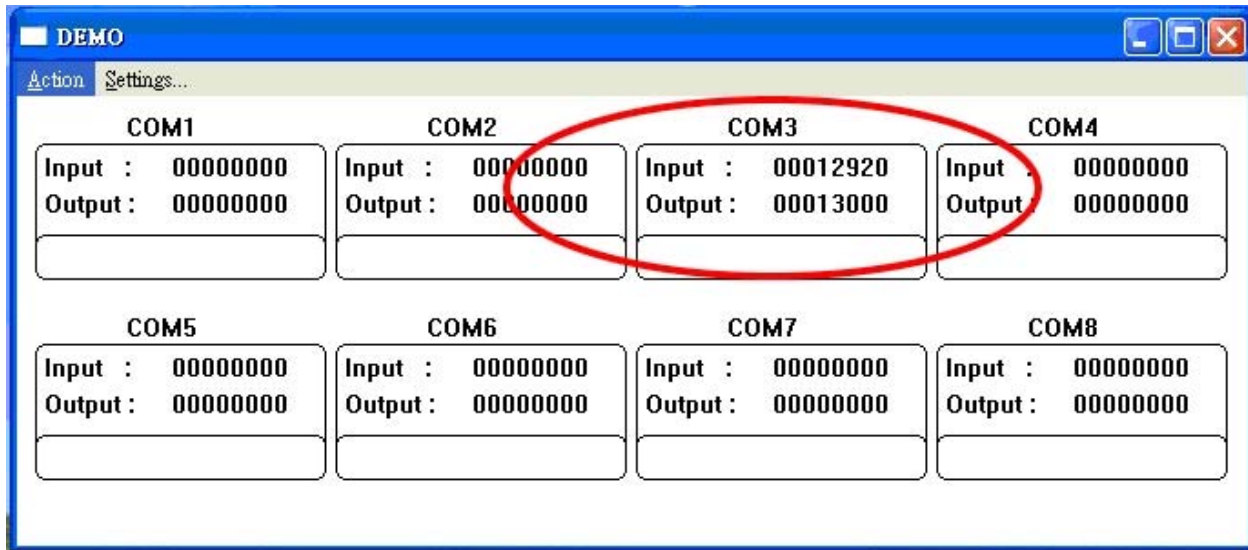

#### 4-2. RS485 test

Refer to 3-5 for RS-485 wire connection. User may also directly link TRP-C06 to Trycom Remote IO module, the wiring connection is as below.



**Step1.** Install TRPCOM utility.

TRPCOM is a test utility which may help user to test TRP-C06 with RS485 device easily. User may find the utility in the TRP-C06 support disk. Double click "setup.exe", the install Wizard will guide you to complete the installation.

**Step2.** Configure COM port and baud rate, after configuration press "OK" to the next screen.

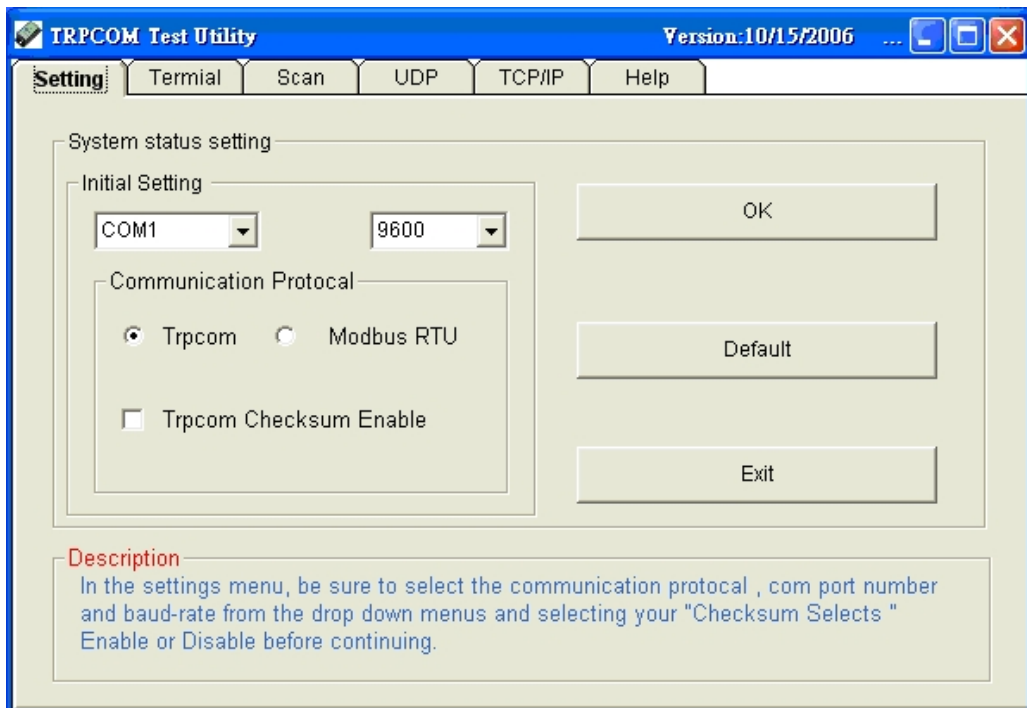

**Step3.** Send command "\$01M" and press "Send".

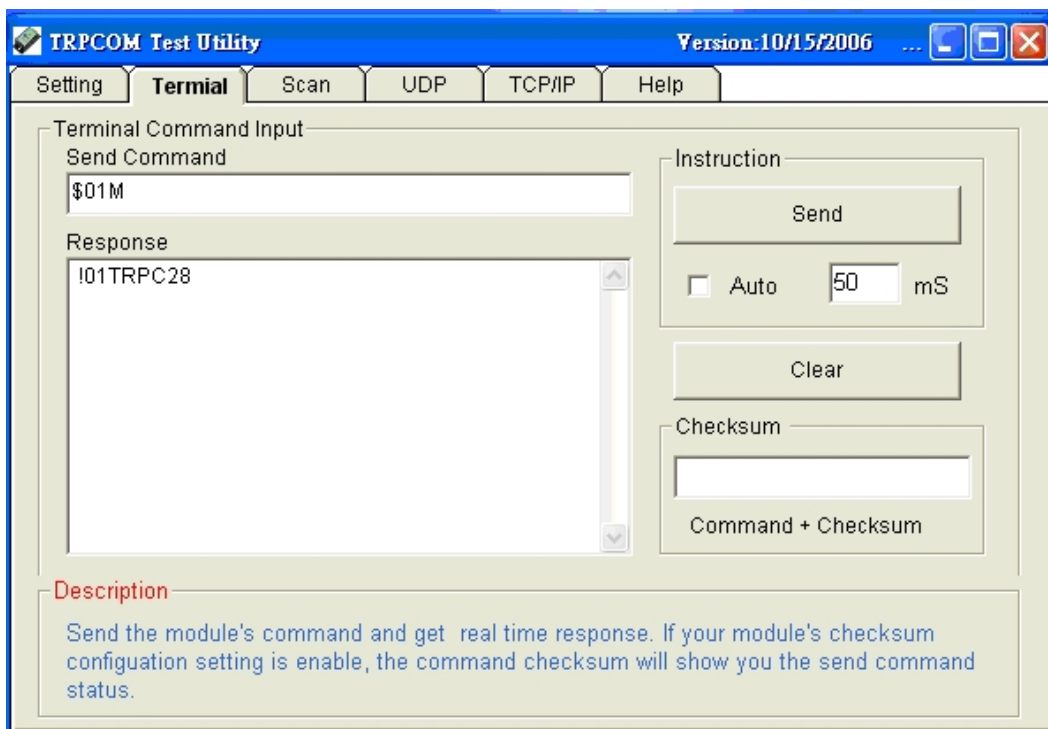

**Step4.** Data response received.

**Test complete.**