

Input Ranges :
9-75 VDC

Output Output:
Single Output

3.3V - 24V

Bipolar Output

±5.0V, ±12V, ±15V

Dual Output

+5.0V / +12V

Triple Output

+5.0V / ±12V

+5.0V / ±15V

Output Power:
6.6 to 15 W



The **D** series DC-DC converters feature high power density, high efficiency and excellent line & load regulation. Using innovative design technique, state-of-the-art Current Mode PWM control, and Surface Mount packaging & manufacturing technology, the D series provides up to 15 watts of well regulated power in a encapsulated 1.0" x 2.0" x 0.40" metal case with six-sided EMI/RFI shielding. Automatic feed forward compensation, pulse-by-pulse current limiting, and output short circuit protection are standard for all models.

These converters are designed for wide input range telecommunications, industrial and instrument applications. The wide input range (2:1 & 4:1) is ideal for battery or unregulated input applications.

No external components are needed for normal operation. Low ESR capacitors are used to minimize the conductive noise. This package is ideal for all I/O board system and distributed DC power configurations.

FEATURES

General:

- Small footprint : 1.0" x 2.0"
- Current-Mode Control
- Input/Output Isolation
- Input Voltage from 9 to 75Vdc
- 2:1 & 4:1 Input Voltage Range
- High conversion efficiency: 80%
- Line & load regulation to ±1.0%
- Fixed operating frequency
- Six-Sided Shielding

Isolation:

- Isolation Voltage >500V

APPLICATIONS

- PoE (Power over Ethernet)
- Distributed Power Systems
- Workstations
- Computer Equipment
- Communications Equipment

TABLE OF CONTENTS :

| | |
|------------------------------|----|
| General Specifications | 2 |
| Single Output | 4 |
| Bipolar..... | 6 |
| Dual..... | 8 |
| Triple Output..... | 10 |

1. Absolute Maximum Ratings

Stresses in excess of the absolute maximum ratings can cause performance degradation, adversely effect longterm reliability, and cause permanent damage to the device.

| Parameter | Conditions / Description | Min | Max | Units |
|------------------------------|------------------------------------|------|------|-------|
| Input Voltage | | | | |
| Continuous | 12 | -0.3 | 20 | Vdc |
| | 24 | -0.3 | 38 | Vdc |
| | 48 | -0.3 | 78 | Vdc |
| | W24 | -0.3 | 38 | Vdc |
| | W48 | -0.3 | 78 | Vdc |
| Transient (100mSec.) | 12 | -0.3 | 22 | Vdc |
| | 24 | -0.3 | 40 | Vdc |
| | 48 | -0.3 | 80 | Vdc |
| | W-24 | -0.3 | 40 | Vdc |
| | W-48 | -0.3 | 80 | Vdc |
| Operating Temperature | All models, base plate temperature | -40 | +100 | °C |
| Storage Temperature | Ambient | -55 | +105 | °C |
| Isolation Voltage | Input to Output | | +700 | Vdc |

2. Input Specifications

| Parameter | Conditions / Description | Min | Nom | Max | Units |
|-------------------------------|--------------------------|-----|-----|-----|-------|
| Input Voltage | | | | | |
| Voltage Range (Continuous) | 12 | 9 | 12 | 18 | Vdc |
| | 24 | 18 | 24 | 36 | Vdc |
| | 48 | 36 | 48 | 75 | Vdc |
| | W-24 | 10 | 24 | 36 | Vdc |
| | W-48 | 18 | 48 | 75 | Vdc |

3. Enable (On-Off Control)

| Parameter | Conditions / Description | Min | Nom | Max | Units |
|-----------------------|--------------------------|------|-----|-----|-------|
| Enable Pin | | | | | |
| Open Circuit Voltage | | | 5 | | Vdc |
| Source Current | | | | 1 | mA |
| Positive Logic | Standard | | | | |
| On-Control | Logic High or Floating | 5.0 | | 18 | Vdc |
| Off-Control | | -0.5 | | 1.8 | Vdc |
| Negative Logic | Not Available | | | | |

* Enable pin can be left floating if not used.

4. Output Specifications

| Parameter | Conditions / Description | Min | Nom | Max | Units |
|-------------------------|----------------------------|-----|-----|------|-------|
| Voltage Accuracy | Please see table | | | | % |
| Output Current | Please see table | | | | Adc |
| Output Trim | Not Available | | | | %Vout |
| Over Voltage Protection | Not available | | | | Vdc |
| Line Regulation | | | | ±1.0 | %Vout |
| Load Regulation | | | | ±1.0 | %Vout |
| Transient Respoonse | 50% ± 25% step load change | | 200 | | µSec. |
| Ripple & Noise | Please see table | | | | mVp-p |
| Switching Frequency | | | 200 | | KHz |

5. Output Trim

| Parameter | Conditions / Description | Min | Nom | Max | Units |
|----------------------|--------------------------|-----|-----|-----|-------|
| Negative Trim | Standard | | | | |
| Trim Up | Trim Pin to (-)Vout | | | 10 | %Vdc |
| Trim Down | Trim Pin to (+)Vout | 10 | | | %Vdc |
| Positive Trim | Not Available | | | | |

* Trim pin can be left floating if not used

6. Environmental and Mechanical Specifications

| Parameter | Conditions / Description | Min | Nom | Max | Units |
|-------------------------|---|-----|----------|-------|--------|
| Operating Temperature | Case Temperature | -25 | | +95 | °C |
| Storage Temperature | | -40 | | +105 | °C |
| Temperature Coefficient | | | | ±0.02 | %/°C |
| Shock | Halfsine wave, 3 axes | 50 | | | g |
| Sinusoidal Vibration | GR-63-CORE, Section 5.4.2 | 1 | | | g |
| Humidity | Relative Humidity, Non-Condensing | | | 95 | %R.H. |
| Weight | | | 1.0 (28) | | Oz (g) |
| MTBF (calculated) | Bellcore TR-NWT-000332 method 1 - parts count | 0.5 | | | MHrs |

7. Isolation Specifications

| Parameter | Conditions / Description | Min | Nom | Max | Units |
|-----------------------|--------------------------|-----|-----|-----|-------|
| Isolation Voltage | | | | | |
| Input to Output | | 500 | | | Vdc |
| I/O to Case | | 300 | | | Vdc |
| Isolation Resistance | Input to Output | 10 | | | MΩ |
| Isolation Capacitance | Input to Output | | 3 | | nF |

| INPUT | | OUTPUT | | | | | | | | EFF. (typ.) | MODEL NO. |
|--------------------|-------------------------|-------------|-------|-------|-------------|------|----------------|--------|---|----------------|-----------|
| Nominal (Range) | Max. Output Power | Voltage (V) | | | Current (A) | | Ripple & Noise | | Over Load Protection | | |
| | | Set Point | Min.* | Max.* | Min. | Max. | Peak-Peak | R.M.S. | | | |
| 12 (9 - 18) | 6.6W | 3.30 | 3.20 | 3.40 | 0.2 | 2.0 | 50mV | 10mV | Pulse by Pulse Current Limiting | 78% | D10S1203 |
| | 10W | | 3.20 | 3.40 | 0.3 | 3.0 | 50mV | 10mV | | 78% | D15S1203 |
| | 10W | 5.00 | 4.90 | 5.10 | 0.2 | 2.0 | 75mV | 15mV | | 82% | D10S1205 |
| | 15W | | 4.90 | 5.10 | 0.3 | 3.0 | 75mV | 15mV | | 82% | D15S1205 |
| | 10W | 12.0 | 11.88 | 12.12 | 0.08 | 0.85 | 100mV | 20mV | | 84% | D10S1212 |
| | 15W | | 11.88 | 12.12 | 0.12 | 1.25 | 100mV | 20mV | | 84% | D15S1212 |
| | 10W | 15.0 | 14.85 | 15.15 | 0.06 | 0.65 | 120mV | 25mV | | 84% | D10S1215 |
| | 15W | | 14.85 | 15.15 | 0.1 | 1.0 | 120mV | 25mV | | 84% | D15S1215 |
| | 10W | 24.0 | 23.76 | 24.24 | 0.04 | 0.42 | 200mV | 35mV | | 84% | D10S1224 |
| | 15W | | 23.76 | 24.24 | 0.06 | 0.63 | 200mV | 35mV | | 84% | D15S1224 |
| 24 (18 - 36) | 6.6W | 3.30 | 3.20 | 3.40 | 0.2 | 2.0 | 50mV | 10mV | Pulse by Pulse Current Limiting | 78% | D10S2403 |
| | 10W | | 3.20 | 3.40 | 0.3 | 3.0 | 50mV | 10mV | | 78% | D15S2403 |
| | 10W | 5.00 | 4.90 | 5.10 | 0.2 | 2.0 | 75mV | 15mV | | 82% | D10S2405 |
| | 15W | | 4.90 | 5.10 | 0.3 | 3.0 | 75mV | 15mV | | 82% | D15S2405 |
| | 10W | 12.0 | 11.88 | 12.12 | 0.08 | 0.85 | 100mV | 20mV | | 84% | D10S2412 |
| | 15W | | 11.88 | 12.12 | 0.12 | 1.25 | 100mV | 20mV | | 84% | D15S2412 |
| | 10W | 15.0 | 14.85 | 15.15 | 0.06 | 0.65 | 120mV | 25mV | | 84% | D10S2415 |
| | 15W | | 14.85 | 15.15 | 0.1 | 1.0 | 120mV | 25mV | | 84% | D15S2415 |
| | 10W | 24.0 | 23.76 | 24.24 | 0.04 | 0.42 | 200mV | 35mV | | 84% | D10S2424 |
| | 15W | | 23.76 | 24.24 | 0.06 | 0.63 | 200mV | 35mV | | 84% | D15S2424 |
| 48 (36 - 75) | 6.6W | 3.30 | 3.20 | 3.40 | 0.2 | 2.0 | 50mV | 10mV | Pulse by Pulse Current Limiting | 78% | D10S4803 |
| | 10W | | 3.20 | 3.40 | 0.3 | 3.0 | 50mV | 10mV | | 78% | D15S4803 |
| | 10W | 5.00 | 4.90 | 5.10 | 0.2 | 2.0 | 75mV | 15mV | | 82% | D10S4805 |
| | 15W | | 4.90 | 5.10 | 0.3 | 3.0 | 75mV | 15mV | | 82% | D15S4805 |
| | 10W | 12.0 | 11.88 | 12.12 | 0.08 | 0.85 | 100mV | 20mV | | 84% | D10S4812 |
| | 15W | | 11.88 | 12.12 | 0.12 | 1.25 | 100mV | 20mV | | 84% | D15S4812 |
| | 10W | 15.0 | 14.85 | 15.15 | 0.06 | 0.65 | 120mV | 25mV | | 84% | D10S4815 |
| | 15W | | 14.85 | 15.15 | 0.1 | 1.0 | 120mV | 25mV | | 84% | D15S4815 |
| | 10W | 24.0 | 23.76 | 24.24 | 0.04 | 0.42 | 200mV | 35mV | | 84% | D10S4824 |
| | 15W | | 23.76 | 24.24 | 0.06 | 0.63 | 200mV | 35mV | | 84% | D15S4824 |
| W-24 (10 - 36) | 6.6W | 3.30 | 3.20 | 3.40 | 0.2 | 2.0 | 50mV | 10mV | Pulse by Pulse Current Limiting | 76% | DW10S2403 |
| | 10W | 5.00 | 4.90 | 5.10 | 0.2 | 2.0 | 75mV | 15mV | | 80% | DW10S2405 |
| | 10W | 12.0 | 11.88 | 12.12 | 0.08 | 0.85 | 100mV | 20mV | | 82% | DW10S2412 |
| | 10W | 15.0 | 14.85 | 15.15 | 0.06 | 0.65 | 120mV | 25mV | | 82% | DW10S2415 |
| | 10W | 24.0 | 23.76 | 24.24 | 0.04 | 0.42 | 200mV | 35mV | | 82% | DW10S2424 |
| W-48 (20 - 75) | 6.6W | 3.30 | 3.20 | 3.40 | 0.2 | 2.0 | 50mV | 10mV | Pulse by Pulse Current Limiting | 76% | DW10S4803 |
| | 10W | 5.00 | 4.90 | 5.10 | 0.2 | 2.0 | 75mV | 15mV | | 80% | DW10S4805 |
| | 10W | 12.0 | 11.88 | 12.12 | 0.08 | 0.85 | 100mV | 20mV | | 82% | DW10S4812 |
| | 10W | 15.0 | 14.85 | 15.15 | 0.06 | 0.65 | 120mV | 25mV | | 82% | DW10S4815 |
| | 10W | 24.0 | 23.76 | 24.24 | 0.04 | 0.42 | 200mV | 35mV | | 82% | DW10S4824 |

* Combined Line & Load Regulation.

Standard Pin-Out

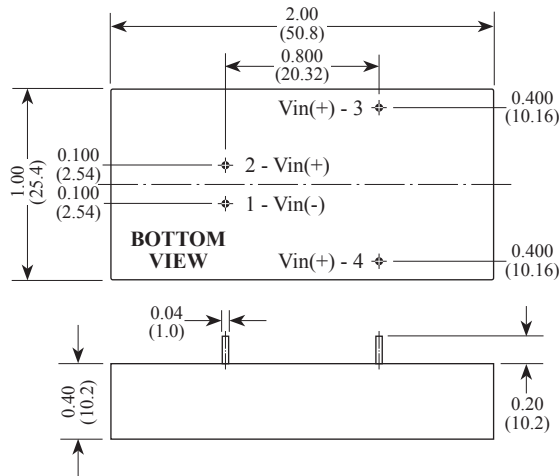

Alternate Pin-Out

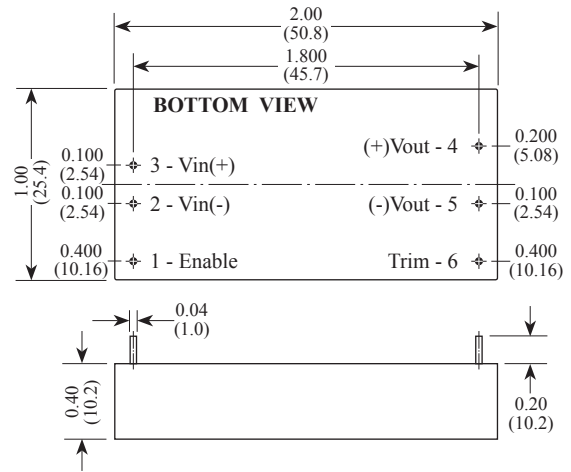

Product Numbering System & Selection Guide

| Series No. | Output Power | No Output | Input Voltage | Output Voltage | Options |
|------------|------------------------------------|-------------------|---|---|------------------------------|
| D | 10 : 10W 15 : 15W | S : Single | 12 : 9-18V 24 : 18-36V 48 : 36-75V | 03 : 3.3V 05 : 5.0V 12 : 12V 15 : 15V 24 : 24V | E : Alternate Pin-Out |
| DW | | | 24 : 10-36V | 15 : 15V | |
| DW | | | 48 : 20-75V | 24 : 24V | |

| INPUT | | OUTPUT | | | | | | | | | | Short Circuit Protection | Over Temp. Protect | EFF. (typ.) | MODEL NO. |
|--------------------|------------------------|-------------|--------------|--------|--------|-------------|------|-------|----------------|--------|------|---|--------------------------|----------------|-----------|
| Nominal (Range) | Max Output Power | Voltage (V) | | | | Current (A) | | | Ripple & Noise | | | | | | |
| | | # | Set Point | Min.* | Max.* | # | Min. | Max. | Peak-Peak | R.M.S. | | | | | |
| 12 (9-18) | 10W | ±5.0V | +V1 | +5.00 | +4.90 | +5.10 | +11 | +0.1 | +1.0 | 75mV | 15mV | Pulse by Pulse Current Limiting | Not Available | 82% | D10D1205 |
| | | | -V2 | -5.00 | -4.80 | +5.20 | -12 | -0.1 | -1.0 | 75mV | 15mV | | | 82% | D15D1205 |
| | 15W | ±5.0V | +V1 | +5.00 | +4.90 | +5.10 | +11 | +0.1 | +1.5 | 75mV | 15mV | | | 84% | D10D1212 |
| | | | -V2 | -5.00 | -4.80 | +5.20 | -12 | -0.1 | -1.5 | 75mV | 15mV | | | 84% | D15D1212 |
| | 10W | ±12V | +V1 | +12.00 | +11.90 | +12.10 | +11 | +0.04 | +0.42 | 100mV | 20mV | | | 84% | D10D1215 |
| | | | -V2 | -12.00 | -11.80 | +12.20 | -12 | -0.04 | -0.42 | 100mV | 20mV | | | 84% | D15D1215 |
| | 15W | ±12V | +V1 | +12.00 | +11.90 | +12.10 | +11 | +0.06 | +0.63 | 100mV | 20mV | | | 84% | D10D1215 |
| | | | -V2 | -12.00 | -11.80 | +12.20 | -12 | -0.06 | -0.63 | 100mV | 20mV | | | 84% | D15D1215 |
| | 10W | ±15V | +V1 | +15.00 | +14.85 | +15.15 | +11 | +0.03 | +0.34 | 120mV | 25mV | | | 84% | D10D1215 |
| | | | -V2 | -15.00 | -14.70 | -15.30 | -12 | -0.03 | -0.34 | 120mV | 25mV | | | 84% | D15D1215 |
| | 15W | ±15V | +V1 | +15.00 | +14.85 | +15.15 | +11 | +0.05 | +0.5 | 120mV | 25mV | | | 84% | D10D1215 |
| | | | -V2 | -15.00 | -14.70 | -15.30 | -12 | -0.05 | +0.5 | 120mV | 25mV | | | 84% | D15D1215 |
| 24 (18-36) | 10W | ±5.0V | +V1 | +5.00 | +4.90 | +5.10 | +11 | +0.1 | +1.0 | 75mV | 15mV | Pulse by Pulse Current Limiting | Not Available | 84% | D10D2405 |
| | | | -V2 | -5.00 | -4.80 | +5.20 | -12 | -0.1 | -1.0 | 75mV | 15mV | | | 84% | D15D2405 |
| | 15W | ±5.0V | +V1 | +5.00 | +4.90 | +5.10 | +11 | +0.1 | +1.5 | 75mV | 15mV | | | 86% | D10D2412 |
| | | | -V2 | -5.00 | -4.80 | +5.20 | -12 | -0.1 | -1.5 | 75mV | 15mV | | | 86% | D15D2412 |
| | 10W | ±12V | +V1 | +12.00 | +11.90 | +12.10 | +11 | +0.04 | +0.42 | 100mV | 20mV | | | 86% | D10D2415 |
| | | | -V2 | -12.00 | -11.80 | +12.20 | -12 | -0.04 | -0.42 | 100mV | 20mV | | | 86% | D15D2415 |
| | 15W | ±12V | +V1 | +12.00 | +11.90 | +12.10 | +11 | +0.06 | +0.63 | 100mV | 20mV | | | 86% | D10D2415 |
| | | | -V2 | -12.00 | -11.80 | +12.20 | -12 | -0.06 | -0.63 | 100mV | 20mV | | | 86% | D15D2415 |
| | 10W | ±15V | +V1 | +15.00 | +14.85 | +15.15 | +11 | +0.03 | +0.34 | 120mV | 25mV | | | 86% | D10D2415 |
| | | | -V2 | -15.00 | -14.70 | -15.30 | -12 | -0.03 | -0.34 | 120mV | 25mV | | | 86% | D15D2415 |
| | 15W | ±15V | +V1 | +15.00 | +14.85 | +15.15 | +11 | +0.05 | +0.5 | 120mV | 25mV | | | 86% | D10D2415 |
| | | | -V2 | -15.00 | -14.70 | -15.30 | -12 | -0.05 | +0.5 | 120mV | 25mV | | | 86% | D15D2415 |
| 48 (36 - 75) | 10W | ±5.0V | +V1 | +5.00 | +4.90 | +5.10 | +11 | +0.1 | +1.0 | 75mV | 15mV | Pulse by Pulse Current Limiting | Not Available | 84% | D10D4805 |
| | | | -V2 | -5.00 | -4.80 | +5.20 | -12 | -0.1 | -1.0 | 75mV | 15mV | | | 84% | D15D4805 |
| | 15W | ±5.0V | +V1 | +5.00 | +4.90 | +5.10 | +11 | +0.15 | +1.5 | 75mV | 15mV | | | 84% | D10D4812 |
| | | | -V2 | -5.00 | -4.80 | +5.20 | -12 | -0.15 | -1.5 | 75mV | 15mV | | | 84% | D15D4812 |
| | 10W | ±12V | +V1 | +12.00 | +11.90 | +12.10 | +11 | +0.04 | +0.42 | 100mV | 20mV | | | 86% | D10D4815 |
| | | | -V2 | -12.00 | -11.80 | +12.20 | -12 | -0.04 | -0.42 | 100mV | 20mV | | | 86% | D15D4815 |
| | 15W | ±12V | +V1 | +12.00 | +11.90 | +12.10 | +11 | +0.06 | +0.63 | 100mV | 20mV | | | 86% | D10D4815 |
| | | | -V2 | -12.00 | -11.80 | +12.20 | -12 | -0.06 | -0.63 | 100mV | 20mV | | | 86% | D15D4815 |
| | 10W | ±15V | +V1 | +15.00 | +14.85 | +15.15 | +11 | +0.03 | +0.34 | 120mV | 25mV | | | 86% | D10D4815 |
| | | | -V2 | -15.00 | -14.70 | -15.30 | -12 | -0.03 | -0.34 | 120mV | 25mV | | | 86% | D15D4815 |
| | 15W | ±15V | +V1 | +15.00 | +14.85 | +15.15 | +11 | +0.05 | +0.5 | 120mV | 25mV | | | 86% | D10D4815 |
| | | | -V2 | -15.00 | -14.70 | -15.30 | -12 | -0.05 | +0.5 | 120mV | 25mV | | | 86% | D15D4815 |
| 24W (10-36) | 10W | ±5.0V | +V1 | +5.00 | +4.90 | +5.10 | +11 | +0.1 | +1.0 | 75mV | 15mV | Pulse by Pulse Current Limiting | Not Available | 80% | DW10D2405 |
| | | | -V2 | -5.00 | -4.80 | +5.20 | -12 | -0.1 | -1.0 | 75mV | 15mV | | | 82% | DW10D2412 |
| | 10W | ±12V | +V1 | +12.00 | +11.90 | +12.10 | +11 | +0.04 | +0.42 | 100mV | 20mV | | | 82% | DW10D2415 |
| | | | -V2 | -12.00 | -11.80 | +12.20 | -12 | -0.04 | -0.42 | 100mV | 20mV | | | 82% | DW10D2415 |
| | 10W | ±15V | +V1 | +15.00 | +14.85 | +15.15 | +11 | +0.03 | +0.34 | 120mV | 25mV | | | 82% | DW10D4805 |
| | | | -V2 | -15.00 | -14.70 | -15.30 | -12 | -0.03 | -0.34 | 120mV | 25mV | | | 84% | DW10D4812 |
| 48W (20-75) | 10W | ±5.0V | +V1 | +5.00 | +4.90 | +5.10 | +11 | +0.1 | +1.0 | 75mV | 15mV | Pulse by Pulse Current Limiting | Not Available | 82% | DW10D4805 |
| | | | -V2 | -5.00 | -4.80 | +5.20 | -12 | -0.1 | -1.0 | 75mV | 15mV | | | 84% | DW10D4812 |
| | 10W | ±12V | +V1 | +12.00 | +11.90 | +12.10 | +11 | +0.04 | +0.42 | 100mV | 20mV | | | 84% | DW10D4815 |
| | | | -V2 | -12.00 | -11.80 | +12.20 | -12 | -0.04 | -0.42 | 100mV | 20mV | | | 84% | DW10D4815 |
| | 10W | ±15V | +V1 | +15.00 | +14.85 | +15.15 | +11 | +0.03 | +0.34 | 120mV | 25mV | | | 84% | DW10D4815 |
| | | | -V2 | -15.00 | -14.70 | -15.30 | -12 | -0.03 | -0.34 | 120mV | 25mV | | | 84% | DW10D4815 |

* Combined Line & Load (Low Line to High Line, Min. Load to Full Load)

Product Numbering System & Selection Guide

| | | | | |
|------------|------------------------------------|-----------------|---|---|
| D | 10 | D | 24 | 05 |
| Series No. | Output Power | No Output | Input Voltage | Output Voltage |
| D | 10 : 10W 15 : 15W | D : Dual | 12 : 9-18V 24 : 18-36V 48 : 36-75V | 05 : ±5.0V 12 : ±12V 15 : ±15V |
| DW | | | 24 : 10-36V | |
| DW | | | 48 : 20-75V | |

BLOCK DIAGRAM (Bipolar Output)

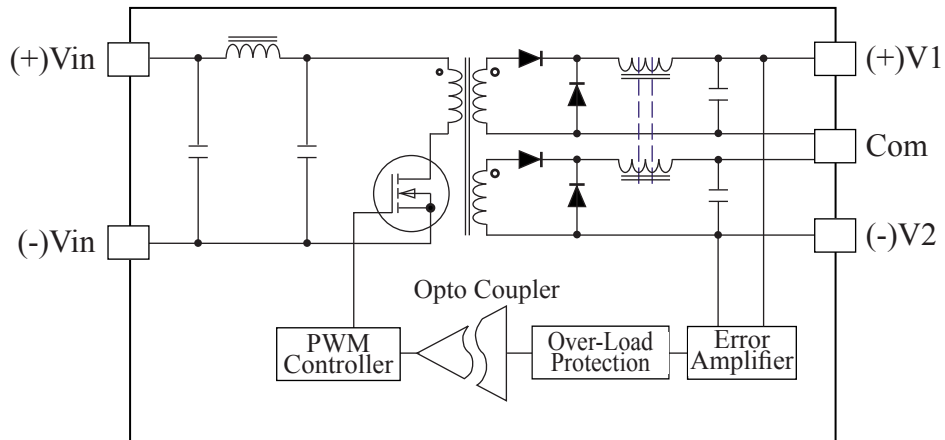

Standard Pin-Out (Bipolar Output)

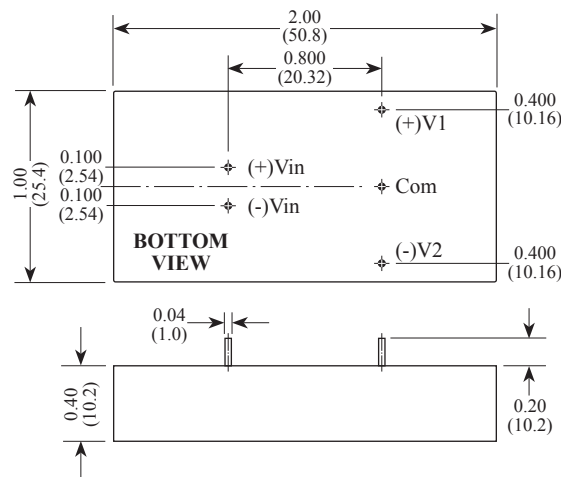

| INPUT | | OUTPUT | | | | | | | | | | Short Circuit Protection | Over Temp. Protect | EFF. (typ.) | MODEL NO. | | | | | | |
|-----------------|------------------|-------------|-----------|--------|--------|-------|-------------|-------|-----------|----------------|------|---------------------------------|--------------------|---------------------------------|---------------|---------------------------------|---------------|---------------------------------|---------------|-----|---------------|
| Nominal (Range) | Max Output Power | Voltage (V) | | | | | Current (A) | | | Ripple & Noise | | | | | | | | | | | |
| | | # | Set Point | Min.* | Max.* | # | Min. | Max. | Peak-Peak | R.M.S. | | | | | | | | | | | |
| 12 (9-18) | 10W | +5V | +V1 | +5.00 | +4.90 | +5.10 | +I1 | +0.1 | +1.5 | 75mV | 15mV | Pulse by Pulse Current Limiting | Not Available | 82% | D10D1205+12E | | | | | | |
| | | +12V | +V2 | +12.00 | +11.40 | +13.0 | +I2 | +0.04 | +0.42 | 120mV | 25mV | | | 82% | D15D1205+12E | | | | | | |
| | 15W | +5V | +V1 | +5.00 | +4.90 | +5.10 | +I1 | +0.15 | +2.0 | 75mV | 15mV | | | 84% | D10D2405+12E | | | | | | |
| | | +12V | +V2 | +12.00 | +11.40 | +13.0 | +I2 | +0.06 | +0.63 | 120mV | 25mV | | | 84% | D15D2405+12E | | | | | | |
| 24 (18-36) | 10W | +5V | +V1 | +5.00 | +4.90 | +5.10 | +I1 | +0.1 | +1.5 | 75mV | 15mV | | | Pulse by Pulse Current Limiting | Not Available | 84% | D10D2405+12E | | | | |
| | | +12V | +V2 | +12.00 | +11.40 | +13.0 | +I2 | +0.04 | +0.42 | 120mV | 25mV | | | | | 84% | D15D2405+12E | | | | |
| | 15W | +5V | +V1 | +5.00 | +4.90 | +5.10 | +I1 | +0.15 | +2.0 | 75mV | 15mV | | | | | 84% | D10D4805+12E | | | | |
| | | +12V | +V2 | +12.00 | +11.40 | +13.0 | +I2 | +0.06 | +0.63 | 120mV | 25mV | | | | | 84% | D15D4805+12E | | | | |
| W-24 (10-36) | 10W | +5V | +V1 | +5.00 | +4.90 | +5.10 | +I1 | +0.1 | +1.5 | 75mV | 15mV | | | | | Pulse by Pulse Current Limiting | Not Available | 80% | DW10D2405+12E | | |
| | | +12V | +V2 | +12.00 | +11.40 | +13.0 | +I2 | +0.04 | +0.42 | 120mV | 25mV | | | | | | | 82% | DW10D4805+12E | | |
| W-48 (20-75) | 10W | +5V | +V1 | +5.00 | +4.90 | +5.10 | +I1 | +0.1 | +1.5 | 75mV | 15mV | | | | | | | Pulse by Pulse Current Limiting | Not Available | 80% | DW10D2405+12E |
| | | +12V | +V2 | +12.00 | +11.40 | +13.0 | +I2 | +0.04 | +0.42 | 120mV | 25mV | | | | | | | | | 82% | DW10D4805+12E |

* Combined Line & Load (Low Line to High Line, Min. Load to Full Load)

Product Numbering System & Selection Guide

| | | | | | | | |
|------------|------------------------------------|-----------------|---|------------------|------------------|-----------|----------|
| D | 10 | D | 24 | 05 | + | 12 | E |
| Series No. | Output Power* | No Output | Input Voltage | +V1 Output | +V2 Outputs | Suffix | |
| D | 10 : 10W 15 : 15W | D : Dual | 12 : 9-18V 24 : 18-36V 48 : 36-75V | 05 : 5.0V | 12 : +12V | E: | Required |
| DW | | | 24 : 10-36V | | | | |
| DW | | | 48 : 20-75V | | | | |

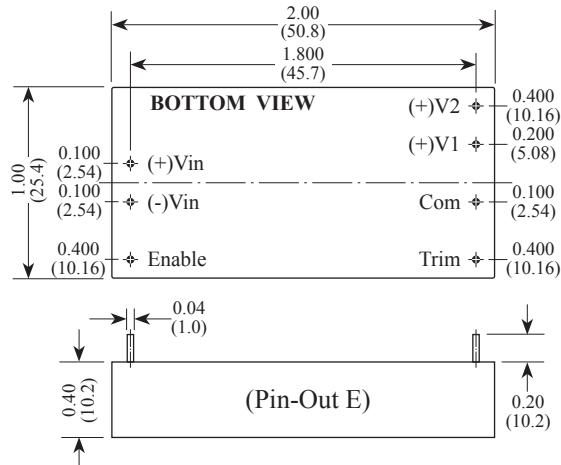
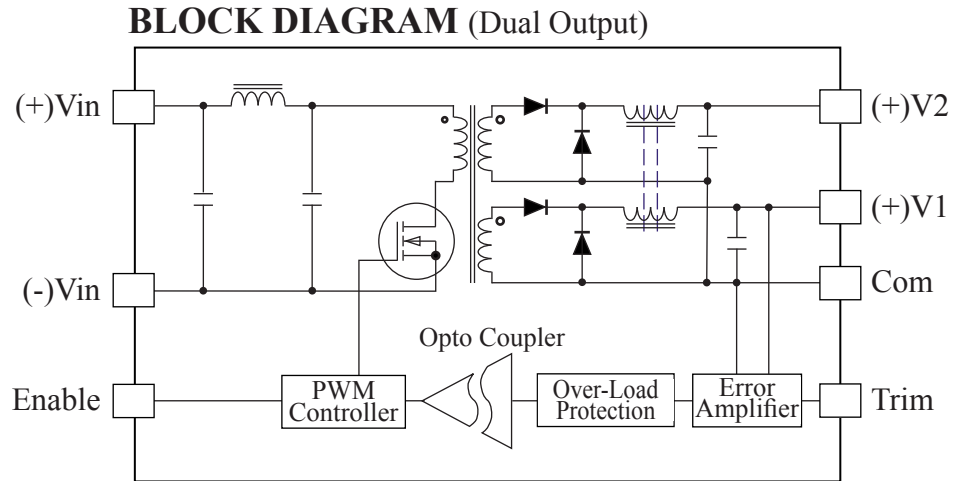

| INPUT | | OUTPUT | | | | | | | | | | Short Circuit Protection | Over Temp. Shutdown /Recover | EFF. (typ.) | MODEL NO. |
|-------------------|------------------|-------------|-----------|-------|-------|-------------|------|--------|----------------|--------|------|---------------------------------|------------------------------|-------------|--------------|
| Nominal (Range) | Max Output Power | Voltage (V) | | | | Current (A) | | | Ripple & Noise | | | | | | |
| | | # | Set Point | Min.* | Max.* | # | Min. | Max. | Peak-Peak | R.M.S. | | | | | |
| 12 (9 - 18) | 10W | +5.0V | +V1 | +5.00 | +4.90 | +5.10 | +11 | +0.1 | +1.0 | 75mV | 15mV | Pulse by Pulse Current Limiting | Not Available | 82% | D10T1205-12 |
| | | | +V3 | +12.0 | +11.4 | +13.0 | +12 | +0.02 | +0.21 | 100mV | 25mV | | | | |
| | | | -V2 | -12.0 | -11.4 | -13.0 | +13 | -0.02 | -0.21 | 100mV | 25mV | | | | |
| | 15W | ±12V | +V1 | +5.00 | +4.90 | +5.10 | +11 | +0.15 | +1.5 | 75mV | 15mV | | | 82% | D15T1205-12 |
| | | | +V3 | +12.0 | +11.4 | +13.0 | +12 | +0.02 | +0.32 | 100mV | 25mV | | | | |
| | | | -V2 | -12.0 | -11.4 | -13.0 | +13 | -0.02 | -0.32 | 100mV | 25mV | | | | |
| | 10W | +5.0V | +V1 | +5.00 | +4.90 | +5.10 | +11 | +0.1 | +1.0 | 75mV | 15mV | | | 82% | D10T1205-15 |
| | | | +V3 | +15.0 | +14.4 | +16.0 | +12 | +0.02 | +0.17 | 120mV | 30mV | | | | |
| | | | -V2 | -15.0 | -14.4 | -16.0 | +13 | -0.02 | -0.17 | 120mV | 30mV | | | | |
| | 15W | ±15V | +V1 | +5.00 | +4.90 | +5.10 | +11 | +0.15 | +1.5 | 75mV | 15mV | | | 82% | D15T1205-15 |
| | | | +V3 | +15.0 | +14.4 | +16.0 | +12 | +0.025 | +0.25 | 120mV | 30mV | | | | |
| | | | -V2 | -15.0 | -14.4 | -16.0 | +13 | -0.025 | -0.25 | 120mV | 30mV | | | | |
| 24 (18 - 36) | 10W | +5.0V | +V1 | +5.00 | +4.90 | +5.10 | +11 | +0.1 | +1.0 | 75mV | 15mV | Pulse by Pulse Current Limiting | Not Available | 83% | D10T2405-12 |
| | | | +V3 | +12.0 | +11.4 | +13.0 | +12 | +0.02 | +0.21 | 100mV | 25mV | | | | |
| | | | -V2 | -12.0 | -11.4 | -13.0 | +13 | -0.02 | -0.21 | 100mV | 25mV | | | | |
| | 15W | ±12V | +V1 | +5.00 | +4.90 | +5.10 | +11 | +0.15 | +1.5 | 75mV | 15mV | | | 83% | D15T2405-12 |
| | | | +V3 | +12.0 | +11.4 | +13.0 | +12 | +0.02 | +0.32 | 100mV | 25mV | | | | |
| | | | -V2 | -12.0 | -11.4 | -13.0 | +13 | -0.02 | -0.32 | 100mV | 25mV | | | | |
| | 10W | +5.0V | +V1 | +5.00 | +4.90 | +5.10 | +11 | +0.1 | +1.0 | 75mV | 15mV | | | 83% | D10T2405-15 |
| | | | +V3 | +15.0 | +14.4 | +16.0 | +12 | +0.02 | +0.17 | 120mV | 30mV | | | | |
| | | | -V2 | -15.0 | -14.4 | -16.0 | +13 | -0.02 | -0.17 | 120mV | 30mV | | | | |
| | 15W | ±15V | +V1 | +5.00 | +4.90 | +5.10 | +11 | +0.15 | +1.5 | 75mV | 15mV | | | 83% | D15T2405-15 |
| | | | +V3 | +15.0 | +14.4 | +16.0 | +12 | +0.025 | +0.25 | 120mV | 30mV | | | | |
| | | | -V2 | -15.0 | -14.4 | -16.0 | +13 | -0.025 | -0.25 | 120mV | 30mV | | | | |
| 48 (36 - 75) | 10W | +5.0V | +V1 | +5.00 | +4.90 | +5.10 | +11 | +0.1 | +1.0 | 75mV | 15mV | Pulse by Pulse Current Limiting | Not Available | 83% | D10T4805-12 |
| | | | +V3 | +12.0 | +11.4 | +13.0 | +12 | +0.02 | +0.21 | 100mV | 25mV | | | | |
| | | | -V2 | -12.0 | -11.4 | -13.0 | +13 | -0.02 | -0.21 | 100mV | 25mV | | | | |
| | 15W | ±12V | +V1 | +5.00 | +4.90 | +5.10 | +11 | +0.15 | +1.5 | 75mV | 15mV | | | 83% | D15T4805-12 |
| | | | +V3 | +12.0 | +11.4 | +13.0 | +12 | +0.02 | +0.32 | 100mV | 25mV | | | | |
| | | | -V2 | -12.0 | -11.4 | -13.0 | +13 | -0.02 | -0.32 | 100mV | 25mV | | | | |
| | 10W | +5.0V | +V1 | +5.00 | +4.90 | +5.10 | +11 | +0.1 | +1.0 | 75mV | 15mV | | | 83% | D10T4805-15 |
| | | | +V3 | +15.0 | +14.4 | +16.0 | +12 | +0.02 | +0.17 | 120mV | 30mV | | | | |
| | | | -V2 | -15.0 | -14.4 | -16.0 | +13 | -0.02 | -0.17 | 120mV | 30mV | | | | |
| | 15W | ±15V | +V1 | +5.00 | +4.90 | +5.10 | +11 | +0.15 | +1.5 | 75mV | 15mV | | | 83% | D15T4805-15 |
| | | | +V3 | +15.0 | +14.4 | +16.0 | +12 | +0.025 | +0.25 | 120mV | 30mV | | | | |
| | | | -V2 | -15.0 | -14.4 | -16.0 | +13 | -0.025 | -0.25 | 120mV | 30mV | | | | |
| W-24 (10 - 36) | 10W | +5.0V | +V1 | +5.00 | +4.90 | +5.10 | +11 | +0.1 | +1.0 | 75mV | 15mV | Pulse by Pulse Current Limiting | Not Available | 80% | DW10T2405-12 |
| | | | +V3 | +12.0 | +11.4 | +13.0 | +12 | +0.02 | +0.21 | 100mV | 25mV | | | | |
| | | | -V2 | -12.0 | -11.4 | -13.0 | +13 | -0.02 | -0.21 | 100mV | 25mV | | | | |
| | 10W | +5.0V | +V1 | +5.00 | +4.90 | +5.10 | +11 | +0.1 | +1.0 | 75mV | 15mV | | | 80% | DW10T2405-15 |
| | | | +V3 | +15.0 | +14.4 | +16.0 | +12 | +0.02 | +0.17 | 120mV | 30mV | | | | |
| | | | -V2 | -15.0 | -14.4 | -16.0 | +13 | -0.02 | -0.17 | 120mV | 30mV | | | | |
| W-48 (20 - 75) | 10W | +5.0V | +V1 | +5.00 | +4.90 | +5.10 | +11 | +0.1 | +1.0 | 75mV | 15mV | Pulse by Pulse Current Limiting | Not Available | 82% | DW10T4805-12 |
| | | | +V3 | +12.0 | +11.4 | +13.0 | +12 | +0.02 | +0.21 | 100mV | 25mV | | | | |
| | | | -V2 | -12.0 | -11.4 | -13.0 | +13 | -0.02 | -0.21 | 100mV | 25mV | | | | |
| | 10W | +5.0V | +V1 | +5.00 | +4.90 | +5.10 | +11 | +0.1 | +1.0 | 75mV | 15mV | | | 82% | DW10T4805-15 |
| | | | +V3 | +15.0 | +14.4 | +16.0 | +12 | +0.02 | +0.17 | 120mV | 30mV | | | | |
| | | | -V2 | -15.0 | -14.4 | -16.0 | +13 | -0.02 | -0.17 | 120mV | 30mV | | | | |

* Combined Line & Load (Low Line to High Line, Min. Load to Full Load)
(+V1 is Regulated and +V2/-V2 are Semi-Regulated.

Product Numbering System

| | | | | | | |
|------------|----------------------|------------|--|------------|----------|------------------------|
| D | 10 | T | 24 | 05 | - | 12 |
| Series No. | Output Power* | No Output | Input Voltage | +V1 Output | | +V2/-V3 Outputs |
| D | 10 : 10W 15 : 15W | T : Triple | 12 : 9-18V 24 : 18-36V 48 : 36-75V | 05 : 5.0V | | 12 : ±12V 15 : ±15V |
| DW | | | 24 : 10-36V 48 : 20-75V | | | |

BLOCK DIAGRAM

