

Input Ranges :

18-75 VDC

Output Output:

Single Output

1.2V - 80V

Dual Output

±5.0V - ±15V;

1.2V - 15V

Triple Output

1.2V - 15V,

±5.0V - ±15V

Quad Output

±5.0V - ±15V

Output Power:

15 to 50 W



FEATURES

General:

- Small footprint : 2.0" x 2.0"
- High output power : to 50 watts
- High output current : to 25 amps
- Wide input range : 18-75Vdc
- Open frame or Encapsulated
- Integral PCB transformer
- High conversion efficiency to 88%
- Line & load regulation to ±0.1%
- Fixed operating frequency

Protection:

- Output over-voltage protection
- Output over-load protection
- Hiccup mode short circuit protection
- Over-temperature protection
- Input under-voltage lock-out

Control:

- Enable (On/Off) Control
- Remote Sense
- Output Voltage Trim

Isolation:

- Isolation Voltage > 1500V

APPLICATIONS

- Distributed Power Systems
- Workstations
- Computer Equipment
- Communications Equipment

FH series is a family of 25W & 50W DC-DC converters with high power density, high efficiency, and high reliability. It provides in a compact 1.0" x 2.0" footprint. The 50W low voltage single output model is a dual phase design that achieves very low input reflected ripple current, fast output transient response and low output ripple & noise.

Integral PCB transformer / inductor is used for all models in this series. This new design technique has greatly improved the magnetic coupling, reduced switching spike and provided performance consistency. It also streamlines the production process by completely eliminating the hand-wind magnetic assembly process from production lines.

FH series provides the most extensive protection to safeguard both the power converter and the load. It includes output over-voltage protection, over-current protection, hiccup mode indefinite short circuit protection, under-voltage lockout and over-temperature protection. Over-current inception point is set at about 115% of rated load. Hiccup mode cycles at 28mSec period with 3mSec on and 25mSec off. Over-temperature shutdown activated at +115°C board temperature will recover when the temperature falls below +95°C.

FH series features low output noise, very tight line and load regulation, and high efficiency. There is no external capacitor requirement for normal operation. Output trim pin is standard. Sense pins are provided on low output voltage models for line drop compensation.

TABLE OF CONTENTS :

General Specifications	2
Single Output	4
Bipolar Output	6
Dual Output.....	8
Triple Output.....	12
Quad Output.....	16

1. Absolute Maximum Ratings

Stresses in excess of the absolute maximum ratings can cause performance degradation, adversely effect longterm reliability, and cause permanent damage to the device.

Parameter	Conditions / Description	Min	Max	Units
Input Voltage				
Continuous	12	-0.3	20	Vdc
	24	-0.3	36	Vdc
	48	-0.3	75	Vdc
	30	-0.3	30	Vdc
	60	-0.3	60	Vdc
Transient (100mSec.)	12	-0.3	22	Vdc
	24	-0.3	38	Vdc
	48	-0.3	78	Vdc
	30	-0.3	32	Vdc
	60	-0.3	64	Vdc
Operating Temperature	Standard temperature models, base plate temperature	-55	+105	°C
	Extended temperature models, base plate temperature	-55	+105	°C
Storage Temperature	Ambient	-55	+125	°C
Isolation Voltage	Input to Output		+2000	Vdc

2. Input Specifications

Parameter	Conditions / Description	Min	Nom	Max	Units
Input Voltage					
Voltage Range (Continuous)	12	10	12	20	Vdc
	24	18	24	36	Vdc
	48	36	48	75	Vdc
	30	10	24	30	Vdc
	60	20	48	60	Vdc
Under-Voltage Lockout (UVLO)					
Turn-On Threshold (Ramping Up)	12		9.7		Vdc
	24		17		Vdc
	48		35		Vdc
	30		9.7		Vdc
	60		17		Vdc
Turn-Off Threshold (Ramping Down)	12		9.7		Vdc
	24		16		Vdc
	48		33		Vdc
	30		9.2		Vdc
	60		16		Vdc

3. Enable (On-Off Control)

Parameter	Conditions / Description	Min	Nom	Max	Units
Enable Pin					
Open Circuit Voltage			10		Vdc
Source Current				1	mA
Positive Logic	Standard				
On-Control	Logic High or Floating	2.5		10	Vdc
Off-Control		-0.5		1.8	Vdc
Negative Logic	Not Available				

4. Output Trim

Parameter	Conditions / Description	Min	Nom	Max	Units
Negative Trim	Standard				
Trim Up	Trim Pin to (-)Vout			10	%Vdc
Trim Down	Trim Pin to (+)Vout	8			%Vdc
Positive Trim	Not Available				

*Trim pin can be left floating if not used.

5. Output Specifications

Parameter	Conditions / Description	Min	Nom	Max	Units
Voltage Accuracy	Please see table			±1.0	%
Output Current	Please see table				Adc
Output Trim				+10/-8	%Vout
Over Voltage Protection				120	%Vdc
Line Regulation				±0.1	%Vout
Load Regulation				±0.1	%Vout
Transient Response	50% ± 25% step load change		200		µSec.
Ripple & Noise	Please see table				mVp-p
Switching Frequency			300		KHz

6. Environmental and Mechanical Specifications

Parameter	Conditions / Description	Min	Nom	Max	Units
Operating Temperature	PCB Temperature				
Standard		-25		+100	°C
Extended		-55		+100	°C
Storage Temperature		-55		+125	°C
Temperature Coefficient				±0.02	%/°C
Shock	Halfsine wave, 3 axes	50			g
Sinusoidal Vibration	GR-63-CORE, Section 5.4.2	1			g
Humidity	Relative Humidity, Non-Condensing			95	%R.H.
Weight					
Open Frame			1.0(29)		Oz(g)
Encapsulated			2.0(58)		Oz(g)
MTBF (calculated)	Bellcore TR-NWT-000332 method 1 - parts count	1			MHrs

7. Isolation Specifications

Parameter	Conditions / Description	Min	Nom	Max	Units
Isolation Voltage					
Input to Output		1500			Vdc
I/O to Case		1500			Vdc
Isolation Resistance	Input to Output	10			MΩ
Isolation Capacitance	Input to Output		3		nF

8. Protections

Parameter	Conditions / Description	Min	Nom	Max	Units
Over-Load Protection					
Type	Current-Mode, Pulse by Pulse Current Limit				
Threshold	% Rated Load		120		%
Short-Circuit Protection					
Type	Hiccup Mode, Non-Latching, Auto-Recovery				
Threshold	Short-Circuit Resistance			65	mΩ
Over-Temperature Protection					
Type	Non-Latching, Auto-Recovery				
Threshold	PCB Temperature		115		°C
Hysteresis			15		°C
Over-Voltage Protection					
Type	Voltage Latch				
Set-Point				120	%Vout

BLOCK DIAGRAM

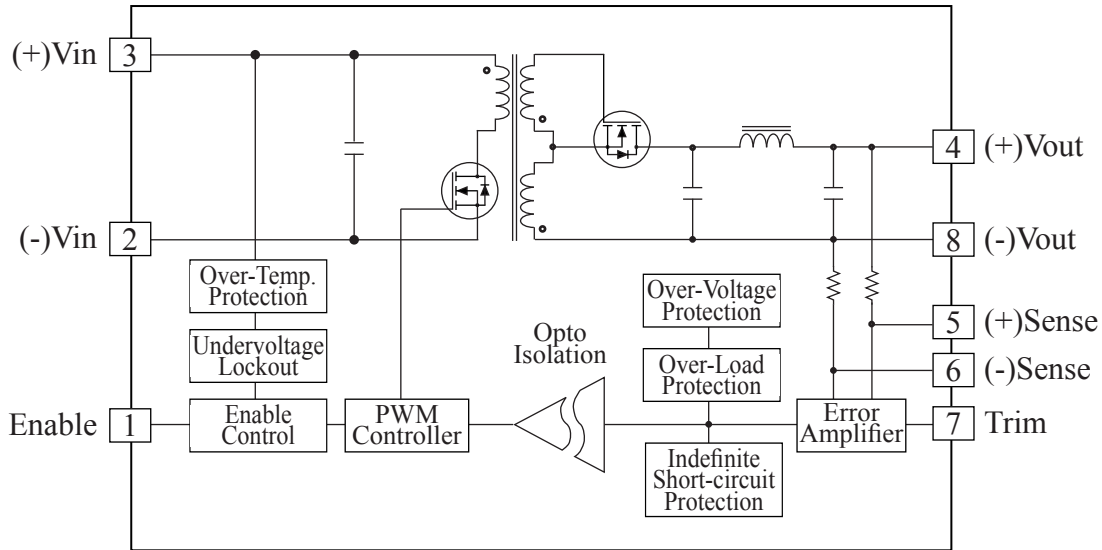

OPEN FRAME (Standard)

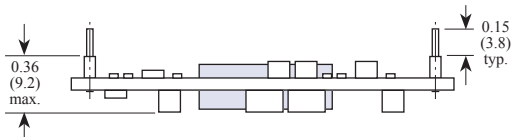
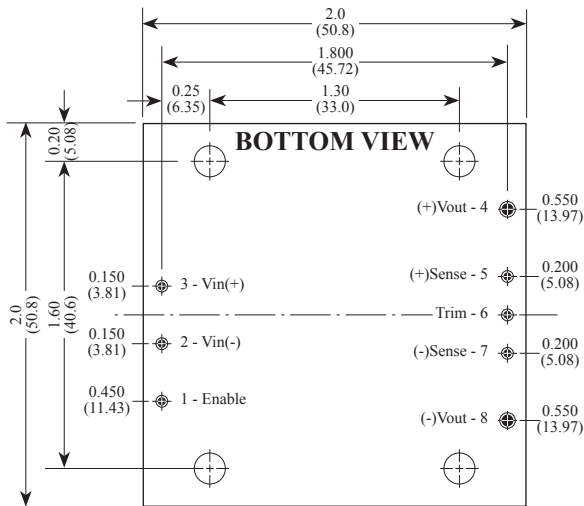

1. Pins 4, 8 are 0.060" (1.52mm) dia. with 0.085" (2.16mm) dia. standoff shoulders.
2. All other pins are 0.040" (1.0mm) dia. with 0.065" (1.65mm) dia. standoff shoulders.

ENCAPSULATED (Optional, MC Suffix)

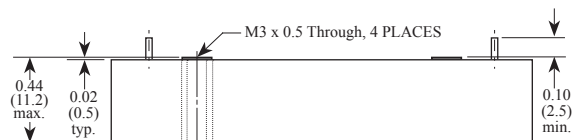
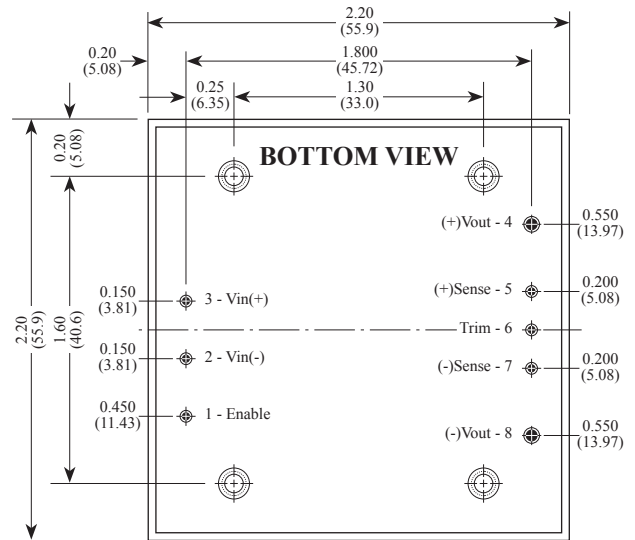

1. Pins 4, 8 are 0.060" (1.52mm) dia.
2. All other pins are 0.040" (1.02mm) dia.

INPUT			OUTPUT								Over Temp. Shutdown /Recover	EFF. (Typ.)	MODEL NO.		
Nominal (Range)	Under Voltage Lockout (typ.)		Voltage (V)			Current (A)		Ripple & Noise		OVP (max)				Short Circuit Protection	
	On	Off	Set Point	Min.*	Max.*	Min.	Max.	Peak-Peak	R.M.S.						
24 (18-36)	17.8	17.5	30	2.5	2.45	2.55	0	12.0	50mV	12mV	3.0V	Hiccup Mode Indefinite	+105°C/ +95°C	86%	FH30S24025
			50				0	20.0	50mV	12mV				86%	FH50S24025
			30	3.3	3.20	3.40	0	9.0	50mV	12mV	3.9V			88%	FH30S24033
			50				0	16.0	50mV	12mV				88%	FH50S24033
			30	5.0	4.90	5.10	0	6.0	75mV	15mV	5.9V			88%	FH30S2405
			50				0	10.0	75mV	15mV				88%	FH50S2405
			30	10.0	9.90	10.10	0.30	3.0	100mV	20mV	12.0V			88%	FH30S2410
			50				0.5	5.0	100mV	20mV				88%	FH50S2410
			30	12.0	11.88	12.12	0.25	2.50	100mV	20mV	14.4V			88%	FH30S2412
			50				0.4	4.20	100mV	20mV				88%	FH50S2412
			30	15.0	14.85	15.15	0.20	2.00	120mV	20mV	18.0V			88%	FH30S2415
			50				0.34	3.40	120mV	20mV				88%	FH50S2415
			50	48.0	47.50	48.50	0.1	1.05	400mV	50mV	57.6V			88%	FH50S2448
			50	60.0	59.0	61.0	0.08	0.84	500mV	60mV	72V			88%	FH50S2460
			50	80.0	79.0	81.0	0.06	0.63	600mV	80mV	96V			88%	FH50S2480
48 (36-75)	35	34	30	2.5	2.45	2.55	0	12.0	50mV	12mV	3.0V	Hiccup Mode Indefinite	+105°C/ +95°C	86%	FH30S48025
			50				0	20.0	50mV	12mV				86%	FH50S48025
			30	3.3	3.20	3.40	0	9.0	50mV	12mV	3.9V			88%	FH30S48033
			50				0	16.0	50mV	12mV				88%	FH50S48033
			30	5.0	4.90	5.10	0	6.0	75mV	15mV	5.9V			88%	FH30S4805
			50				0	10.0	75mV	15mV				88%	FH50S4805
			30	10.0	9.90	10.10	0.30	3.0	100mV	20mV	12.0V			88%	FH30S4810
			50				0.5	5.0	100mV	20mV				88%	FH50S4810
			30	12.0	11.88	12.12	0.25	2.50	100mV	20mV	14.4V			88%	FH30S4812
			50				0.4	4.20	100mV	20mV				88%	FH50S4812
			30	15.0	14.85	15.15	0.20	2.00	120mV	20mV	18.0V			88%	FH30S4815
			50				0.34	3.40	120mV	20mV				88%	FH50S4815
			50	48.0	47.50	48.50	0.1	1.05	400mV	50mV	57.6V			88%	FH50S4848
			50	60.0	59.0	61.0	0.08	0.84	500mV	60mV	72V			88%	FH50S4860
			50	80.0	79.0	81.0	0.06	0.63	600mV	80mV	96V			88%	FH50S4880
48W (18-75)	17.8	17.5	30	2.5	2.45	2.55	0	12.0	50mV	12mV	3.0V	Hiccup Mode Indefinite	+105°C/ +95°C	86%	FH30S48W025
			50				0	20.0	50mV	12mV				86%	FH50S48W025
			30	3.3	3.20	3.40	0	9.0	50mV	12mV	3.9V			88%	FH30S48W033
			50				0	16.0	50mV	12mV				88%	FH50S48W033
			30	5.0	4.90	5.10	0	6.0	75mV	15mV	5.9V			88%	FH30S48W05
			50				0	10.0	75mV	15mV				88%	FH50S48W05
			30	10.0	9.90	10.10	0.30	3.0	100mV	20mV	12.0V			88%	FH30S48W10
			50				0.5	5.0	100mV	20mV				88%	FH50S48W10
			30	12.0	11.88	12.12	0.25	2.50	100mV	20mV	14.4V			88%	FH30S48W12
			50				0.4	4.20	100mV	20mV				88%	FH50S48W12
			30	15.0	14.85	15.15	0.20	2.00	120mV	20mV	18.0V			88%	FH30S48W15
			50				0.34	3.40	120mV	20mV				88%	FH50S48W15
			50	48.0	47.50	48.50	0.1	1.05	400mV	50mV	57.6V			88%	FH50S48W48
			50	60.0	59.0	61.0	0.08	0.84	500mV	60mV	72V			88%	FH50S48W60
			50	80.0	79.0	81.0	0.06	0.63	600mV	80mV	96V			88%	FH50S48W80

* Combined Line & Load (Low Line to High Line, Min. Load to Full Load)

Product Numbering System & Selection Guide

FH	30	S	24	012	C
Series No.	Output Power	No Output	Input Voltage	Output Voltage	Options
FH	30 : 30W 50 : 50W	S : Single	24 : 18-36V 48 : 36-75V 48W : 18-75V	025 : 2.5V 033 : 3.3V 05 : 5.0V 10 : 10V 12 : 12V 48 : 48V 60 : 60V 80 : 80V	C : Extended Temperature MC : Encapsulated

BLOCK DIAGRAM

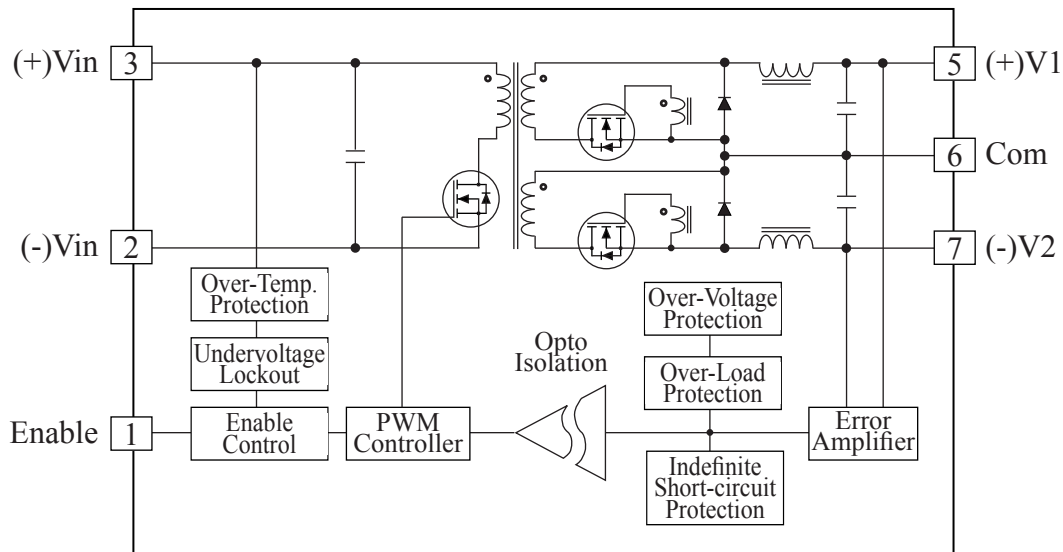

OPEN FRAME (Standard)

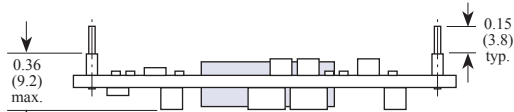
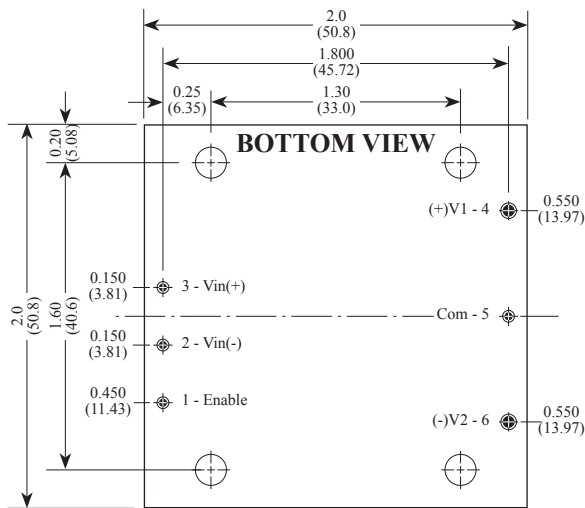

1. Pins 4, 6 are 0.060" (1.52mm) dia. with 0.085" (2.16mm) dia. standoff shoulders.
2. All other pins are 0.040" (1.0mm) dia. with 0.065" (1.65mm) dia. standoff shoulders.

ENCAPSULATED (Optional, MC Suffix)

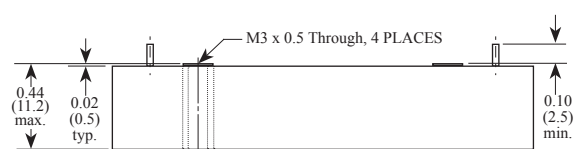
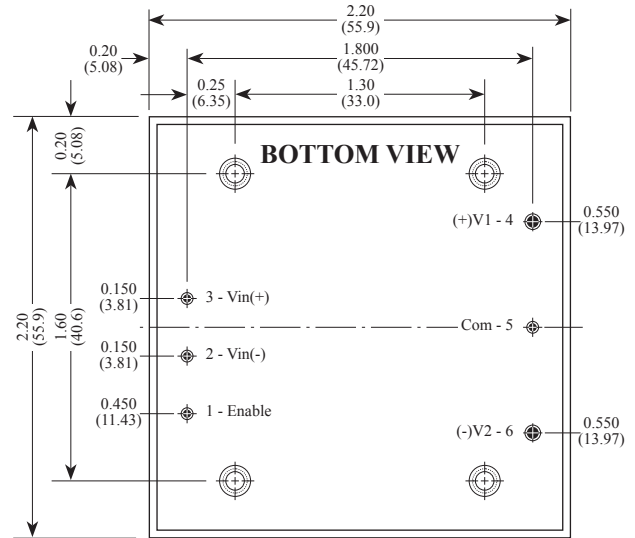

1. Pins 4, 6 are 0.060" (1.52mm) dia.
2. All other pins are 0.040" (1.02mm) dia.

INPUT			OUTPUT										Over Temp. Shutdown /Recover	EFF. (typ.)	MODEL NO.		
Nominal (Range)	Under Voltage Lockout (typ.)		Power (Watt)	Voltage				Current (A)			Ripple & Noise					Short Circuit Protection	
	On	Off		#	Set Point	Min.*	Max.*	#	Min.	Max.	Peak-Peak	R.M.S.					
24 (18-36)	17.8	17.5	30W	±5.0V	+V1	+5.00	+4.90	+5.10	+11	+0.3	+3.0	75mV	15mV	Hiccup Mode Indefinite	+105°C/ +95°C	88%	FH30D2405
					-V2	-5.00	-4.80	-5.20	-12	-0.3	-3.0	75mV	15mV				
			50W	±5.0V	+V1	+5.00	+4.90	+5.10	+11	+0.5	+5.0	75mV	15mV			88%	FH50D2405
					-V2	-5.00	-4.80	-5.20	-12	-0.5	-5.0	75mV	15mV				
			30W	±10V	+V1	+10.00	+9.90	+10.10	+11	+0.15	+1.5	100mV	20mV			88%	FH30D2410
					-V2	-10.00	-9.60	-10.40	-12	-0.15	-1.5	100mV	20mV				
	50W	±10V	+V1	+10.00	+9.90	+10.10	+11	+0.25	+2.5	100mV	20mV	88%	FH50D2410				
			-V2	-10.00	-9.60	-10.40	-12	-0.25	-2.5	100mV	20mV						
	30W	±12V	+V1	+12.00	+11.88	+12.12	+11	+0.1	+1.2	100mV	20mV	88%	FH30D2412				
			-V2	-12.00	-11.50	-12.50	-12	-0.1	-1.2	100mV	20mV						
	50W	±12V	+V1	+12.00	+11.88	+12.12	+11	+0.2	+2.1	100mV	20mV	88%	FH50D2412				
			-V2	-12.00	-11.50	-12.50	-12	-0.2	-2.1	100mV	20mV						
30W	±15V	+V1	+15.00	+14.85	+15.15	+11	+0.1	+1.0	120mV	25mV	88%	FH30D2415					
		-V2	-15.00	-14.40	-15.60	-12	-0.1	-1.0	120mV	25mV							
50W	±15V	+V1	+15.00	+14.85	+15.15	+11	+0.2	+1.7	120mV	25mV	88%	FH50D2415					
		-V2	-15.00	-14.40	-15.60	-12	-0.2	-1.7	120mV	25mV							
48 (36-75)	34	33	30W	±5.0V	+V1	+5.00	+4.90	+5.10	+11	+0.3	+3.0	75mV	15mV	Hiccup Mode Indefinite	+105°C/ +95°C	88%	FH30D4805
					-V2	-5.00	-4.80	-5.20	-12	-0.3	-3.0	75mV	15mV				
			50W	±5.0V	+V1	+5.00	+4.90	+5.10	+11	+0.5	+5.0	75mV	15mV			88%	FH50D4805
					-V2	-5.00	-4.80	-5.20	-12	-0.5	-5.0	75mV	15mV				
			30W	±10V	+V1	+10.00	+9.90	+10.10	+11	+0.15	+1.5	100mV	20mV			88%	FH30D4810
					-V2	-10.00	-9.60	-10.40	-12	-0.15	-1.5	100mV	20mV				
	50W	±10V	+V1	+10.00	+9.90	+10.10	+11	+0.25	+2.5	100mV	20mV	88%	FH50D4810				
			-V2	-10.00	-9.60	-10.40	-12	-0.25	-2.5	100mV	20mV						
	30W	±12V	+V1	+12.00	+11.88	+12.12	+11	+0.1	+1.2	100mV	20mV	88%	FH30D4812				
			-V2	-12.00	-11.50	-12.50	-12	-0.1	-1.2	100mV	20mV						
	50W	±12V	+V1	+12.00	+11.88	+12.12	+11	+0.2	+2.1	100mV	20mV	88%	FH50D4812				
			-V2	-12.00	-11.50	-12.50	-12	-0.2	-2.1	100mV	20mV						
30W	±15V	+V1	+15.00	+14.85	+15.15	+11	+0.1	+1.0	120mV	25mV	88%	FH30D4815					
		-V2	-15.00	-14.40	-15.60	-12	-0.1	-1.0	120mV	25mV							
50W	±15V	+V1	+15.00	+14.85	+15.15	+11	+0.2	+1.7	120mV	25mV	88%	FH50D4815					
		-V2	-15.00	-14.40	-15.60	-12	-0.2	-1.7	120mV	25mV							
48W (18-75)	17.8	17.5	30W	±5.0V	+V1	+5.00	+4.90	+5.10	+11	+0.3	+3.0	75mV	15mV	Hiccup Mode Indefinite	+105°C/ +95°C	86%	FH30D48W05
					-V2	-5.00	-4.80	-5.20	-12	-0.3	-3.0	75mV	15mV				
			50W	±5.0V	+V1	+5.00	+4.90	+5.10	+11	+0.5	+5.0	75mV	15mV			86%	FH50D48W05
					-V2	-5.00	-4.80	-5.20	-12	-0.5	-5.0	75mV	15mV				
			30W	±10V	+V1	+10.00	+9.90	+10.10	+11	+0.15	+1.5	100mV	20mV			86%	FH30D48W10
					-V2	-10.00	-9.60	-10.40	-12	-0.15	-1.5	100mV	20mV				
	50W	±10V	+V1	+10.00	+9.90	+10.10	+11	+0.25	+2.5	100mV	20mV	86%	FH50D48W10				
			-V2	-10.00	-9.60	-10.40	-12	-0.25	-2.5	100mV	20mV						
	30W	±12V	+V1	+12.00	+11.88	+12.12	+11	+0.1	+1.2	100mV	20mV	86%	FH30D48W12				
			-V2	-12.00	-11.50	-12.50	-12	-0.1	-1.2	100mV	20mV						
	50W	±12V	+V1	+12.00	+11.88	+12.12	+11	+0.2	+2.1	100mV	20mV	86%	FH50D48W12				
			-V2	-12.00	-11.50	-12.50	-12	-0.2	-2.1	100mV	20mV						
30W	±15V	+V1	+15.00	+14.85	+15.15	+11	+0.1	+1.0	120mV	25mV	86%	FH30D48W15					
		-V2	-15.00	-14.40	-15.60	-12	-0.1	-1.0	120mV	25mV							
50W	±15V	+V1	+15.00	+14.85	+15.15	+11	+0.2	+1.7	120mV	25mV	86%	FH50D48W15					
		-V2	-15.00	-14.40	-15.60	-12	-0.2	-1.7	120mV	25mV							

* Combined Line & Load Regulation (Low Line to High Line & Min. Load to Full Load)

Product Numbering System & Selection Guide

FH		50		D		24		10		C	
Series No.	Output Power	No Output		Input Voltage		Output Voltage		Options			
FH	30 : 30W 50 : 50W	D	Dual	12	10-20V	10	±10V	C	Extended Temperature		
				24	18-36V	12	±12V	MC	Encapsulated		
				48	36-75V	15	±15V				
				30	10-30V						
				60	20-60V						

BLOCK DIAGRAM

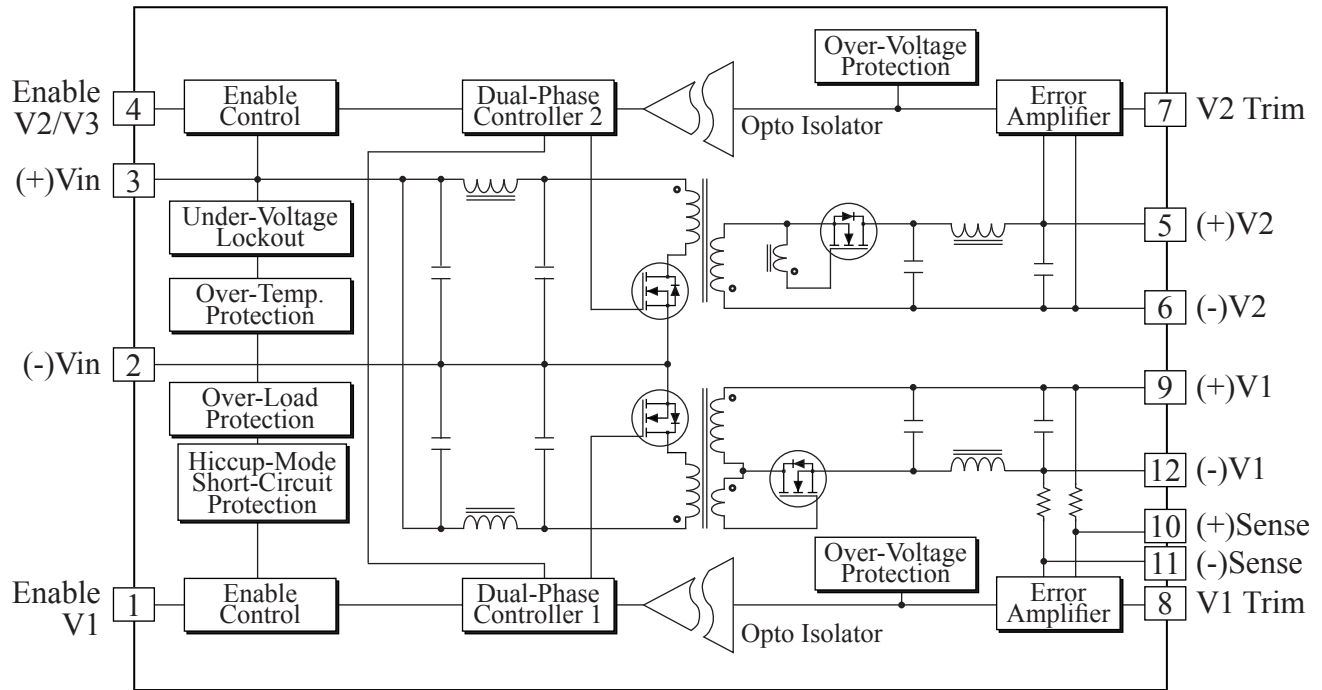

OPEN FRAME (Standard)

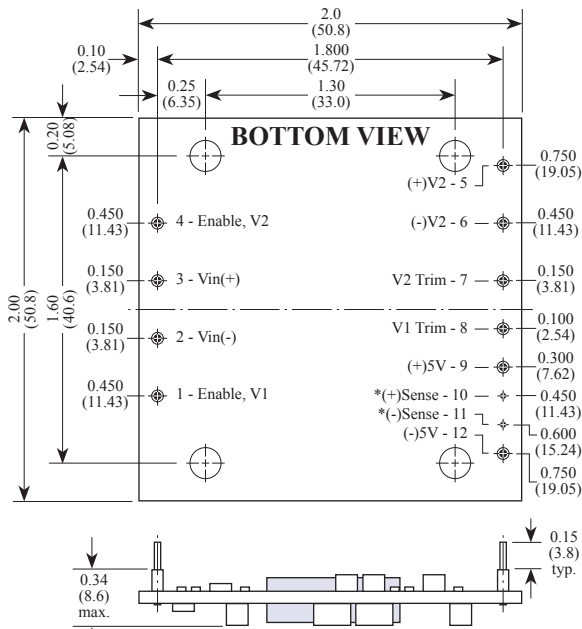

1. Sense pins are optional, must specify with suffix SP.
2. Sense pins 10, 11 are 0.020" (0.5mm) dia.
3. All other pins are 0.040" (1.0mm) dia. with 0.065" (1.65mm) standoff shoulders.

ENCAPSULATED (Optional, MC Suffix)

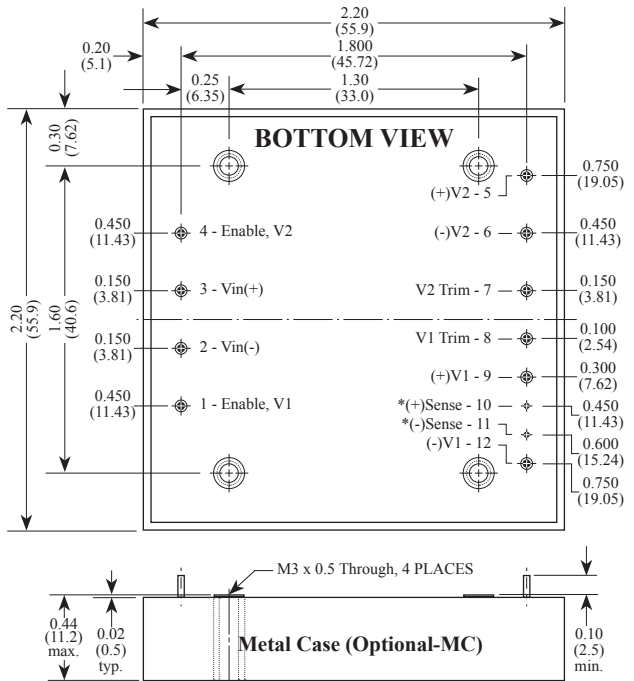

1. Sense pins are optional, must specify with suffix SP.
2. Sense pins 10, 11 are 0.020" (0.5mm) dia.
3. All other pins are 0.040" (1.0mm) dia.

INPUT			OUTPUT										Over Temp. Shutdown /Recover	EFF. (typ.)	MODEL NO.		
Nominal (Range)	UVLO		Power (Watt)	Voltage (V)			Current (A)			Ripple & Noise		Short Circuit Protection					
	On	Off		#	Set Point	Min.*	Max.*	#	Min.	Max.	Peak-Peak					R.M.S.	
24 (18-36)	17.8	17.5	30W	2.5V	V1	2.50	2.45	2.55	11	0	6.0	50mV	15mV	Hiccup Mode Indefinite	+105°C/ +95°C	88%	FH30D24025-12
				12V	V2	12.0	11.88	12.12	12	0.12	1.25	100mV	20mV				
			50W	2.5V	V1	2.50	2.45	2.55	11	0	10.0	50mV	15mV			88%	FH50D24025-12
				12V	V2	12.0	11.88	12.12	12	0.21	2.10	100mV	20mV				
			30W	2.5V	V1	2.50	2.45	2.55	11	0	6.0	50mV	15mV			88%	FH30D24025-15
				15V	V2	15.0	14.85	15.15	12	0.10	1.00	120mV	25mV				
			50W	2.5V	V1	2.50	2.45	2.55	11	0	10.0	50mV	15mV			88%	FH50D24025-15
				15V	V2	15.0	14.85	15.15	12	0.16	1.67	120mV	25mV				
			30W	3.3V	V1	3.30	3.20	3.40	11	0	5.0	50mV	15mV			88%	FH30D24033-12
				12V	V2	12.0	11.88	12.12	12	0.12	1.25	100mV	20mV				
			50W	3.3V	V1	3.30	3.20	3.40	11	0	8.0	50mV	15mV			88%	FH50D24033-12
				12V	V2	12.0	11.88	12.12	12	0.21	2.10	100mV	20mV				
	30W	3.3V	V1	5.00	4.90	5.10	11	0	5.0	50mV	15mV	88%	FH50D24033-15				
		15V	V2	15.0	14.85	15.15	12	0.10	1.00	120mV	25mV						
	50W	3.3V	V1	5.00	4.90	5.10	11	0	8.0	50mV	15mV	88%	FH50D24033-15				
		15V	V2	15.0	14.85	15.15	12	0.16	1.67	120mV	25mV						
	30W	5.0V	V1	5.00	4.90	5.10	11	0	3.0	75mV	15mV	88%	FH30D2405-12				
		12V	V2	12.0	11.88	12.12	12	0.12	1.25	100mV	20mV						
	50W	5.0V	V1	5.00	4.90	5.10	11	0	58.0	75mV	15mV	88%	FH50D2405-12				
		12V	V2	12.0	11.88	12.12	12	0.21	2.10	100mV	20mV						
	30W	5.0V	V1	5.00	4.90	5.10	11	0	3.0	75mV	15mV	88%	FH50D2405-15				
		15V	V2	15.0	14.85	15.15	12	0.10	1.00	120mV	25mV						
	50W	5.0V	V1	5.00	4.90	5.10	11	0	5.0	75mV	15mV	88%	FH50D2405-15				
		15V	V2	15.0	14.85	15.15	12	0.16	1.67	120mV	25mV						
48 (36-75)	34	33	30W	2.5V	V1	2.50	2.45	2.55	11	0	6.0	50mV	15mV	Hiccup Mode Indefinite	+105°C/ +95°C	88%	FH30D48025-12
				12V	V2	12.0	11.88	12.12	12	0.12	1.25	100mV	20mV				
			50W	2.5V	V1	2.50	2.45	2.55	11	0	10.0	50mV	15mV			88%	FH50D48025-12
				12V	V2	12.0	11.88	12.12	12	0.21	2.10	100mV	20mV				
			30W	2.5V	V1	2.50	2.45	2.55	11	0	6.0	50mV	15mV			88%	FH30D48025-15
				15V	V2	15.0	14.85	15.15	12	0.10	1.00	120mV	25mV				
			50W	2.5V	V1	2.50	2.45	2.55	11	0	10.0	50mV	15mV			88%	FH50D48025-15
				15V	V2	15.0	14.85	15.15	12	0.16	1.67	120mV	25mV				
			30W	3.3V	V1	3.30	3.20	3.40	11	0	5.0	50mV	15mV			88%	FH30D48033-12
				12V	V2	12.0	11.88	12.12	12	0.12	1.25	100mV	20mV				
			50W	3.3V	V1	3.30	3.20	3.40	11	0	8.0	50mV	15mV			88%	FH50D48033-12
				12V	V2	12.0	11.88	12.12	12	0.21	2.10	100mV	20mV				
	30W	3.3V	V1	5.00	4.90	5.10	11	0	5.0	50mV	15mV	88%	FH50D48033-15				
		15V	V2	15.0	14.85	15.15	12	0.10	1.00	120mV	25mV						
	50W	3.3V	V1	5.00	4.90	5.10	11	0	8.0	50mV	15mV	88%	FH50D48033-15				
		15V	V2	15.0	14.85	15.15	12	0.16	1.67	120mV	25mV						
	30W	5.0V	V1	5.00	4.90	5.10	11	0	3.0	75mV	15mV	88%	FH30D4805-12				
		12V	V2	12.0	11.88	12.12	12	0.12	1.25	100mV	20mV						
	50W	5.0V	V1	5.00	4.90	5.10	11	0	58.0	75mV	15mV	88%	FH50D4805-12				
		12V	V2	12.0	11.88	12.12	12	0.21	2.10	100mV	20mV						
	30W	5.0V	V1	5.00	4.90	5.10	11	0	3.0	75mV	15mV	88%	FH50D4805-15				
		15V	V2	15.0	14.85	15.15	12	0.10	1.00	120mV	25mV						
	50W	5.0V	V1	5.00	4.90	5.10	11	0	5.0	75mV	15mV	88%	FH50D4805-15				
		15V	V2	15.0	14.85	15.15	12	0.16	1.67	120mV	25mV						

* Combined Line & Load Regulation (Low Line to High Line & Min. Load to Full Load)

Continued on next Page

Product Numbering System & Selection Guide

FH	50	D	24	05	-	15	C
Series No.	Output Power	No Output	Input Voltage	V1		V2	Option
FH	30 : 30W 50 : 50W	D : Dual	24 : 18-36V 48 : 36-75V	025 : 2.5V 033 : 3.3V		12 : 12V 15 : 15V	C : Extended Temperature MC : Encapsulated

INPUT			OUTPUT										Over Temp. Shutdown /Recover	EFF. (typ.)	MODEL NO.		
Nominal (Range)	UVLO		Power (Watt)	Voltage (V)			Current (A)			Ripple & Noise		Short Circuit Protection					
	On	Off		#	Set Point	Min.*	Max.*	#	Min.	Max.	Peak-Peak					R.M.S.	
48W (18-75)	17.8	17.5	30W	2.5V	V1	2.50	2.45	2.55	11	0	6.0	50mV	15mV	Hiccup Mode Indefinite	+105°C/ +95°C	86%	FH30D48W025-12
				12V	V2	12.0	11.88	12.12	12	0.12	1.25	100mV	20mV				
			50W	2.5V	V1	2.50	2.45	2.55	11	0	10.0	50mV	15mV			86%	FH50D48W025-12
				12V	V2	12.0	11.88	12.12	12	0.21	2.10	100mV	20mV				
			30W	2.5V	V1	2.50	2.45	2.55	11	0	6.0	50mV	15mV			86%	FH30D48W025-15
				15V	V2	15.0	14.85	15.15	12	0.10	1.00	120mV	25mV				
			50W	2.5V	V1	2.50	2.45	2.55	11	0	10.0	50mV	15mV			86%	FH50D48W025-15
				15V	V2	15.0	14.85	15.15	12	0.16	1.67	120mV	25mV				
			30W	3.3V	V1	3.30	3.20	3.40	11	0	5.0	50mV	15mV			86%	FH30D48W033-12
				12V	V2	12.0	11.88	12.12	12	0.12	1.25	100mV	20mV				
			50W	3.3V	V1	3.30	3.20	3.40	11	0	8.0	50mV	15mV			86%	FH50D48W033-12
				12V	V2	12.0	11.88	12.12	12	0.21	2.10	100mV	20mV				
			30W	3.3V	V1	5.00	4.90	5.10	11	0	5.0	50mV	15mV			86%	FH50D48W033-15
				15V	V2	15.0	14.85	15.15	12	0.10	1.00	120mV	25mV				
			50W	3.3V	V1	5.00	4.90	5.10	11	0	8.0	50mV	15mV			86%	FH50D48W033-15
				15V	V2	15.0	14.85	15.15	12	0.16	1.67	120mV	25mV				
			30W	5.0V	V1	5.00	4.90	5.10	11	0	3.0	75mV	15mV			86%	FH30D48W05-12
				12V	V2	12.0	11.88	12.12	12	0.12	1.25	100mV	20mV				
			50W	5.0V	V1	5.00	4.90	5.10	11	0	58.0	75mV	15mV			86%	FH50D48W05-12
				12V	V2	12.0	11.88	12.12	12	0.21	2.10	100mV	20mV				
			30W	5.0V	V1	5.00	4.90	5.10	11	0	3.0	75mV	15mV			86%	FH50D48W05-15
				15V	V2	15.0	14.85	15.15	12	0.10	1.00	120mV	25mV				
			50W	5.0V	V1	5.00	4.90	5.10	11	0	5.0	75mV	15mV			86%	FH50D48W05-15
				15V	V2	15.0	14.85	15.15	12	0.16	1.67	120mV	25mV				

* Combined Line & Load Regulation (Low Line to High Line & Min. Load to Full Load)

NOTE :

BLOCK DIAGRAM

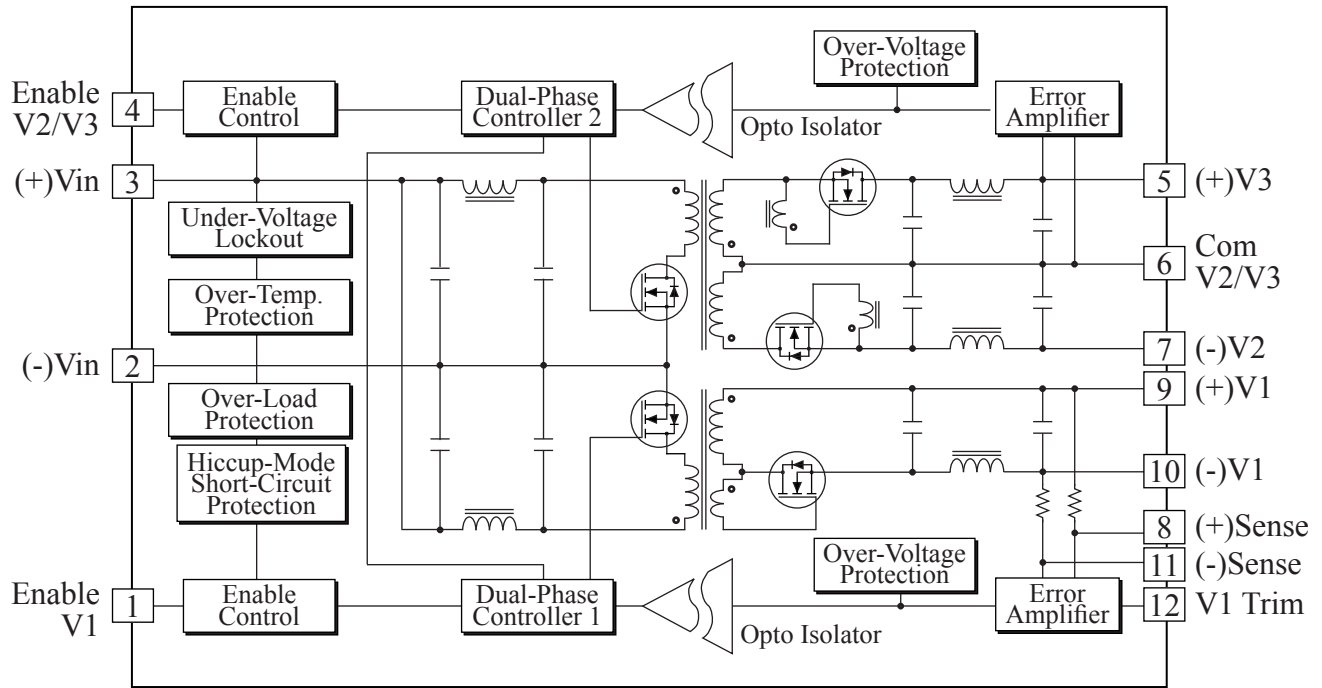

OPEN FRAME (Standard)

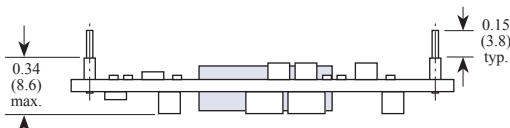
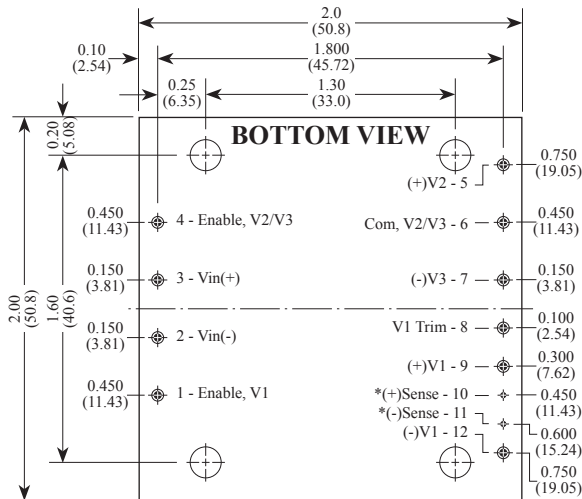

1. Sense pins are optional, must specify with suffix SP.
2. Sense pins 10, 11 are 0.020" (0.5mm) dia.
3. All other pins are 0.040" (1.0mm) dia. with 0.065" (1.65mm) standoff shoulders.

ENCAPSULATED (Optional, MC Suffix)

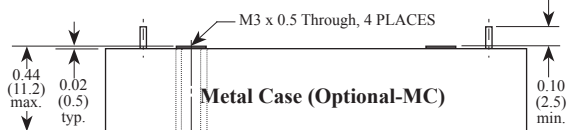
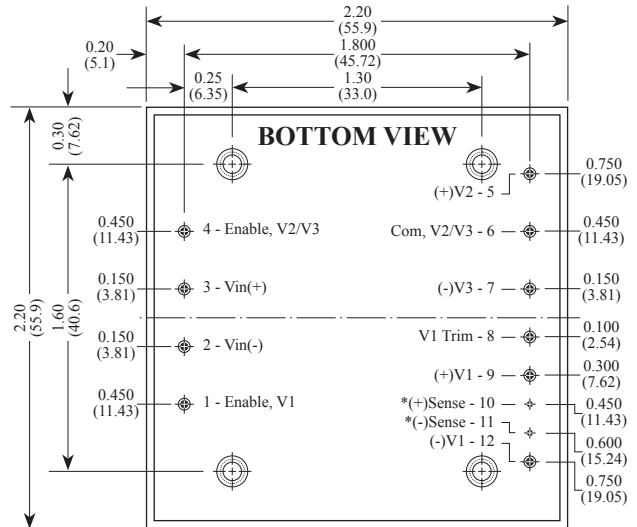

1. Sense pins are optional, must specify with suffix SP.
2. Sense pins 10, 11 are 0.020" (0.5mm) dia.
3. All other pins are 0.040" (1.0mm) dia.

INPUT		Power (watt)	OUTPUT									Short Circuit Protection	Over Temp. Shutdown /Recover	EFF. (typ.)	MODEL NO.	
Nominal (Range)	UVLO On/Off		Voltage (V)				Current (A)			Ripple & Noise						
			#	Set Point	Min.*	Max.*	#	Min.	Max.	Peak-Peak	R.M.S.					
24 (18 - 36)	17V/ 16V	30W	3.3V	V1	3.30	3.20	3.40	I1	0	5.0	50mV	10mV	Hiccup Mode Indefinite	+105°C/ +95°C	88%	FH30T24033-12
				+V3	+12.0	+11.88	+12.12	+I3	+0.1	+1.0	100mV	20mV				
				-V2	-12.0	-11.50	-12.50	-I2	-0.1	-0.5	100mV	20mV				
		50W	±12V	V1	3.30	3.20	3.40	I1	0	8.0	50mV	10mV			88%	FH50T24033-12
				+V3	+12.0	+11.88	+12.12	+I3	+0.2	+2.0	100mV	20mV				
				-V2	-12.0	-11.50	-12.50	-I2	-0.1	-1.0	100mV	20mV				
		30W	3.3V	V1	3.30	3.20	3.40	I1	0	5.0	50mV	10mV			88%	FH30T24033-12
				+V3	+15.00	+14.85	+15.15	+I3	+0.10	+1.0	120mV	25mV				
				-V2	-15.00	-14.40	-15.60	-I2	-0.10	-0.5	120mV	25mV				
		50W	±15V	V1	3.30	3.20	3.40	I1	0	8.0	50mV	10mV			88%	FH50T24033-15
				+V3	+15.00	+14.85	+15.15	+I3	+0.1	+1.5	150mV	25mV				
				-V2	-15.00	-14.40	-15.60	-I2	-0.1	-1.0	150mV	25mV				
		30W	5.0V	V1	5.00	4.90	5.10	I1	0	3.0	75mV	15mV			88%	FH30T2405-12
				+V3	+12.0	+11.88	+12.12	+I3	+0.1	+1.0	100mV	20mV				
				-V2	-12.0	-11.50	-12.50	-I2	-0.1	-0.5	100mV	20mV				
		50W	±12V	V1	5.00	4.90	5.10	I1	0	5.0	75mV	15mV			88%	FH50T2405-12
				+V3	+12.0	+11.88	+12.12	+I3	+0.2	+2.0	100mV	20mV				
				-V2	-12.0	-11.50	-12.50	-I2	-0.1	-1.0	100mV	20mV				
		30W	5.0V	V1	5.00	4.90	5.10	I1	0	3.0	75mV	15mV			88%	FH30T2405-15
				+V3	+15.00	+14.85	+15.15	+I3	+0.10	+1.0	120mV	25mV				
				-V2	-15.00	-14.40	-15.60	-I2	-0.10	-0.5	120mV	25mV				
		50W	±15V	V1	5.00	4.90	5.10	I1	0	5.0	75mV	15mV			88%	FH50T2405-15
				+V3	+15.00	+14.85	+15.15	+I3	+0.1	+1.5	150mV	25mV				
				-V2	-15.00	-14.40	-15.60	-I2	-0.1	-1.0	150mV	25mV				
30W	12V	V1	12.0	11.88	12.12	I1	0.12	1.25	100mV	20mV	88%	FH30T2412-05				
		+V3	+5.0	+4.90	+5.10	+I3	+0.2	+2.0	75mV	15mV						
		-V2	-5.0	-4.80	-5.20	-I2	-0.1	-1.0	75mV	15mV						
50W	±5.0V	V1	12.0	11.88	12.12	I1	0.12	1.25	100mV	20mV	88%	FH50T2412-05				
		+V3	+5.0	+4.90	+5.10	+I3	+0.2	+4.0	75mV	15mV						
		-V2	-5.0	-4.80	-5.20	-I2	-0.1	-2.0	75mV	15mV						
30W	15V	V1	12.0	11.88	12.12	I1	0.12	1.25	100mV	20mV	88%	FH30T2415-05				
		+V3	+5.0	+4.90	+5.10	+I3	+0.2	+2.0	75mV	15mV						
		-V2	-5.0	-4.80	-5.20	-I2	-0.1	-1.0	75mV	15mV						
50W	±5.0V	V1	12.0	11.88	12.12	I1	0.12	1.25	100mV	20mV	88%	FH50T2415-05				
		+V3	+5.0	+4.90	+5.10	+I3	+0.2	+4.0	75mV	15mV						
		-V2	-5.0	-4.80	-5.20	-I2	-0.1	-2.0	75mV	15mV						
48 (36-75)	34V/ 33V	30W	3.3V	V1	3.30	3.20	3.40	I1	0	5.0	50mV	10mV	Hiccup Mode Indefinite	+105°C/ +95°C	88%	FH30T48033-12
				+V3	+12.0	+11.88	+12.12	+I3	+0.1	+1.0	100mV	20mV				
				-V2	-12.0	-11.50	-12.50	-I2	-0.1	-0.5	100mV	20mV				
		50W	±12V	V1	3.30	3.20	3.40	I1	0	8.0	50mV	10mV			88%	FH50T48033-12
				+V3	+12.0	+11.88	+12.12	+I3	+0.2	+2.0	100mV	20mV				
				-V2	-12.0	-11.50	-12.50	-I2	-0.1	-1.0	100mV	20mV				
		30W	3.3V	V1	3.30	3.20	3.40	I1	0	5.0	50mV	10mV			88%	FH30T48033-12
				+V3	+15.00	+14.85	+15.15	+I3	+0.10	+1.0	120mV	25mV				
				-V2	-15.00	-14.40	-15.60	-I2	-0.10	-0.5	120mV	25mV				
		50W	±15V	V1	3.30	3.20	3.40	I1	0	8.0	50mV	10mV			88%	FH50T48033-15
				+V3	+15.00	+14.85	+15.15	+I3	+0.1	+1.5	150mV	25mV				
				-V2	-15.00	-14.40	-15.60	-I2	-0.1	-1.0	150mV	25mV				
		30W	5.0V	V1	5.00	4.90	5.10	I1	0	3.0	75mV	15mV			88%	FH30T4805-12
				+V3	+12.0	+11.88	+12.12	+I3	+0.1	+1.0	100mV	20mV				
				-V2	-12.0	-11.50	-12.50	-I2	-0.1	-0.5	100mV	20mV				
		50W	±12V	V1	5.00	4.90	5.10	I1	0	5.0	75mV	15mV			88%	FH50T4805-12
				+V3	+12.0	+11.88	+12.12	+I3	+0.2	+2.0	100mV	20mV				
				-V2	-12.0	-11.50	-12.50	-I2	-0.1	-1.0	100mV	20mV				
		30W	5.0V	V1	5.00	4.90	5.10	I1	0	3.0	75mV	15mV			88%	FH30T4805-15
				+V3	+15.00	+14.85	+15.15	+I3	+0.10	+1.0	120mV	25mV				
				-V2	-15.00	-14.40	-15.60	-I2	-0.10	-0.5	120mV	25mV				
		50W	±15V	V1	5.00	4.90	5.10	I1	0	5.0	75mV	15mV			88%	FH50T4805-15
				+V3	+15.00	+14.85	+15.15	+I3	+0.1	+1.5	150mV	25mV				
				-V2	-15.00	-14.40	-15.60	-I2	-0.1	-1.0	150mV	25mV				
30W	12V	V1	12.0	11.88	12.12	I1	0.12	1.25	100mV	20mV	88%	FH30T4812-05				
		+V3	+5.0	+4.90	+5.10	+I3	+0.2	+2.0	75mV	15mV						
		-V2	-5.0	-4.80	-5.20	-I2	-0.1	-1.0	75mV	15mV						
50W	±5.0V	V1	12.0	11.88	12.12	I1	0.12	1.25	100mV	20mV	88%	FH50T4812-05				
		+V3	+5.0	+4.90	+5.10	+I3	+0.2	+4.0	75mV	15mV						
		-V2	-5.0	-4.80	-5.20	-I2	-0.1	-2.0	75mV	15mV						
30W	15V	V1	12.0	11.88	12.12	I1	0.12	1.25	100mV	20mV	88%	FH30T4815-05				
		+V3	+5.0	+4.90	+5.10	+I3	+0.2	+2.0	75mV	15mV						
		-V2	-5.0	-4.80	-5.20	-I2	-0.1	-1.0	75mV	15mV						
50W	±5.0V	V1	12.0	11.88	12.12	I1	0.12	1.25	100mV	20mV	88%	FH50T4815-05				
		+V3	+5.0	+4.90	+5.10	+I3	+0.2	+4.0	75mV	15mV						
		-V2	-5.0	-4.80	-5.20	-I2	-0.1	-2.0	75mV	15mV						

* Combined Line & Load (Low Line to High Line, Min. Load to Full Load)

Continued on Next Page

INPUT		OUTPUT										Over Temp. Shutdown /Recover	EFF. (typ.)	MODEL NO.		
Nominal (Range)	UVLO On/Off	Power (watt)	Voltage (V)				Current (A)			Ripple & Noise					Short Circuit Protection	
			#	Set Point	Min.*	Max.*	#	Min.	Max.	Peak-Peak	R.M.S.					
48 (36-75)	34V/ 33V	30W	3.3V	V1	3.30	3.20	3.40	11	0	5.0	50mV	10mV	Hiccup Mode Indefinite	+105°C/ +95°C	86%	FH30T48W033-12
				+V3	+12.0	+11.88	+12.12	+13	+0.1	+1.0	100mV	20mV				
				-V2	-12.0	-11.50	-12.50	-12	-0.1	-0.5	100mV	20mV				
			±12V	V1	3.30	3.20	3.40	11	0	8.0	50mV	10mV				
				+V3	+12.0	+11.88	+12.12	+13	+0.2	+2.0	100mV	20mV				
				-V2	-12.0	-11.50	-12.50	-12	-0.1	-1.0	100mV	20mV				
		50W	3.3V	V1	3.30	3.20	3.40	11	0	5.0	50mV	10mV				
				+V3	+12.0	+11.88	+12.12	+13	+0.10	+1.0	120mV	25mV				
				-V2	-12.0	-11.50	-12.50	-12	-0.10	-0.5	120mV	25mV				
			±15V	V1	3.30	3.20	3.40	11	0	8.0	50mV	10mV				
				+V3	+12.0	+11.88	+12.12	+13	+0.1	+1.5	150mV	25mV				
				-V2	-12.0	-11.50	-12.50	-12	-0.1	-1.0	150mV	25mV				
		30W	5.0V	V1	5.00	4.90	5.10	11	0	3.0	75mV	15mV				
				+V3	+12.0	+11.88	+12.12	+13	+0.1	+1.0	100mV	20mV				
				-V2	-12.0	-11.50	-12.50	-12	-0.1	-0.5	100mV	20mV				
			±12V	V1	5.00	4.90	5.10	11	0	5.0	75mV	15mV				
				+V3	+12.0	+11.88	+12.12	+13	+0.2	+2.0	100mV	20mV				
				-V2	-12.0	-11.50	-12.50	-12	-0.1	-1.0	100mV	20mV				
		50W	5.0V	V1	5.00	4.90	5.10	11	0	3.0	75mV	15mV				
				+V3	+12.0	+11.88	+12.12	+13	+0.10	+1.0	120mV	25mV				
				-V2	-12.0	-11.50	-12.50	-12	-0.10	-0.5	120mV	25mV				
			±15V	V1	5.00	4.90	5.10	11	0	5.0	75mV	15mV				
				+V3	+12.0	+11.88	+12.12	+13	+0.1	+1.5	150mV	25mV				
				-V2	-12.0	-11.50	-12.50	-12	-0.1	-1.0	150mV	25mV				
		30W	12V	V1	12.0	11.88	12.12	11	0.12	1.25	100mV	20mV				
				+V3	+5.0	+4.90	+5.10	+13	+0.2	+2.0	75mV	15mV				
				-V2	-5.0	-4.80	-5.20	-12	-0.1	-1.0	75mV	15mV				
			±5.0V	V1	12.0	11.88	12.12	11	0.12	1.25	100mV	20mV				
				+V3	+5.0	+4.90	+5.10	+13	+0.2	+4.0	75mV	15mV				
				-V2	-5.0	-4.80	-5.20	-12	-0.1	-2.0	75mV	15mV				
		50W	12V	V1	12.0	11.88	12.12	11	0.12	1.25	100mV	20mV				
				+V3	+5.0	+4.90	+5.10	+13	+0.2	+2.0	75mV	15mV				
				-V2	-5.0	-4.80	-5.20	-12	-0.1	-1.0	75mV	15mV				
			±5.0V	V1	12.0	11.88	12.12	11	0.12	1.25	100mV	20mV				
				+V3	+5.0	+4.90	+5.10	+13	+0.2	+2.0	75mV	15mV				
				-V2	-5.0	-4.80	-5.20	-12	-0.1	-1.0	75mV	15mV				
		30W	15V	V1	12.0	11.88	12.12	11	0.12	1.25	100mV	20mV				
				+V3	+5.0	+4.90	+5.10	+13	+0.2	+2.0	75mV	15mV				
				-V2	-5.0	-4.80	-5.20	-12	-0.1	-1.0	75mV	15mV				
			±5.0V	V1	12.0	11.88	12.12	11	0.12	1.25	100mV	20mV				
				+V3	+5.0	+4.90	+5.10	+13	+0.2	+4.0	75mV	15mV				
				-V2	-5.0	-4.80	-5.20	-12	-0.1	-2.0	75mV	15mV				

* Combined Line & Load (Low Line to High Line, Min. Load to Full Load)

Product Numbering System

FH	30	T	24	033 -	12	MC
Series No.	Output Power	No Output	Input Voltage	V1 Output	V2/V3 Outputs	Options
FH	30 : 30W 50 : 50W	T : Triple	24 : 18-36V 48 : 36-75V 48W : 20-75V	033 : 3.3V 05 : 5.0V	12 : ±12V 15 : ±15V	C : Extended Temp. SP : Sense Pins MC : Encapsulated

NOTE :

BLOCK DIAGRAM

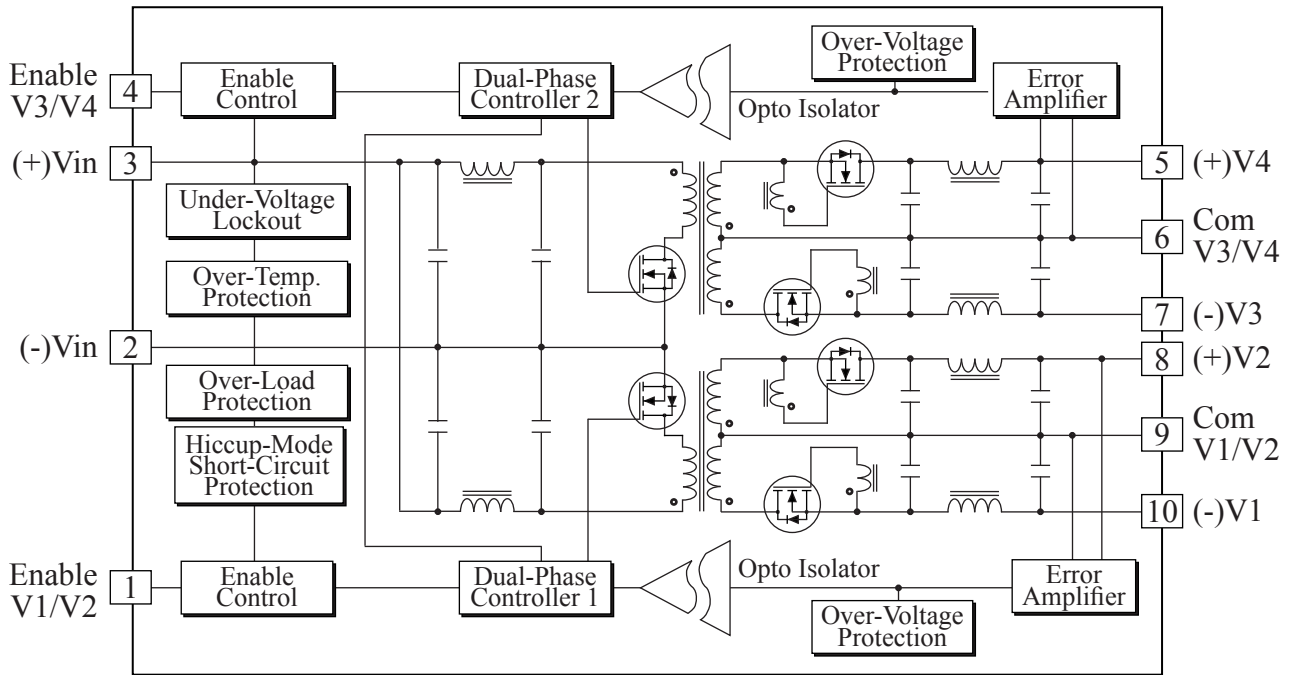

OPEN FRAME (Standard)

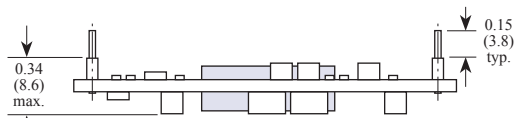
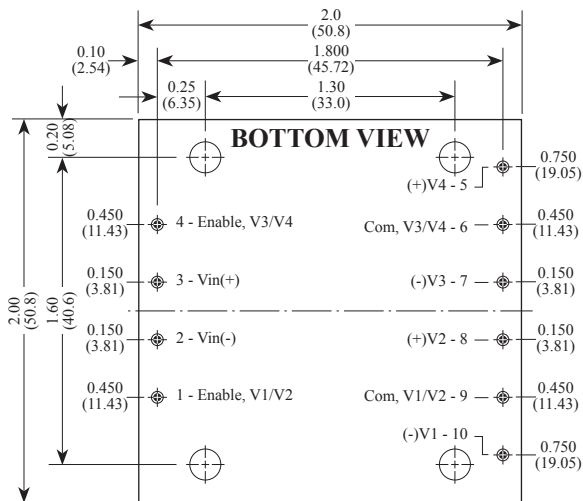

1. Sense pins are optional, must specify with suffix SP.
2. Sense pins 10, 11 are 0.020" (0.5mm) dia.
3. All other pins are 0.040" (1.0mm) dia. with 0.065" (1.65mm) standoff shoulders.

ENCAPSULATED (Optional, MC Suffix)

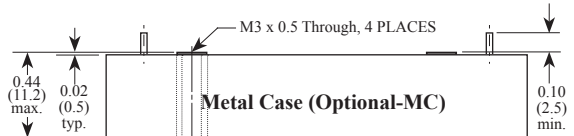
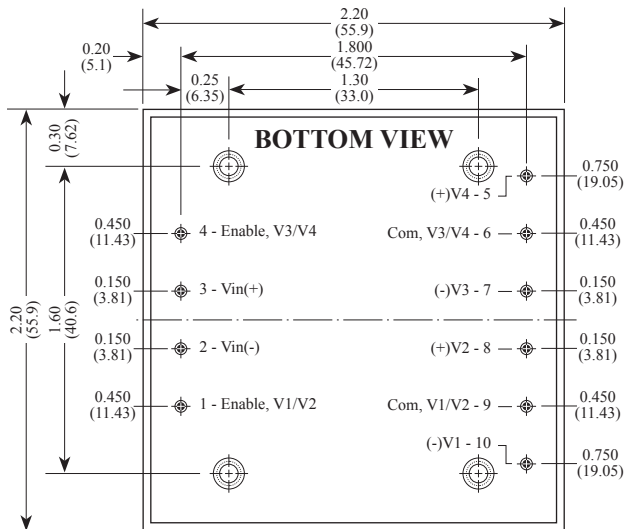

1. Sense pins are optional, must specify with suffix SP.
2. Sense pins 10, 11 are 0.020" (0.5mm) dia.
3. All other pins are 0.040" (1.0mm) dia.

INPUT		OUTPUT										Short Circuit Protection	Over Temp. Shutdown /Recover	Max. Output Power	EFF. (typ.)	MODEL NO.		
Nominal (Range)	UVLO On/Off	Voltage (V)*				Current (A)			Ripple & Noise									
		#	Set Point	Min.*	Max.*	#	Min.	Max.	Peak-Peak	R.M.S.								
24 (18-36)	17V /16V	±5.0V ±12V	+V2	+5.00	+4.90	+5.10	+I2	+0.2	+4.0	75mV	15mV	Hiccup Mode Indefinite	+105°C/ +95°C	50W	88%	FH50Q2405-12		
			-V1	-5.00	-4.80	-5.20	-I1	-0.1	-2.0	75mV	15mV							
			+V4	+12.00	+11.88	+12.12	+I4	+0.20	+2.0	100mV	20mV							
		-V3	-12.00	-11.50	-12.50	-I3	-0.10	-1.0	100mV	20mV								
		+V2	+5.00	+4.90	+5.10	+I2	+0.25	+2.5	75mV	15mV								
		-V3	-15.00	-14.40	-15.60	-I3	-0.1	-1.0	120mV	25mV								
48 (36 - 75)	34V /33V	±5.0V ±12V	+V2	+5.00	+4.90	+5.10	+I2	+0.2	+4.0	75mV	15mV			Hiccup Mode Indefinite	+105°C/ +95°C	50W	88%	FH50Q4805-12
			-V1	-5.00	-4.80	-5.20	-I1	-0.1	-2.0	75mV	15mV							
			+V4	+12.00	+11.88	+12.12	+I4	+0.20	+2.0	100mV	20mV							
		-V3	-12.00	-11.50	-12.50	-I3	-0.10	-1.0	100mV	20mV								
		+V2	+5.00	+4.90	+5.10	+I2	+0.25	+2.5	75mV	15mV								
		-V3	-15.00	-14.40	-15.60	-I3	-0.1	-1.0	120mV	25mV								
48W (20 - 75)	17V /16V	±5.0V ±12V	+V2	+5.00	+4.90	+5.10	+I2	+0.2	+4.0	75mV	15mV	Hiccup Mode Indefinite	+105°C/ +95°C			50W	86%	FH50Q48W05-12
			-V1	-5.00	-4.80	-5.20	-I1	-0.1	-2.0	75mV	15mV							
			+V4	+12.00	+11.88	+12.12	+I4	+0.20	+2.0	100mV	20mV							
		-V3	-12.00	-11.50	-12.50	-I3	-0.10	-1.0	100mV	20mV								
		+V2	+5.00	+4.90	+5.10	+I2	+0.25	+2.5	75mV	15mV								
		-V3	-15.00	-14.40	-15.60	-I3	-0.1	-1.0	120mV	25mV								
48W (20 - 75)	17V /16V	±5.0V ±15V	+V4	+15.00	+14.85	+15.15	+I4	+0.15	+1.5	120mV	25mV			Hiccup Mode Indefinite	+105°C/ +95°C	50W	86%	FH50Q48W05-15
			-V3	-15.00	-14.40	-15.60	-I3	-0.1	-1.0	120mV	25mV							

¹⁾ Measured from 10% to max. load.

²⁾ Ripple noise measured with X1 probe tip & ground ring.

Product Numbering System & Selection Guide

FH	50	Q	24	012 -	05	C
Series No.	Output Power*	No Output	Input Voltage	+V2/-V1 Output	+V4/-V3 Output	Options
FH	50 : 50W	Q : Quad	24 : 18-36V	015 : 1.2V	05 : ±5.0V	C : Extended Temperature
			48 : 36-75V	025 : 2.5V	12 : ±12V	MC : Encapsulated
			48W : 20-75V	12 : 12V	15 : ±15V	