

DC to AC Power inverter manual

HT-301SA1



MODEL: HT-S-150

- ⊙ Pure sine wave output (<2% THD).
- ⊙ Input & Output fully isolation design.
- ⊙ High Efficiency 87% ~ 90%.
- ⊙ High surge in motor start capacity.
- ⊙ 5-stage thermal control fan.
- ⊙ Frequency 50/60HZ switchable.
- ⊙ Auto restart.
- ⊙ Small size.

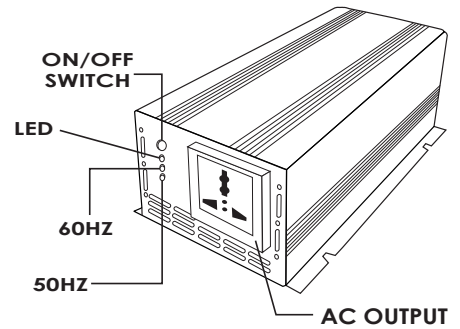

Rear view

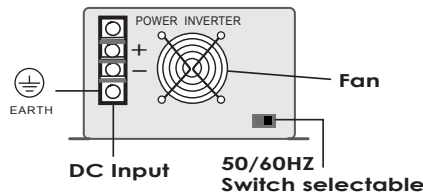

Firstly, thank you for purchase our product. Please read this manual carefully before installing or using this product.

SPECIFICATIONS

Model No.	HT-S-150-12	HT-S-150-24	HT-S-150-48
Continuous Output Power	150W		
Max Output Power	300W		
DC Input Voltage	DC12V	DC24V	DC48V
AC Output Voltage	100VAC / 110VAC 120VAC / 220VAC 230VAC / 240VAC		
Frequency	50Hz / 60Hz±3Hz (Switch selectable)		
Efficiency	>87%		
No Load current Draw	<0.7A	<0.4A	<0.2A
Output Wave form	Sine Wave 		
Distortion	<2%		
Temperature Protection:	(55°C±5°C)		
Input Low Voltage Protection	YES		
Input Low Voltage Alarm	YES		
Input Reverse Polarity circuit protection	YES		
Output Short Circuit Protection	YES		
Overload Protection	YES		
Dimensions (L x W x H / mm)	250 x 120 x 72		
Net Weight (by Kg/s)	1.9Kgs		
Gross Weight (by Kg/s) ..with cable	2.8		

Introduction

This model is used in a wide range of application including remote homes, RVs, sailboats and powerboats. It will operate most televisions and VTRs, personal computers, small appliances and tools such as drills, sanders, grinders, mixers and blenders. To get the most out of the power inverter, it must be installed and used properly. Please read the instructions in this manual before installing and using this model.

Quick hook - up and testing

If you would like to quick hook-up the power inverter and check its performance before going ahead with your installation, please follow these guidelines:

1. Unpack and inspect the power inverter, check to see that the power switch is in the OFF position.
2. Connect the cables to the power input terminals on the rear panel of power inverter. The red terminal is positive (+) and black terminal is negative (-). Connect the cables into the terminals and tighten the wing nut to clamp the wires securely.
3. Connect the cable from the negative terminal of the inverter to the negative terminal of the power source. Make a secure connection.

⚠ Loosely tightened connectors result in excessive drop and may cause overheated wires and melted insulation.

4. Before proceed further, carefully check that cable you have just connected connects from the negative terminal of inverter to the negative output terminal of the power source.

⚠ Reverse polarity connection will blow a fuse in inverter and may permanently damage the inverter. Damage caused by reverse polarity connection is not covered by our warranty.

5. Connect the cable from the positive terminal of inverter to the positive terminal of the power source. Make secure connection.

⚠ You may observe a spark when you make this connection since current may flow to charge capacitors in the power inverter. Do not make this connection in the presence of flammable fumes, explosions or fire may result.

6. Set the power switch to the ON position. Check the meters and indicators on the front panel of the inverter.

If does not, check your power source and the connections to inverter. The other indicators should be off.

7. Set power inverter switch to the OFF position, the indicator lights may blink. Plug the test load into the AC receptacle on the front panel of the inverter. Please keep switch in off position.
8. Set power inverter switch to the ON position, the inverter should supply power to the load.

Installation

1. Where to install
The power inverter should be installed in a location that meets the following requirements:
 - a. Dry ☹ Do not allow water to drip or splash on the inverter.
 - b. Cool ☹ Ambient air temperature should be between 0°C and 40°C, the cooler the better.
 - c. Ventilated ☹ Allow at least one inch of clearance around the inverter for airflow. Ensure the ventilation openings on the rear and bottom of the unit are not obstructed.
 - d. Safe ☹ Do not install the inverter in the same compartment as batteries or in any compartment capable of storing flammable liquids such as gasoline.

2. Cables
DC to AC inverters require high amperage/low voltage DC power to low amperage/high voltage AC power. To operate properly connect inverter DC input terminals direct to battery with heaviest wire available see chart below:

Max Watts Out	Approx. Amps	Req'd Wire Gauge
100W	10A	#18
150W	15A	#14
200W	20A	#12
300W	30A	#10
400W	40A	#8
600W	54A	#6 or 2x#10

3. Grounding

The power inverter has a lug on the rear panel to chassis ground. This is to connect the chassis of the power inverter to the ground. The ground terminals in the AC outlets on the front panel of the inverter are also connected to the ground lug. The chassis ground lug must be connected to a grounding point, which will vary depending on where the power inverter is installed. In a vehicle, connect the chassis ground to the chassis of the vehicle.

In a boat, connect to the boat's grounding systems. In a fixed location, connect the chassis ground lug to earth.

The neutral (common) conductor of the power inverter AC output circuit is connected to the chassis ground.

Therefore, when the chassis is connected to ground, the neutral conductor will also be grounded. This conforms to national electrical code requirements that separately derived AC sources (such as inverters and generators) have their neutral tied to ground in the same way that the neutral conductor from the utility line is tied to ground at AC breaker panel.



The negative DC input of the power inverter is connected to the capacitance, then to the ground a positive ground DC system. A positive ground DC system has the positive terminal of the battery connected to the chassis of the vehicle or to the grounding point.

Warning!

Do not operate the power inverter without connecting it to ground. Electrical shock hazard may result.

Operation

To operate the power inverter, turn it on using the ON/OFF switch on the front panel. The power inverter is now ready to deliver AC power to your loads. If you are operating several loads from the power inverter, turn them on separately after the inverter has been turned on. This will ensure that the power inverter does not have to deliver the starting currents for all the loads at once.

Controls and indicators

The ON/OFF switch turns the control circuit in the power inverter on and off. It does not disconnect power from the power inverter.

Operating limits

1. Overload / Auto re-start

The inverter would operate most AC loads within its power rating. If the load is over the specification, HT-S-300X will auto re-start 5 times, if not success, the inverter will shut down automatically.

2. Overtemp

The buzz will be noisy if the temperature is too high, then the inverter will be shut down automatically. Please re-set it after the inverter got cooling.

Note 1: The speed of fan operation will change 5-stage to follow the inverter internal temperature.

3. Input voltage

The power inverter will operate from input voltage range 10V-15 (12V) or 20V-30V (24V). If the voltage drops too low (※1) or raise too high (※2), the inverter will shut down automatically. Before shut down, buzz noise will warn you.

※1: <10.3V(12V spec) or <20.6V(24V spec)

※2: <15V(12V spec) or <30V(24V spec)

4. Frequency Switchable

Adjust 50/60 HZ through the switchable button. Buzz noise will remind you:
buzz1-50HZ
buzz2-60HZ

Please turn on the inverter again when you change frequency.

Troubleshooting

Television interference :

Operation of the power inverter can interfere with television reception on some channels. If this situation occurs, the following steps may help to alleviate the problem.

-Make sure that the chassis ground lug on the back of the power inverter is solidly connected to the ground system of your vehicle, boat or home.

-Do not operate high power loads with the power inverter while watching television.

-Make sure that the antenna feeding your television provides an adequate (snow free) signal and that you are using good quality cable between the antenna and the television.

-Move the television as far away from the power inverter as possible.

-Keep the cables between the battery and the power inverter as short as possible and twist them together with about 2 to 3 twists per foot. This minimizes radiated interference from the cables.

Maintenance

Very little maintenance is required to keep your inverter operating properly.

You should clean the exterior of the unit periodically with a damp cloth to prevent accumulation of dust and dirt. At the same time, tighten the screws on the DC input terminals.

Troubleshooting guide

Problem	possible cause	solution
HIGH BATT SHUTDOWN	Battery voltage too high	Check for fault with battery charging system. Manually reset inverter by turning switch to 'On' again.
LOW BATT BUZZ, SHUTDOWN	Battery voltage too low	Charge battery. Manually reset inverter by turning switch to 'On' again.
OVERLOAD SHUTDOWN	Battery current too high, probable AC overload	Reduce load on the inverter.
OVERTEMP BUZZ, SHUTDOWN	System over-temperature	Improve ventilation and cooling and / or reduce load on the inverter.
SYSTEM SHUTDOWN	Overload or system hardware fault	Ensure all loads and disconnected. Try to reset the unit by switching to 'On' if unit still does not operate, contact your distributor/ merchant/ retailer for service/ warranty replacement.