

**Input Ranges :**  
**9-75 VDC**

**Output Output:**  
**Single Output**  
**3.3V - 24V**  
**Bipolar Output**  
**±5.0V, ±12V, ±15V**  
**Dual Output**  
**+5.0V, +12V,**  
**+5.0V, +24V**  
**Triple Output**  
**+5.0V / ±12V,**  
**+5.0V / ±15V**

**Output Power:**  
**25 - 30 W**



**FEATURES**

**General:**

- PC Mount & Chassis Mount
- Output Power to 30 Watts
- Wide Input Range : 9-75Vdc
- 2:1 & 4:1 Input Voltage Range
- High Conversion Efficiency to 84%
- Line & Load Regulation to ±1.0%
- Fixed Operating Frequency
- Output Over-Load Protection
- Output Over-Voltage Protection
- Output Trim or Sense Functions
- Remote On/Off Control

**Isolation:**

- Isolation Voltage > 500V

**APPLICATIONS**

- Distributed Power Systems
- Workstations
- Computer Equipment
- Communications Equipment

ACON's M series DC-DC converter are designed for telecommunications, industrial and instrument applications. The wide input range (2:1 & 4:1) is ideal for battery or unregulated input applications. These converters features current-mode with MOSFET switching at 200 KHz. Automatic feed-forward compensation, pulse-by-pulse current limiting and output short-circuit protection are standard for all models. Input is well filtered to reduce reflected ripple current and efficiency is constant virtually independent of line variation. Optional heatsink is available. Mounting inserts are provided for chassis and/or heatsink mounting. All models are encapsulated in a 3.0" x 3.0" x 0.52" metal case with six-sided emi/rfi shielding.

**TABLE OF CONTANTS :**

General Specifications .....	2
Single Output .....	4
Bipolar Output .....	6
Dual Output .....	8
Triple Output.....	10

**1. Absolute Maximum Ratings**

Stresses in excess of the absolute maximum ratings can cause performance degradation, adversely effect longterm reliability, and cause permanent damage to the device.

Parameter	Conditions / Description	Min	Max	Units
<b>Input Voltage</b>				
Continuous	12	-0.3	20	Vdc
	24	-0.3	38	Vdc
	48	-0.3	78	Vdc
	W24	-0.3	38	Vdc
	W48	-0.3	78	Vdc
Transient (100mSec.)	12	-0.3	22	Vdc
	24	-0.3	40	Vdc
	48	-0.3	80	Vdc
	W-24	-0.3	40	Vdc
	W-48	-0.3	80	Vdc
<b>Operating Temperature</b>	All models, base plate temperature	-40	+95	°C
<b>Storage Temperature</b>	<b>Ambient</b>	-55	+105	°C
<b>Isolation Voltage</b>	Input to Output		+700	Vdc

**2. Input Specifications**

Parameter	Conditions / Description	Min	Nom	Max	Units
<b>Input Voltage</b>					
Voltage Range (Continuous)	12	9	12	18	Vdc
	24	18	24	36	Vdc
	48	36	48	75	Vdc
	W-24	10	24	36	Vdc
	W-48	18	48	75	Vdc

**3. Enable (On-Off Control)**

Parameter	Conditions / Description	Min	Nom	Max	Units
<b>Enable Pin</b>					
Open Circuit Voltage			5		Vdc
Source Current				1	mA
<b>Positive Logic</b>	<b>Standard</b>				
On-Control	Logic High or Floating	5.0		18	Vdc
Off-Control		-0.5		1.8	Vdc
<b>Negative Logic</b>	<b>Not Available</b>				

\* Enable pin can be left floating if not used.

**4. Output Specifications**

Parameter	Conditions / Description	Min	Nom	Max	Units
Voltage Accuracy	Please see table				%
Output Current	Please see table				Adc
Output Trim	Not Available				%Vout
Over Voltage Protection	Not available				Vdc
Line Regulation				±1.0	%Vout
Load Regulation				±1.0	%Vout
Transient Respoonse	50% ± 25% step load change		400		µSec.
Ripple & Noise	Please see table				mVp-p
Switching Frequency			200		KHz

**5. Output Trim**

Parameter	Conditions / Description	Min	Nom	Max	Units
<b>Negative Trim</b>	Standard				
Trim Up	Trim Pin to (-)Vout			10	%Vdc
Trim Down	Trim Pin to (+)Vout	10			%Vdc
<b>Positive Trim</b>	Not Available				

\* Trim pin can be left floating if not used

**6. Environmental and Mechanical Specifications**

Parameter	Conditions / Description	Min	Nom	Max	Units
Operating Temperature	PCB Temperature	-40		+95	°C
Storage Temperature		-55		+105	°C
Temperature Coefficient				±0.02	%/°C
Shock	Halfsine wave, 3 axes	50			g
Sinusoidal Vibration	GR-63-CORE, Section 5.4.2	1			g
Humidity	Relative Humidity, Non-Condensing			95	%R.H.
Weight			1.0 (28)		Oz (g)
MTBF (calculated)	Bellcore TR-NWT-000332 method 1 - parts count	0.5			MHrs

**7. Isolation Specifications**

Parameter	Conditions / Description	Min	Nom	Max	Units
Isolation Voltage					
Input to Output		500			Vdc
I/O to Case		500			Vdc
Isolation Resistance	Input to Output	10			MΩ
Isolation Capacitance	Input to Output		3		nF

INPUT		OUTPUT								EFF. (typ.)	MODEL NO.
Nominal (Range)	Max. Output Power	Voltage (V)			Current (A)		Ripple & Noise		Over Load Protection		
		Set Point	Min.*	Max.*	Min.	Max.	Peak-Peak	R.M.S.			
12 (9-18)	25W	5.00	4.90	5.10	0.5	5.0	75mV	15mV	Pulse by Pulse Current Limiting	80%	M25S1205
	30W	12.0	11.88	12.12	0.25	2.5	100mV	25mV		82%	M30S1212
	30W	15.0	14.85	15.15	0.2	2.0	120mV	30mV		82%	M30S1215
	30W	24.0	23.76	24.24	0.12	1.25	200mV	40mV		82%	M30S1224
24 (18-36)	25W	5.00	4.90	5.10	0.5	5.0	75mV	15mV		82%	M25S2405
	30W	12.0	11.88	12.12	0.25	2.5	100mV	25mV		84%	M30S2412
	30W	15.0	14.85	15.15	0.2	2.0	120mV	30mV		84%	M30S2415
	30W	24.0	23.76	24.24	0.12	1.25	200mV	40mV		84%	M30S2424
48 (36-75)	25W	5.00	4.90	5.10	0.5	5.0	75mV	15mV		82%	M25S4805
	30W	12.0	11.88	12.12	0.25	2.5	100mV	25mV		84%	M30S4812
	30W	15.0	14.85	15.15	0.2	2.0	120mV	30mV		84%	M30S4815
	30W	24.0	23.76	24.24	0.12	1.25	200mV	40mV		84%	M30S4824
W-24 (10-36)	25W	5.00	4.90	5.10	0.5	5.0	75mV	15mV		80%	MW25S2405
	30W	12.0	11.88	12.12	0.25	2.5	100mV	25mV		82%	MW30S2412
	30W	15.0	14.85	15.15	0.2	2.0	120mV	30mV		82%	MW30S2415
	30W	24.0	23.76	24.24	0.12	1.25	200mV	40mV		82%	MW30S2424
W-48 (20-75)	25W	5.00	4.90	5.10	0.5	5.0	75mV	15mV	80%	MW25S4805	
	30W	12.0	11.88	12.12	0.25	2.5	100mV	25mV	82%	MW30S4812	
	30W	15.0	14.85	15.15	0.2	2.0	120mV	30mV	82%	MW30S4815	
	30W	24.0	23.76	24.24	0.12	1.25	200mV	40mV	82%	MW30S4824	

\* Combined Line & Load Regulation.

**Product Numbering System & Selection Guide**

<b>M</b>	<b>25</b>	<b>S</b>	<b>24</b>	<b>05</b>	<b>TS</b>
Series No.	Output Power	No Output	Input Voltage	Output Voltage	Options
<b>M</b>	25 : 25W 30 : 30W	S : Single	12 : 9-18V 24 : 18-36V 48 : 36-75V	03 : 3.3V 05 : 5.0V 12 : 12V	TS : Terminal Strips
<b>MW</b>			24 : 10-36V	15 : 15V	
<b>MW</b>			48 : 18-75V	24 : 24V	

**PC Board Mount**

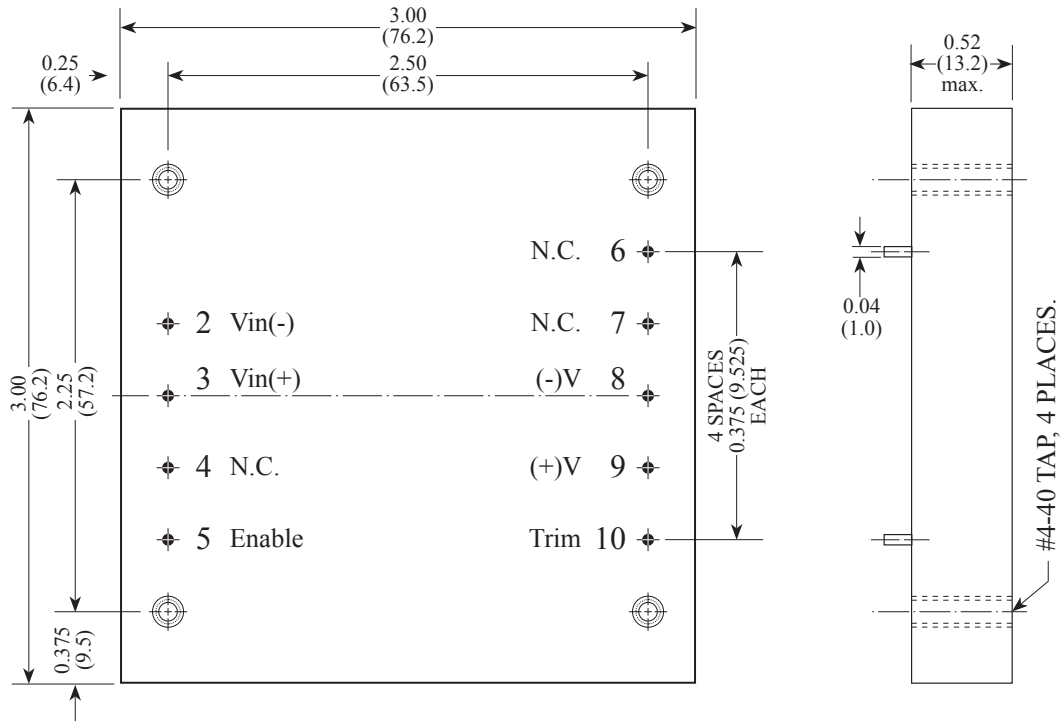

**Chassis Mount (Optional, TS Suffix)**

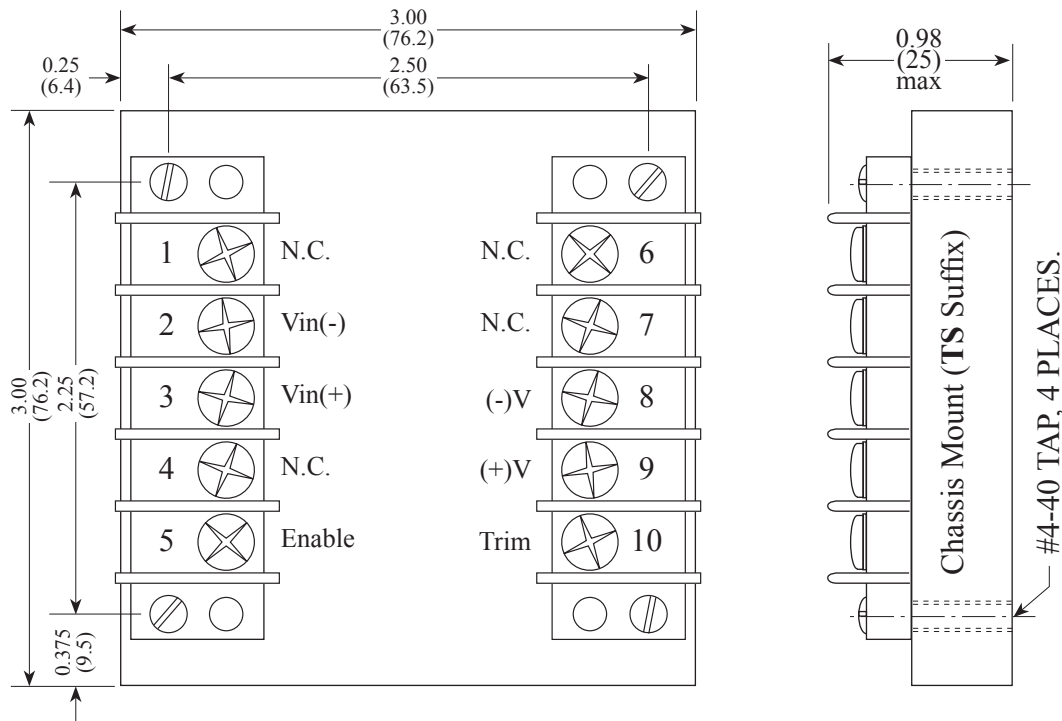

INPUT		OUTPUT										Short Circuit Protection	Over Temp. Protect	EFF. (typ.)	MODEL NO.
Nominal (Range)	Max Power (Watt)	Voltage (V)				Current (A)			Ripple & Noise						
		#	Set Point	Min.*	Max.*	#	Min.	Max.	Peak-Peak	R.M.S.					
12 (9-18)	25	±5.0V	+V1	+5.00	+4.90	+5.10	+11	+0.25	+2.5	75mV	15mV	Pulse by Pulse Current Limiting	Not Available	80%	M25D1205
			-V2	-5.00	-4.80	+5.20	-12	-0.25	-2.5	75mV	15mV			80%	M30D1212
	30	±12V	+V1	+12.00	+11.90	+12.10	+11	+0.13	+1.25	100mV	20mV			82%	M30D1215
			-V2	-12.00	-11.80	+12.20	-12	-0.13	-1.25	100mV	20mV			82%	M25D2405
	30	±15V	+V1	+15.00	+14.85	+15.15	+11	+0.1	+1.0	120mV	25mV			84%	M30D2412
			-V2	-15.00	-14.70	-15.30	-12	-0.1	-1.0	120mV	25mV			84%	M30D2415
24 (18-36)	25	±5.0V	+V1	+5.00	+4.90	+5.10	+11	+0.25	+2.5	75mV	15mV			82%	M25D4805
			-V2	-5.00	-4.80	+5.20	-12	-0.25	-2.5	75mV	15mV			84%	M30D4812
	30	±12V	+V1	+12.00	+11.90	+12.10	+11	+0.13	+1.25	100mV	20mV			84%	M30D4815
			-V2	-12.00	-11.80	+12.20	-12	-0.13	-1.25	100mV	20mV			80%	MW25D2405
	30	±15V	+V1	+15.00	+14.85	+15.15	+11	+0.1	+1.0	120mV	25mV			82%	MW30D2412
			-V2	-15.00	-14.70	-15.30	-12	-0.1	-1.0	120mV	25mV			82%	MW30D2415
48 (36 - 75)	25	±5.0V	+V1	+5.00	+4.90	+5.10	+11	+0.25	+2.5	75mV	15mV	81%	MW25D4805		
			-V2	-5.00	-4.80	+5.20	-12	-0.25	-2.5	75mV	15mV	82%	MW30D4812		
	30	±12V	+V1	+12.00	+11.90	+12.10	+11	+0.13	+1.25	100mV	20mV	82%	LW30D4815		
			-V2	-12.00	-11.80	+12.20	-12	-0.13	-1.25	100mV	20mV				
	30	±15V	+V1	+15.00	+14.85	+15.15	+11	+0.1	+1.0	120mV	25mV				
			-V2	-15.00	-14.70	-15.30	-12	-0.1	-1.0	120mV	25mV				
W-24 (10-36)	25	±5.0V	+V1	+5.00	+4.90	+5.10	+11	+0.25	+2.5	75mV	15mV				
			-V2	-5.00	-4.80	+5.20	-12	-0.25	-2.5	75mV	15mV				
	30	±12V	+V1	+12.00	+11.90	+12.10	+11	+0.13	+1.25	100mV	20mV				
			-V2	-12.00	-11.80	+12.20	-12	-0.13	-1.25	100mV	20mV				
	30	±15V	+V1	+15.00	+14.85	+15.15	+11	+0.1	+1.0	120mV	25mV				
			-V2	-15.00	-14.70	-15.30	-12	-0.1	-1.0	120mV	25mV				
W-48 (20-75)	25	±5.0V	+V1	+5.00	+4.90	+5.10	+11	+0.25	+2.5	75mV	15mV				
			-V2	-5.00	-4.80	+5.20	-12	-0.25	-2.5	75mV	15mV				
	30	±12V	+V1	+12.00	+11.90	+12.10	+11	+0.13	+1.25	100mV	20mV				
			-V2	-12.00	-11.80	+12.20	-12	-0.13	-1.25	100mV	20mV				
	30	±15V	+V1	+15.00	+14.85	+15.15	+11	+0.1	+1.0	120mV	25mV				
			-V2	-15.00	-14.70	-15.30	-12	-0.1	-1.0	120mV	25mV				

\* Combined Line & Load (Low Line to High Line, Min. Load to Full Load)

**Product Numbering System & Selection Guide**

M	25	D	24	05	TS
Series No.	Output Power	No Output	Input Voltage	+V1/-V2 Output	Options
M	25 : 25W 30 : 30W	D : Dual	12 : 9-18V 24 : 18-36V 48 : 36-75V	05 : ±5V 12 : ±12V 15 : ±15V	TS : Terminal Strips
MW			24 : 10-36V		
MW			48 : 18-75V		

**PC Board Mount**

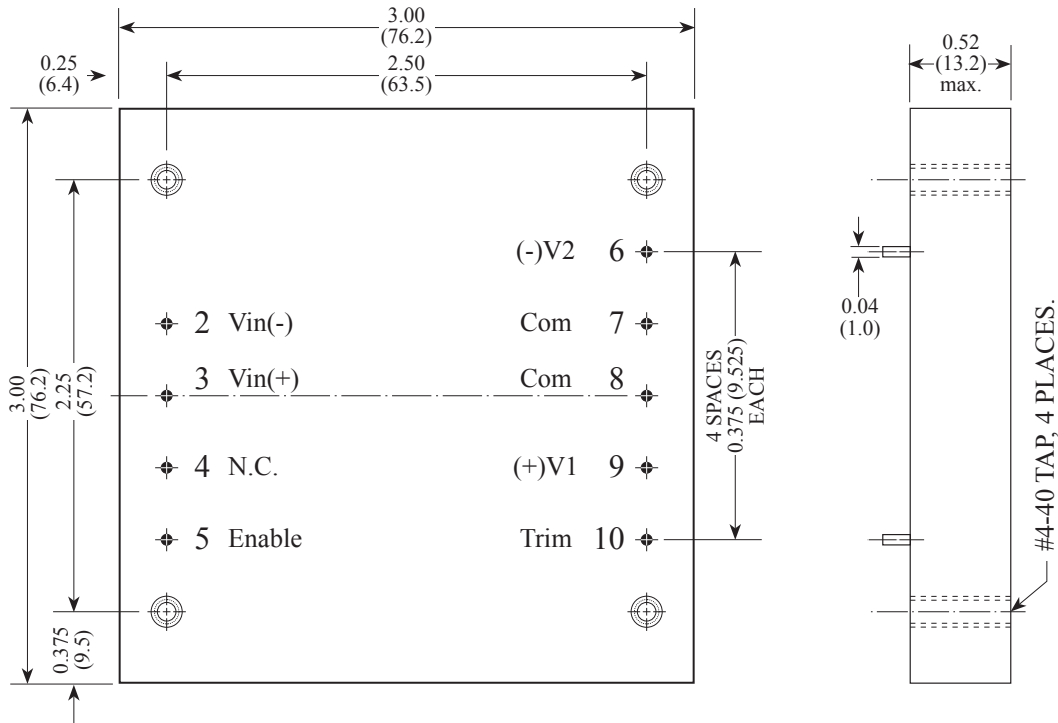

**Chassis Mount (Optional, TS Suffix)**

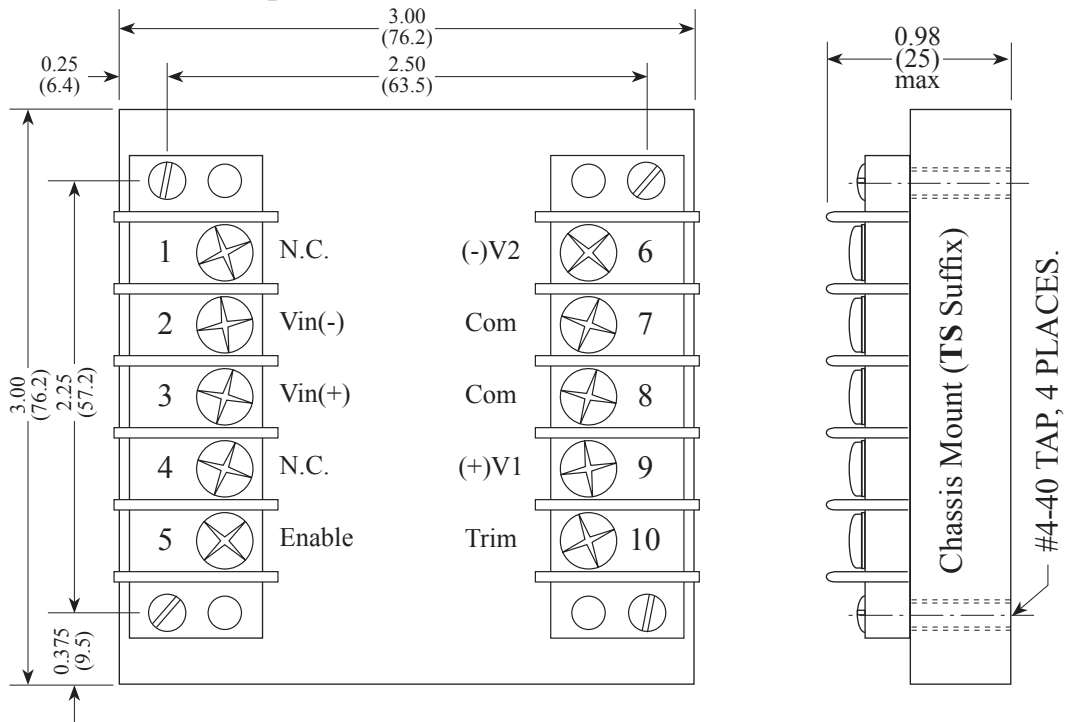

INPUT		OUTPUT										Short Circuit Protection	Over Temp. Protect	EFF. (typ.)	MODEL NO.
Nominal (Range)	Max Power (Watt)	Voltage (V)				Current (A)			Ripple & Noise						
		#	Set Point	Min.*	Max.*	#	Min.	Max.	Peak-Peak	R.M.S.					
12 (9-18)	30	+5V/+12V	+V1	+5.00	+4.90	+5.10	+I1	+0.4	+4.0	75mV	15mV	Pulse by Pulse Current Limiting	Not Available	82%	M30D1205+12
	30		+V2	+12.0	+11.40	+12.60	+I2	+0.1	+1.0	120mV	25mV			82%	M30D1205+24
24 (18-36)	30	+5V/+24V	+V1	+5.00	+4.90	+5.10	+I1	+0.4	+4.0	75mV	15mV			82%	M30D2405+12
	30		+V2	+24.0	+22.80	+25.20	+I2	+0.05	+0.5	200mV	40mV			84%	M30D2405+24
48 (36 - 75)	30	+5V/+12V	+V1	+5.00	+4.90	+5.10	+I1	+0.4	+4.0	75mV	15mV			84%	M30D4805+12
	30		+V2	+12.0	+11.40	+12.60	+I2	+0.1	+1.0	120mV	25mV			84%	M30D4805+24
W-24 (10-36)	30	+5V/+12V	+V1	+5.00	+4.90	+5.10	+I1	+0.4	+4.0	75mV	15mV			80%	MW30D2405+12
	30		+V2	+12.0	+11.40	+12.60	+I2	+0.1	+1.0	120mV	25mV			80%	MW30D2405+24
W-48 (20-75)	30	+5V/+12V	+V1	+5.00	+4.90	+5.10	+I1	+0.4	+4.0	75mV	15mV			82%	MW30D4805+12
	30		+V2	+12.0	+11.40	+12.60	+I2	+0.1	+1.0	120mV	25mV			82%	MW30D4805+24
			+V1	+5.00	+4.90	+5.10	+I1	+0.4	+4.0	75mV	15mV				
			+V2	+24.0	+22.80	+25.20	+I2	+0.05	+0.5	200mV	40mV				

\* Combined Line & Load (Low Line to High Line, Min. Load to Full Load)

**Product Numbering System & Selection Guide**

<b>M</b>	<b>30</b>	<b>T</b>	<b>24</b>	<b>05</b>	+	<b>12</b>	<b>TS</b>
Series No.	Output Power	No Output	Input Voltage	+V1 Output	+V2/-V3 Outputs	Option	
M	30 : 30W	D : Dual	12 : 9-18V 24 : 18-36V 48 : 36-75V	05 : 5.0V	12 : +12V 15 : +15V	TS : Terminal Strips	
MW			24 : 10-36V				
MW			48 : 20-75V				

**PC Board Mount**

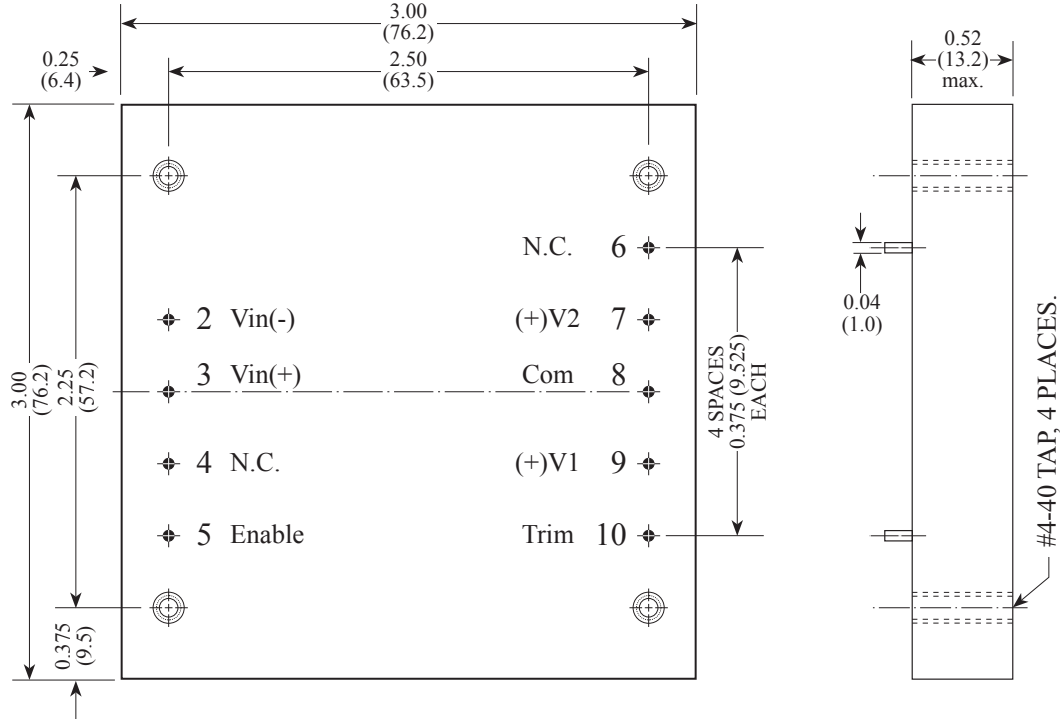

**Chassis Mount (Optional, TS Suffix)**

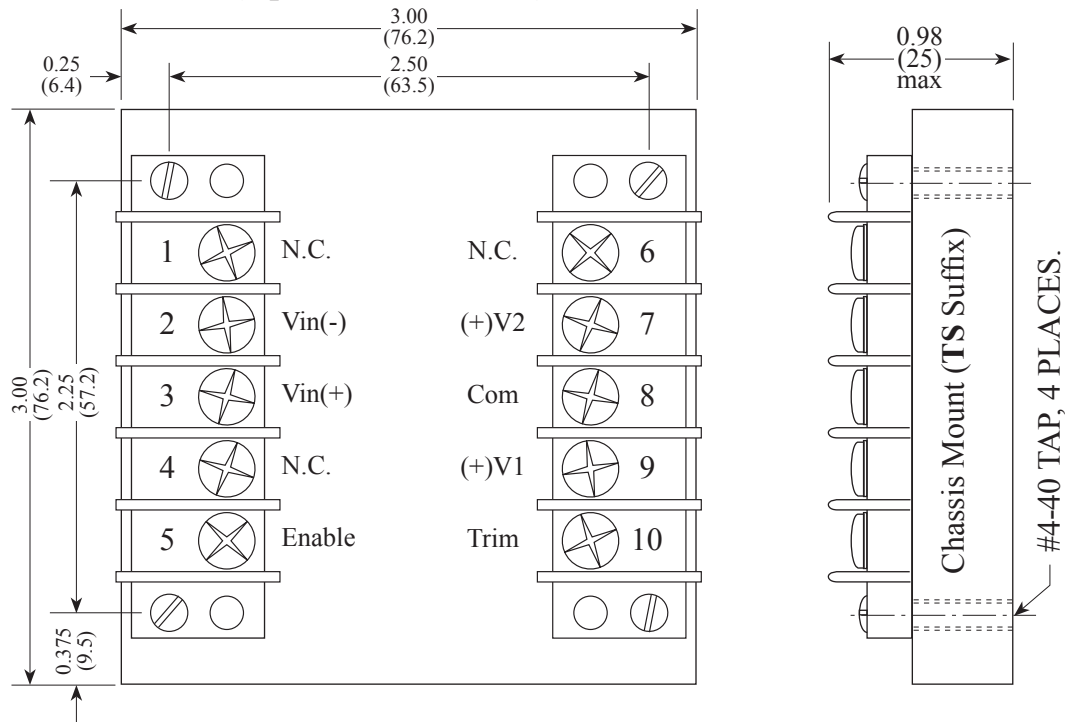

INPUT		OUTPUT										Over Temp. Shutdown /Recover	EFF. (typ.)	MODEL NO.			
Nominal (Range)	Max Output Power	Voltage (V)					Current (A)			Ripple & Noise					Short Circuit Protection		
		#	Set Point	Min.*	Max.*	#	Min.	Max.	Peak-Peak	R.M.S.							
12 (9 - 18)	30W	+5.0V ±12V	+V1	+5.00	+4.90	+5.10	+I1	+0.4	+4.0	75mV	15mV	Pulse by Pulse Current Limiting	Not Available	82%	M30T1205-12		
			+V3	+12.0	+11.0	+13.5	+I2	+0.05	+0.50	100mV	25mV						
			-V2	-12.0	-11.0	-13.5	+I3	-0.05	-0.50	100mV	25mV						
	30W	+5.0V ±15V	+V1	+5.00	+4.90	+5.10	+I1	+0.4	+4.0	75mV	15mV			82%	M30T1205-15		
			+V3	+15.0	+14.0	+16.5	+I2	+0.05	+0.50	120mV	30mV						
			-V2	-15.0	-14.5	-16.5	+I3	-0.05	-0.50	120mV	30mV						
24 (18 - 36)	30W	+5.0V ±12V	+V1	+5.00	+4.90	+5.10	+I1	+0.3	+3.0	75mV	15mV		Pulse by Pulse Current Limiting	Not Available	82%	M30T2405-12	
			+V3	+12.0	+11.0	+13.5	+I2	+0.04	+0.42	100mV	25mV						
			-V2	-12.0	-11.0	-13.5	+I3	-0.04	-0.42	100mV	25mV						
	30W	+5.0V ±15V	+V1	+5.00	+4.90	+5.10	+I1	+0.3	+3.0	75mV	15mV				82%	M30T2405-15	
			+V3	+15.0	+14.0	+16.5	+I2	+0.04	+0.34	120mV	30mV						
			-V2	-15.0	-14.5	-16.5	+I3	-0.04	-0.34	120mV	30mV						
48 (36 - 75)	30W	+5.0V ±12V	+V1	+5.00	+4.90	+5.10	+I1	+0.3	+3.0	75mV	15mV			Pulse by Pulse Current Limiting	Not Available	82%	M30T4805-12
			+V3	+12.0	+11.0	+13.5	+I2	+0.04	+0.42	100mV	25mV						
			-V2	-12.0	-11.0	-13.5	+I3	-0.04	-0.42	100mV	25mV						
	30W	+5.0V ±15V	+V1	+5.00	+4.90	+5.10	+I1	+0.3	+3.0	75mV	15mV					82%	M30T4805-15
			+V3	+15.0	+14.0	+16.5	+I2	+0.04	+0.34	120mV	30mV						
			-V2	-15.0	-14.5	-16.5	+I3	-0.04	-0.34	120mV	30mV						
W-24 (10 - 36)	30W	+5.0V ±12V	+V1	+5.00	+4.90	+5.10	+I1	+0.3	+3.0	75mV	15mV	Pulse by Pulse Current Limiting			Not Available	82%	MW30T2405-12
			+V3	+12.0	+11.0	+13.5	+I2	+0.04	+0.42	100mV	25mV						
			-V2	-12.0	-11.0	-13.5	+I3	-0.04	-0.42	100mV	25mV						
	30W	+5.0V ±15V	+V1	+5.00	+4.90	+5.10	+I1	+0.3	+3.0	75mV	15mV					82%	MW30T2405-15
			+V3	+15.0	+14.0	+16.5	+I2	+0.04	+0.34	120mV	30mV						
			-V2	-15.0	-14.5	-16.5	+I3	-0.04	-0.34	120mV	30mV						
W-48 (20 - 75)	30W	+5.0V ±12V	+V1	+5.00	+4.90	+5.10	+I1	+0.3	+3.0	75mV	15mV		Pulse by Pulse Current Limiting		Not Available	82%	MW30T4805-12
			+V3	+12.0	+11.0	+13.5	+I2	+0.04	+0.42	100mV	25mV						
			-V2	-12.0	-11.0	-13.5	+I3	-0.04	-0.42	100mV	25mV						
	30W	+5.0V ±15V	+V1	+5.00	+4.90	+5.10	+I1	+0.3	+3.0	75mV	15mV					82%	MW30T4805-15
			+V3	+15.0	+14.0	+16.5	+I2	+0.04	+0.34	120mV	30mV						
			-V2	-15.0	-14.5	-16.5	+I3	-0.04	-0.34	120mV	30mV						

\* Combined Line & Load (Low Line to High Line, Min. Load to Full Load)  
(+V1 is Regulated and +V2/-V2 are Semi-Regulated.

**Product Numbering System & Selection Guide**

<b>M</b>	<b>30</b>	<b>T</b>	<b>24</b>	<b>05</b>	<b>-</b>	<b>12</b>	<b>TS</b>
Series No.	Output Power	No Output	Input Voltage	+V1 Output	+V2/-V3 Outputs	Option	
M	30 : 30W	T : Triple	12 : 9-18V 24 : 18-36V 48 : 36-75V	05 : 5.0V	12 : ±12V 15 : ±15V	TS : Terminal Strips	
MW			24 : 10-36V 48 : 20-75V				

**PC Board Mount**

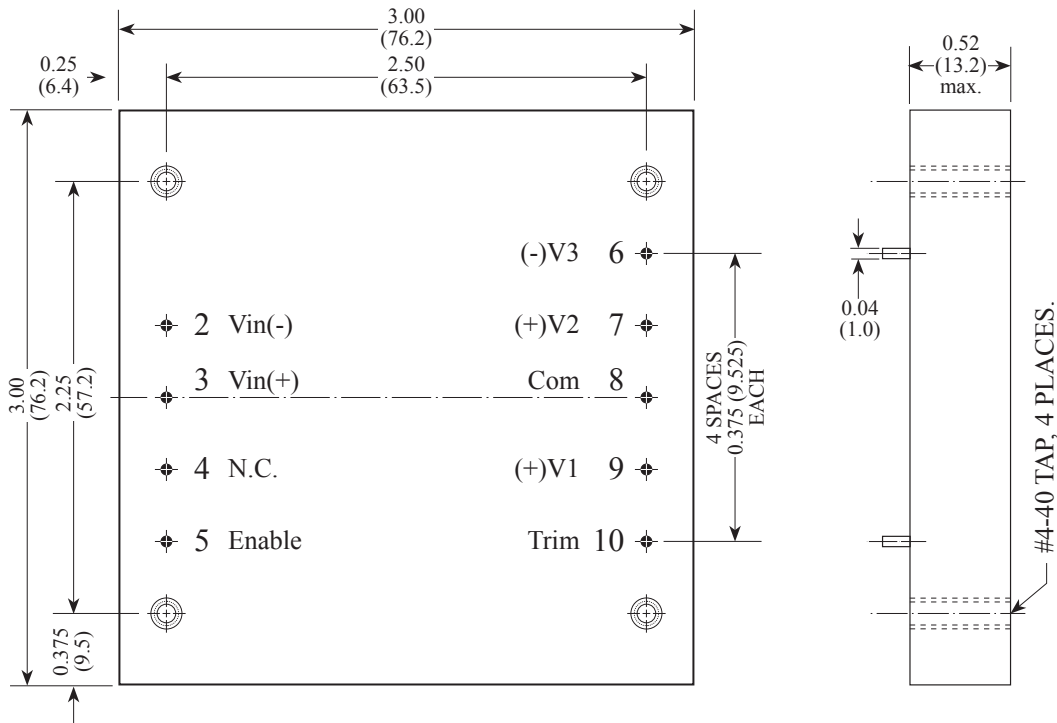

**Chassis Mount (Optional, TS Suffix)**

