



This Designers' Manual has been prepared by Powerstax experts to assist suitably qualified engineers and technicians in understanding the correct system design practices necessary to achieve maximum versatility and performance from any of the MS1U & MM1U series family of products.

Contents

Section Description

- 1 Overview of MS1U series
- 2 Part numbering system
- 3 Installation considerations
- 4 MS1U DOs and DON'Ts
- 5 Theory of operation
- 6 MS1U configuration
- 7 Power Module operation
- 8 Power Module signals
- 9 Power Unit operation
- 10 Power Unit (global) signals
- 11 Power Unit options
- 12 Power ratings
- 13 Reliability
- 14 Safety
- 15 EMC
- 16 Connectors
- 17 Mechanical specifications



Section 1 Overview of MS1U series

Part of the *MULTISTAX*® range from Powerstax plc, the MS1U series allows users to instantly configure high efficiency, off-line power supplies. Although very small in size, (40.4mm wide, 260mm long and either 89mm or 127mm wide) the MS1U series provides up to 1,200W of output power. The chassis has 4 or 6 slots and can provide up to 12 isolated outputs.

A complete power supply is configured by selecting and inserting up to six same length slide-in output assemblies called *Power Modules* incorporating high efficiency switching techniques and leading edge technologies from Powerstax and available in a wide array of output voltages and power levels. The net result is a power supply that offers the advantages of a custom supply, but is assembled from standard and modular building blocks continuing the Powerstax tradition of industry leading configurable power supplies.

For detailed information about the *Power Modules*, refer to the *Power Modules* datasheet and/or this designers' manual. Manufactured in world class power supply facilities under Powerstax control, the MS1U series is completely user configurable. If output requirements change, i.e., more power or a different output voltage is needed, upgrading is easy: simply unlock a single screw and replace the slide-in Power Module assembly with the preferred alternative. Allowing additional flexibility, *Power Modules* can be connected in parallel to increase output power, or in series for higher voltages (subject to staying within isolation ratings and giving due consideration to any SELV requirements).

A user-friendly interface on connector J3 of each *Power Modules* provides control and output sequencing capability, in addition to useful status indicators. Please consult our Powerstax applications team if you have other special requirements.

The MS1U series power supplies combine feature-laden front-ends (Power Units) with slide-in output converters (*Power Modules*). The plug-together architecture facilitates 'instant' custom power solutions with industry leading 15W/in³ power density and up to 90% conversion efficiency. Available in two package sizes, with a variety of application specific *Power Units*, the MS1U series provides a standard off-the-shelf solution for specific application requirements.

The tables overleaf summarise various model families in the MS1U series together with a summary of the outline specifications for each model.



Power Units

General Applications (4slot package, 89mm wide)

Family	Model	Slots	Power	Width
MS1U	4A	4	200W	89mm
	4B	4	400W	89mm
	4C	4	600W	89mm

General Applications (6slot package, 127mm wide)

Family	Model	Slots	Power	Width
MS1U	6A	6	400W	127mm
	6B	6	700W	127mm
	6C	6	1000W	127mm
	6D	6	1200W	127mm

High Temperature (6slot package, 127mm wide)

Family	Model	Slots	Power	Width
MS1U	6H	6	400W	127mm
	6J	6	600W	127mm

Low Acoustics (4slot package, 89mm wide)

Family	Model	Slots	Power	Width
MS1U	4L	4	200W	89mm
	4M	4	400W	89mm

Low Acoustics (6slot package, 127mm wide)

Family	Model	Slots	Power	Width
MS1U	6L	6	400W	127mm
	6M	6	900W	127mm

Medical Applications (4slot package, 89mm wide)

Family	Model	Slots	Power	Width
MM1U	4A	4	200W	89mm
	4B	4	400W	89mm
	4C	4	600W	89mm

Medical Applications (6slot package, 127mm wide)

Family	Model	Slots	Power	Width
MM1U	6A	6	400W	127mm
	6B	6	700W	127mm
	6C	6	1000W	127mm
	6D	6	1200W	127mm

Medical Low Acoustics (4slot package, 89mm wide)

Family	Model	Slots	Power	Width
MM1U	4L	4	200W	89mm
	4M	4	400W	89mm

Low Acoustics (6slot package, 127mm wide)

Family	Model	Slots	Power	Width
MM1U	6L	6	400W	127mm
	6M	6	900W	127mm

Power Modules

MODEL	Vmin	Vnom	Vmax	I _{max}	Watts*
Mx1	1.5	2.5	3.6	50A	125W
Mx2	3.2	5	6	40A	200W
Mx3	6	12	15	20A	240W
Mx4	12	24	30	10A	240W
Mx5	28	48	58	6A	288W
Mx7	5	24	28	5A	120W
Mx8 v1	5	24	28	3A	72W
v2	5	24	28	3A	72W

Standard Features

- Input Voltage: 85V to 264Vac 47 to 63 Hz
- Outputs: 6 slots (up to 12 outputs)
- Full power output to 50°C; half power to 70°C
- Low inrush current
- Integral Field Replaceable fan
- Conducted EMI meets EN 55022 Level B
- AC Fail status signal
- Output Sequencing capability
- Global shutdown capability
- Overcurrent protection standard on all outputs.
- Overvoltage protection on all *Power Module* outputs
- Overtemperature limiting on all *Power Modules*
- Safety Agency Approvals: CE Mark, UL, CSA
- DC OK (Power Good) status signal
- Wide output voltage adjustment range

Optional Features

- Thermal Signals suite (Over Temp and Fan Fail signals)
- Reversed fan airflow direction

Section 2 Part numbering system

The part numbering system (explained below) clearly identifies which *Power Modules* are factory installed into particular *Power Units*. This is also clearly indicated on the output label situated on top of the power supply.

Full specifications for each model are given in the relevant family datasheets.

Powerstax - MS1U - 6C - 123400 - 01

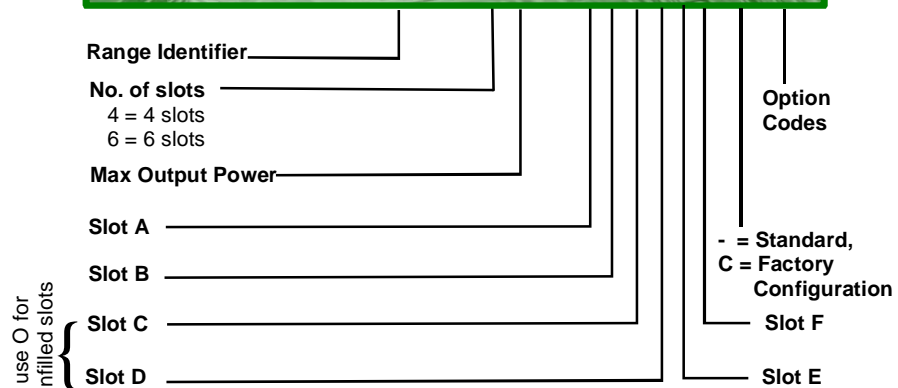

Section 3 Installation Considerations

MS1U series models may be mounted on any of three surfaces using standard M4 screws. The chassis comes with four mounting points on the base; maximum allowable torque is 2Nm. The maximum penetration depth is 6mm. Additionally, the Fleximount system on both side walls of the Power Unit chassis facilitates flexible mounting.

When selecting a mounting location and orientation, the unit should be positioned so air flow is not restricted. Maintain a 50mm minimum clearance at both ends of the MS1U power supply and route all cables so airflow is not obstructed. The standard unit draws air in on the input side and exhausts air out the load side. If airflow ducting is used, avoid sharp turns that could create back pressure. The fan moves approximately 10Litres/sec (20 CFM) of air.

Avoid excessive bending of output power cables after they are connected to the MS1U Power Modules. For high-current outputs, use cable-ties to support heavy cables and minimise mechanical stress on output studs. Be careful not to short-out to neighbouring output studs. MS1U Power Modules are supplied with spring washers on all output screws. These (or equivalents) should be used and thread locking compounds are not required. The maximum torque recommended on output connectors is 4Nm. Avoid applications in which the unit is exposed to excessive shock or vibration levels that exceed the specified levels. In such applications, a shock absorption mounting design is required.

Section 4 MS1U DOs and DON'Ts

- Always fill all output slots of the MS1U. If a slot is not filled with a Power Module, it should be filled with an Empty Slot Cover (part numbers XB1, XB2 or XB3). Empty Slot covers are plastic assemblies whose main function is maintain proper airflow. Excessive airflow escape from an empty slot may degrade thermal performance, and result in overheating and damage to the MS1U unit.
- Do not unplug or plug in Power Modules while input

- power is applied to the Power Unit. The MS1U series is not designed for hot-plug applications.
- Do not restrict airflow to the unit. The cooling fan draws air into the unit and forces it out at the output terminals.
- Always ensure that output screws are properly torqued before applying power to the Power Unit.
- Positive and Negative power cables should be run next to each other to minimise inductance.
- Wait 2 minutes after shutting off power before inserting or removing Power Modules.
- MS1U assemblies do not have user serviceable components. They must be returned to the factory for repairs. Contact Customer Service for a RMA number before returning the unit. Do not attempt to repair or modify the power supply in any manner other than the exchange of Power Modules as described in this Designers' Manual.
- Use proper size wires to avoid overheating and excessive voltage drop.

Section 5 Theory of operation

The MS1U is comprised of an appropriate Power Unit and a selection of Power Module DC output modules selected to deliver the exact volts and amps requirements of the system designer. See the operational block diagram below.

The MS1U Power Unit modules consist of a fan-cooled semienclosed chassis containing circuitry for an off-line single phase AC front end, EMI filter, cooling fan, system interface and associated housekeeping circuits. Input AC mains voltage (L1/N, L2 and GND) is applied to an IEC320 type input connector and then through an EMI filter designed to meet EN 55022 Level B. For medical applications, the EMI filter also ensures that the power supply meets the low earth leakage current requirements EN60601-01.

At start-up, inrush current is limited by an active soft-start circuit integrated with the power rectifier circuitry. This stage is then followed by a high frequency switching input current shaping boost converter feeding the ZVS (Zero Voltage Switching) resonant switching stage.

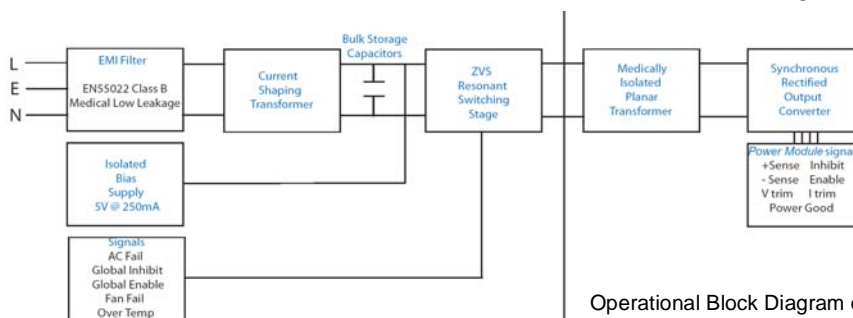

Operational Block Diagram of MS1U Series

Section 3 Installation Considerations

The ZVS stage supplies power to a variety of Power Module assemblies that provide the desired low voltage, regulated outputs. Conversion in the output assemblies is achieved by the most advanced high efficiency converters resulting in reduced size for magnetics and capacitors; excellent line and load regulation; wide adjustment range for output; and low EMI/RFI emission.

At initial power-up, the MS1U outputs are disabled to eliminate inrush current, a low-power flyback converter operating with PWM current-mode control converts the high voltage bus into regulated low voltage to power the internal housekeeping circuits and cooling fans. Once the bus potential is within operating parameters, the AC Fail signal is activated indicating that the input power is OK, and allows the installed *Power Module* outputs to come up. An auxiliary bias supply of 5 Vdc rated at 250mA is provided for peripheral use on interface connector J2. In the case of medically approved supplies, this bias supply has medical isolation (4000VAC)

Outputs may be either globally enabled or inhibited via contact closure signals applied to J2.

Section 6 Configuration (& Reconfiguration)

Power Modules may be easily added, replaced, or moved by sliding the assemblies in or out of a Power Unit chassis.

Prior to removing or installing a Power Module module, remove power from the *Power Unit* and wait 2 minutes. Failure to do so can result in personal injury and/or damage to the supply. Take standard ESD precautions when handling *Power Modules*.

Removing Power Modules

Power Modules may be removed by removing the screw on the top surface. Once this screw has been removed the *Power Module* will slide out of the chassis. Once a *Power Module* has been removed, the empty slot MUST be filled with either another Power Module or an empty slot cover. If the slot is left empty, it will provide an air-flow escape and may cause inadvertent shutdown of the unit.

Installing Power Modules

Power Modules may be installed in empty slots by simply sliding in the new Power Module, pushing the module 'home' until the mounting bracket lines up with the hole in the Top Panel, then securing the module with the M3 x 6 countersunk screw provided. Power and interface connections can be made after the *Power Module* has been installed.

Power Modules may be paralleled for more power using bus bars (paralleling Links) across the positive and negative output terminals. See Section 7, Power Module operation: Parallel Connection of Power Module outputs

Section 7 Power Module operation

The MS1U series of products have been designed to allow maximum flexibility in meeting the unique requirements of individual users. The inherent flexibility resulting from modularity concepts is further enhanced by this flexibility. Although the products are very versatile, care should always be taken to ensure that the proper procedures are followed.

Voltage Adjustment

The MS1U series has been designed with maximum user flexibility as a key objective. With regards to voltage adjustment this has been achieved by the wide range of adjustment on each of the Power Module models. Voltage adjustment may be achieved by:

1. Front-panel potentiometer adjustment (all *Power Modules*)
2. Remote resistive programming (*Power Modules* Mx1-Mx5)
3. Remote voltage programming (*Power Modules* Mx1-Mx5)

See diagrams below for details on external connections to the V trim pin (J3 pin3) required for remote voltage programming.

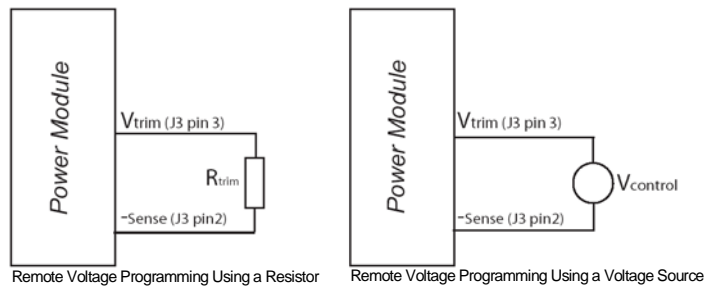

Remote Voltage Programming using a Voltage Source

Using an external Voltage source ($V_{control}$), the *Power Module* output voltage may be adjusted over a wide range. The *Power Module* output voltage may be programmed by referring to the Voltage Programming graph and applying formula below to set the *Power Module* output voltage to the required level.

$$V_{output} = K \times V_{control} \tag{1}$$

The appropriate K factor for different *Power Modules* are in Voltage Programming table.

Important: $V_{control}$ must not exceed 2.5V.

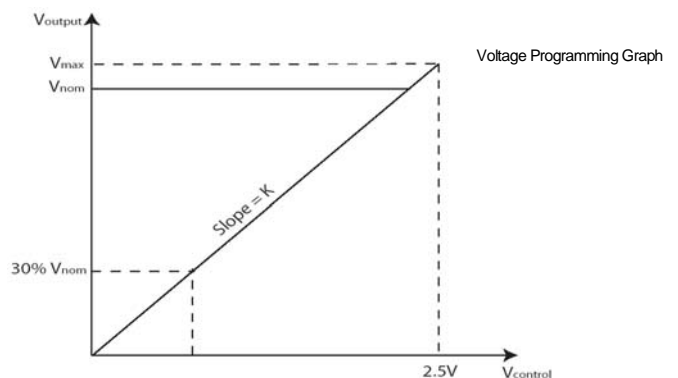

Voltage Programming Table	
Power Module	K
Mx1	2.5
Mx2	2.5
Mx3	6.25
Mx4	12.5
Mx5	24.25



MODEL	Vmin (V)	Vnom (V)	Vmax (V)	I _{max}	I limit adjust min max	Current Limit Onset SC*	I foldback	V trim range min max	I trim range min max	OVP 1 tracking % of Vset	OVP 2 Fixed % of Vmax	Remote Sense	J3 signals	
Mx1	1.5	2.5	3.6	50A	0A / 55.0A	55.0A / 58.0A	Yes	0.75V / 4.0V	0A / 55.0A	110-115%	110-125%	0.5V	-sense Itrim Enable -PG	+sense Vtrim Inhibit +PG
Mx2	3.2	5	6	40A	0A / 44.0A	44.0A / 46.0A	Yes	1.5V / 6.6V	0A / 44.0A	110-115%	110-125%	0.5V	-sense Itrim Enable -PG	+sense Vtrim Inhibit +PG
Mx3	6	12	15	20A	0A / 22.0A	22.0A / 23.0A	Yes	3.6V / 16.5V	0A / 22.0A	110-115%	110-125%	0.5V	-sense Itrim Enable -PG	+sense Vtrim Inhibit +PG
Mx4	12	24	30	10A	0A / 11.0A	11.0A / 12.0A	Yes	7.2V / 33.0V	0A / 11.0A	110-115%	110-125%	0.5V	-sense Itrim Enable -PG	+sense Vtrim Inhibit +PG
Mx5	28	48	58	6A	0A / 6.6A	6.6A / 7.0A	Yes	14.4V / 59.0V	0A / 6.6A	110-115%	110-125%	0.5V	-sense Itrim Enable -PG	+sense Vtrim Inhibit +PG
Mx7	5	24	28	No	0A / 55.0A	5.5A / 6.0A	No	No	No	No	110-125%	No	+PG -PG Inhibit Common	
Mx8 v1	5	24	28	No	0A / 55.0A	3.3A / 4.0A	No	No	No	No	110-125%	No	V1	V2
v2	5	24	28	No	0A / 55.0A	3.3A / 4.0A	No	No	No	No	110-125%	No	+PG -PG Inhibit Common	+PG -PG Inhibit Common

*sc = Short Circuit Current Limit

Example:
Using a *Power Module* Mx4, what external voltage must be applied to Vtrim pin in order to set *Power Module* output voltage to 20V.

$V_{\text{output}} = 20V, K=12.5$
Using equation (1); $V_{\text{output}}/K=V_{\text{control}}$
 $20V/12.5 = 1.6V.$
 $V_{\text{control}} = 1.6V$

Remote Voltage Programming using a Resistor.

The *Power Module* output voltage can be adjusted downwards using a remote potentiometer, or reduced, using an external resistance.

Calculation of the external resistance depends on the actual initial voltage setting of the *Power Module* (via the onboard potentiometer). The preferred method is to set the *Power Module* voltage to its maximum rating. e.g. Mx4 set to 30V. This will allow the widest possible adjustment range of the output voltage.

Power Module set to Vmax (Vmax=1)
For modules Mx1 and Mx2

$R_{\text{trim}} = \frac{[3700V_{\text{out}} - 167.5]}{[1.675K - V_{\text{out}}]}$ (2)

For module Mx3, Mx4 and Mx5

$R_{\text{trim}} = \frac{[3700V_{\text{out}} - 227.5K]}{[2.275K - V_{\text{out}}]}$ (3)

Example.

Using a *Power Module* Mx4, determine the resistance value to be applied to Vtrim pin in order to set *Power Module* output voltage to 20V.

K for Mx4 = 12.5
 $V_{\text{out}} = 20V$
Using equation (3)

$R_{\text{trim}} = 8433 \text{ ohm}$

Alternatively if the *Power Module* voltage is set to via the onboard potentiometer to another level e.g. 21V then the following formula must be used to calculate the value of Rtrim

For *Power Module* Mx1 and Mx2

$R_{\text{trim}} = \frac{V_{\text{out}}[(3700 + 10KV_p(1 - V_p)) - K(100V_p + 67.5)]}{K(V_p + 0.675) - V_{\text{out}}}$ (4)

For *Power Module* Mx3, Mx4 and Mx5

$R_{\text{trim}} = \frac{V_{\text{out}}[(3700 + 10KV_p(1 - V_p)) - K(100V_p + 127.50)]}{[K(V_p + 1.275) - V_{\text{out}}]}$ (5)

where V_p is the *Power Module* setpoint voltage expressed as a proportion of the total trim range.

$V_p = \frac{(V_{\text{max}} - V_{\text{min}})}{(V_{\text{set}} - V_{\text{min}})}$ (6)

Example.

To set *Power Module* Mx4 to 15V when *Power Module* Vset is 21V

Using equation (6) $V_p = \frac{(30 - 12)}{(21 - 12)}$

$V_p = 0.5$
 $K = 12.5$
 $V_{\text{out}} = 15V$

Using equation (5)

$$R_{trim} = \frac{V_{out}[(3700 + 10KV_p(1-V_p)) - K(100V_p + 127.5)]}{[K(V_p + 1.275) - V_{out}]}$$

$$R_{trim} = 7478 \text{ ohm}$$

The power rating of the trim resistor can be as low at 100mW

Over Current Protection (OCP)

A variety of over current protection methods are possible with the MS1U series. See the *Power Module* table which indicates the available current limit modes on each unit.

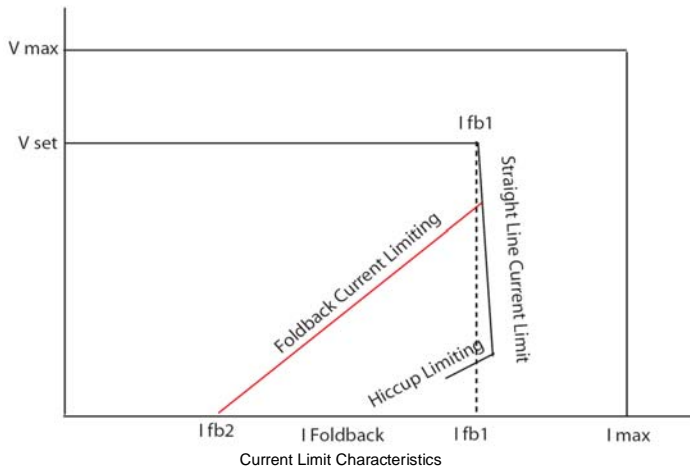

Power Modules Mx1 to Mx5 can have Straight-line current limit or Foldback current limit. See *Power Module* table for nominal current limit values.

Simple external application circuits may be used to achieve programmable foldback current and user programmable current limit levels (reduced). See Current Limit Programming diagrams and Current Limit Characteristics diagram.

The default current limit characteristic is Straight Line Current Limit.

Programming Current Limit

The current limit can be programmed to your requirements (in both Straight line and Foldback modes).

Straight line Current Limit can be programmed using an external voltage source or resistor/potentiometer. Connection between the Itrim pin (J3 pin4 and the -Vout terminal will set the current limit to the desired level.

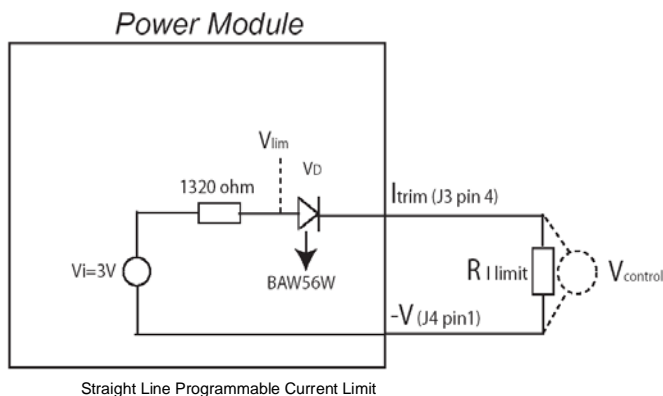

Straight Line Current Limit Using a Voltage Source.

The formula below will calculate the required external control voltage required to set the current limit of a *Power Module*:

$$V_{control} = F I_{lim} - V_D + 1 \tag{7}$$

Where F is a conversion factor for each *Power Module*.

Current Limit Table	
Power Module	F
Mx1	0.0308
Mx2	0.0308
Mx3	0.09108
Mx4	0.14935
Mx5	0.2987

VD is the voltage drop across BAW56W. This can be assumed to be 0.5V for calculations, however it will vary slightly due to temperature. Refer to BAW56W datasheet for further details.

Example:

To set the current limit of Mx1 to 20A, determine the external voltage to be applied to the Itrim pin.

$$I_{lim} = 20A$$

$$F = 0.0308 \text{ for Mx1}$$

$$V_D = 0.5V$$

Using equation (7)

$$V_{control} = 1.116V$$

Note that application of any voltage >2.5V to Itrim will not increase current limit beyond the Power Modules normal current limit.

Straight Line Current Limit Using an External Resistor.

The formula below will calculate the required external resistor value required to set the current limit of a *Power Module*:

$$R_{I \text{ limit}} = \frac{1320[(3-V_D) - 1]}{(2-F I_{lim})} \tag{8}$$

Example:

To set the current limit of Mx2 to 30A, what resistance must be placed between the Itrim pin and -V.

$$I_{lim} = 30A$$

$$F = 0.0308 \text{ for Mx1}$$

$$V_D = 0.5V$$

Using equation (8)

$$R_{I \text{ limit}} = 1747 \text{ ohm}$$

Foldback Current limit Programming

Foldback Current Limit can be achieved using the circuit overleaf. The onset of Foldback current limit (I fb1) can be programmed using the formula below as can the actual end point (I fb2).

To set the final Foldback current limit point (I fb2), the value R1 in parallel with R2 is equivalent to R I limit in the previous Straight Line current limit example.

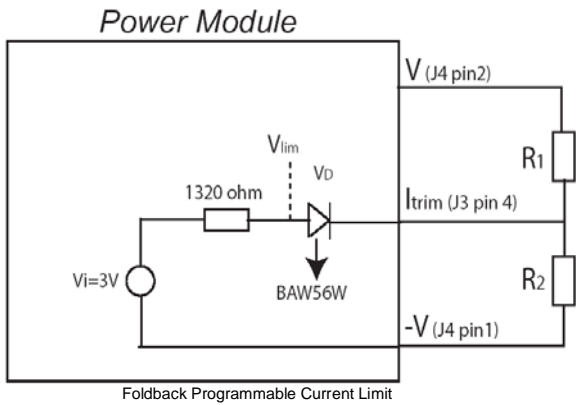

2nd Level Overvoltage protection is Latching and it may be reset by removing and reinstating AC power from the MS1U *Power Unit* input.

Power Limit.

Each *Power Module* has a number of levels of protection in order to ensure that MS1U is not damaged if used in overload conditions. See graph below.

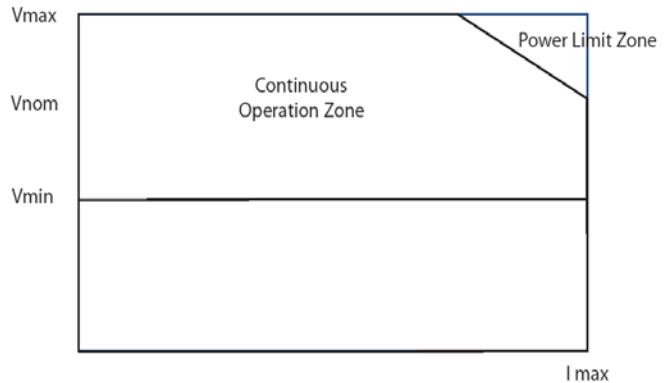

When V_{set} is less than or equal to V_{nom} , current limit is employed at the current limit set point. However if V_{set} is greater than V_{nom} , power limit is employed to ensure that the powerMods does not exceed its power rating. e.g. Mx4 is adjustable between 12V and 30V. I_{max} is 10A. Power rating is 240W. At 24V the Power Module can deliver 10A continuously, i.e 240W. However at 30V, the Power Module can still deliver 240W, however this equates to 8A continuous.

Remote Sense

To compensate for voltage drops in the output leads, use remote sensing. Remote sensing is available on all single output modules and on the first output (V1) on dual modules.

Remote sensing may be implemented by connecting the Positive Sense pin (J3 pin1) to the positive side of the remote load and the Negative Sense pin (J3 pin2) to the negative side of the remote load. The maximum line drop, which can be compensated for by remote sensing, is 0.5V, subject to not exceeding the maximum module voltage at the output terminals.

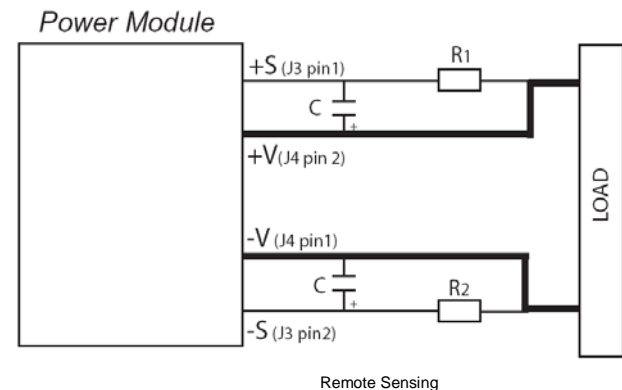

To set I_{fb1} , point, we must calculate the ratio of R1 to R2.

To get the value of R1:

$$R1 = \frac{(R \ I \ limit)V_{out}}{[F I_{fb1}(1 + R \ I \ limit) - 2R \ I \ limit + 1 - V_D]} \quad (9)$$

$$R2 = \frac{(R1)(R \ I \ limit)}{R1 - R \ I \ limit} \quad (10)$$

Example

To set the foldback current limit of an Mx2 set at 5V to the following levels, $I_{fb1} = 30A$ and $I_{fb2} = 20A$, determine the values of R1 to R2. required.

- V_{out} 5V
- $F = 0.308$
- $I_{fb1} = 30A$
- $I_{fb2} = 20A$
- $V_D = 0.5V$

To set I_{fb2} to 20A, we need the to set $R \ I \ limit$ equivalent parallel resistance of R1 in parallel with R2.

Using equation (8)
 $R \ I \ limit = 1320 \left[\frac{(3 - V_D) - 1}{(2 - F I_{fb2})} \right]$

$R \ I \ limit = 1064 \text{ ohm.}$

To calculate the ratio of R1 to R2 use the formula above Use equation (9) to get the value of R1

$R1 = 9556 \text{ ohm}$

Use equation (10) to get the value of R2

$R2 = 1197 \text{ ohm}$

Over Voltage Protection (OVP)

Over-voltage protection is implemented on each MS1U *Power Module* output as a two-level scheme, where the 1st level of protection tracks the set voltage V_{set} and the 2nd level of protection is set at a fixed level.

1st Level: 110-115% of V_{set} (where V_{set} is less than V_{max} of *Power Module*. This is only available on *Power Modules* Mx1-Mx5.

2nd level: OVP level is fixed relative to V_{max} 110-125% (Latching).

Observe the following precautions when remote sensing:
 1. Use separate twisted pairs for power and sense wiring.
 2. Route the sensing leads to prevent pick up, which may appear as ripple on the output.
 3. Never disconnect the output power rail with the sensing still connected to the load.

In certain applications where there is a high dynamic impedance along the power leads to the sensing point; remote sensing may cause system instability. This system problem can be overcome by using resistors in the sense leads (Positive sense lead: R1 = 100ohm , Negative sense lead: R2=10ohm), together with local AC sensing, by using 22uF capacitors between the remote sense pins and the output terminals.

The resistance of the power cables must be so that the voltage drop across the cables is less than 0.5V (to ensure remote sensing operates correctly).

$$R_{cable} < \frac{0.5}{I_{out}}$$

e.g for an Mx2, 5V/40A. The R_{cable} must be less than 12.5mohms

Measurement of Ripple & Noise

As with all switched mode power supplies, it is important to ensure that the correct method is used to verify ripple & noise. Care should be taken to ensure that a loop antenna is not formed by the tip and ground lead of the oscilloscope probe as this would lead to erroneous readings consisting mainly of pickup from remnant radiation in the vicinity of the output connectors. Powerstax recommends the use of a x1 probe with the ground sheath of the probe tip used for ground connection.

In some applications, further erroneous readings may result from CM currents. These can be reduced by looping a few turns of the scope lead through a suitable high permeability ferrite ring.

As most loads powered by a power supply will have at least small values of differential capacitors located near the load, Powerstax also recommends the use of small value of capacitance (approx 1uF) positioned at the point of measurement.

Minimising System Noise

There are a number of causes of poor system noise performance. Some of the more common cause are listed below.

- a. Insufficient de-coupling on the PCB or load
- b. Faulty wiring connection or poor cable terminations
- c. Poor system earthing

There are some simple steps to eliminate, reduce or identify the causes of high frequency noise

- a. Is the noise conducted or radiated? If changing the position of the power supply or screening improves performance, the noise is likely to be radiated. See Section 15. EMC: Guidelines for Optimum EMC Performance.
- b. Twist all pairs of power and sense cables separately
- c. Ground connections (zero Volt) should be made with the shortest possible wiring via a capacitor to the nearest point on the chassis.

Series Connection of Power Module outputs

It is possible to connect Power Modules in series to increase output voltage.

Outputs are rated SELV (Safety Extra Low Voltage), that is, output voltages are guaranteed to less than 60 volts. Stacking Power Modules can exceed SELV, the user must take appropriate precautions. It is good practice to stack Power Modules with similar output current limits, so that in the case of short circuit the outputs collapse together,

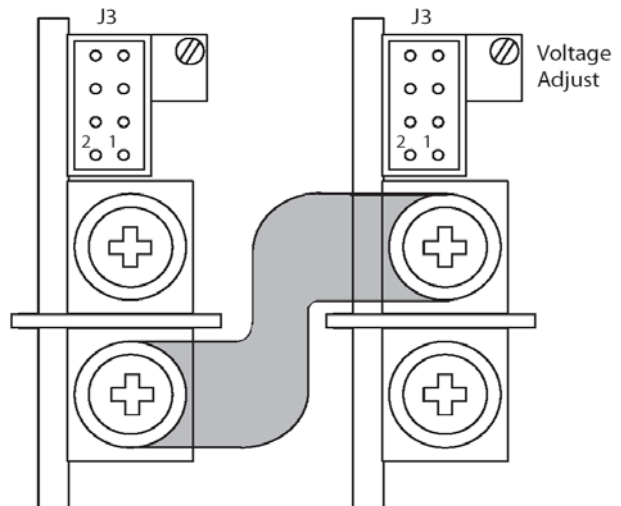

If remote sensing is required, the exterior sense connections should connect to the load at point of use, and the interior connections to the local sense. Special links for series connection of Power Modules (part number XS1) to reduce wiring complexity can be specified and fitted by the installer or added at the factory.

Parallel Connection of Power Modules outputs

Power Modules may be paralleled to increase output current. Only Power Modules of the same type may be paralleled and the installer should adjust the setting on each Power Modules separately to the same value. i.e within 0.1% of the set voltage.

Powerstax supplies special parallel link connection bars (part number XP1) for parallel connection to reduce wiring complexity. These can be specified and fitted by the installer or added at the factory.

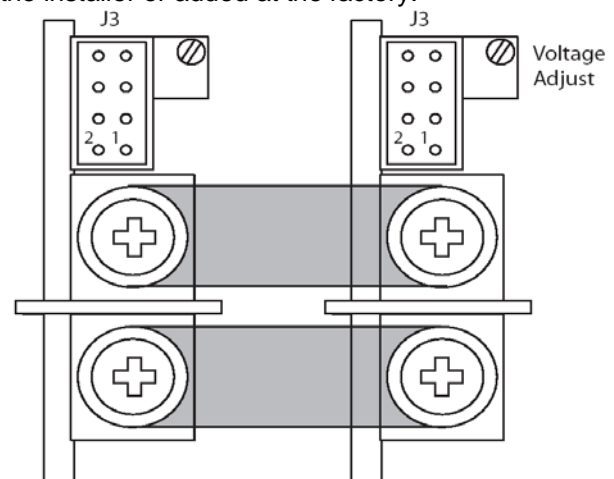

There are two methods of parallel connection.

Level 1 Paralleling.

Current Share (*Power Module* DIP switch Ishare OFF), does not force current sharing.

Level 2 Paralleling: (Recommended)

This ensures current sharing between paralleled modules and is the recommended mode for paralleling *Power Modules*. Current Sharing is proportional to the dV (difference between the voltage settings of the *Power Modules*). When connecting *Power Modules* in parallel, please observe the following steps.

1. Attach the negative Parallel Link.
2. For Level 2 Paralleling, ensure that the *Power Module* DIP switch on each *Power Module* is switched to Ishare ON
3. Set the voltage of *Power Module* 1 to the correct output required.
4. Measure the voltage difference (dV) between the positive terminals of the *Power Modules* and adjust *Power Module* 2 to minimise dV.
5. Attach the positive parallel link.

The percentage of current sharing is calculated as follows/
 IShare error% = $\frac{10000dV}{1.5V}$

(11)

Remote Sense can be implemented as with a single *Power Module*. Simply connect the sense pins of the paralleled *Power Modules*. Bring the sense connections from one of the

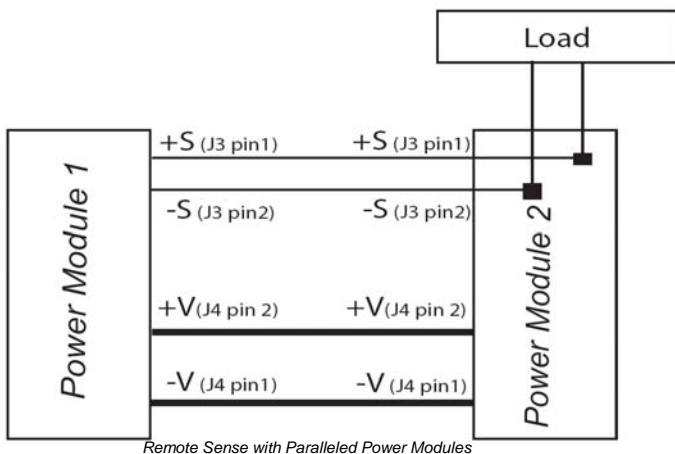

Power Module to the load.

For Remote Voltage Adjustment of *Power Module*, please contact factory.

Power Module Start-Up and Shutdown

Power Modules are designed such that when input power is applied, all outputs rise to their set point voltage simultaneously.

Like wise, when input power is removed all outputs commence to drop simultaneously and reach Zero potential simultaneously.

Outputs can be sequenced using the enable function in order to allow controlled start up if required.

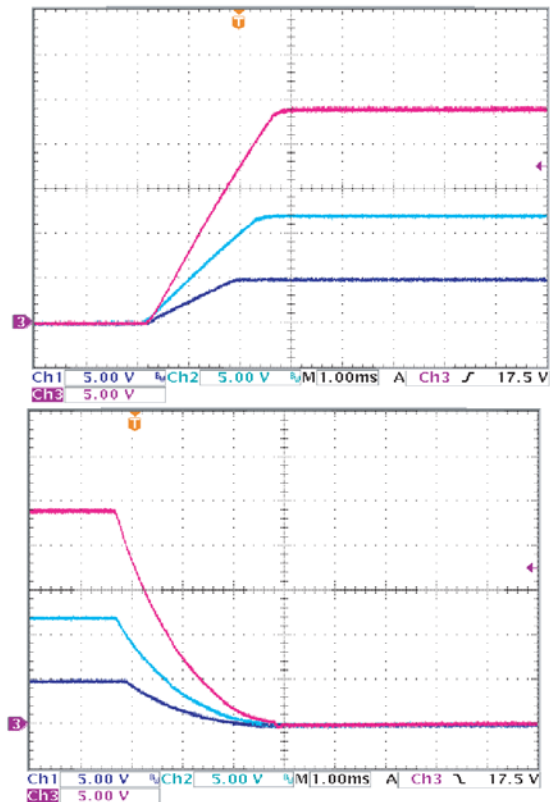

Section 8 Power Module Signals

Power Module Enable/Inhibit

Each *Power Module* may be enabled/inhibited by means of an appropriate signal applied to an opto-isolated input on pins J3 pin 5 and J3 pin 6, on *Power Modules* Mx1 to Mx5. Inhibit is available on J3 pin 7 on Mx7 and J3 pin3 and J3 pin 7 on Mx8.

The output voltage of the *Power Module* will be fully inhibited to 0V.

Maximum signal input voltage 12V.

Minimum signal input voltage 3V.

Minimum current required is 2mA.

The default mode is 'Inhibiting'. This may be changed to 'Enabling' by setting of the DIP switch on the *Power Module*.

Power Module Power Good Signal

Each powerMod contains an internal comparator which monitors the output voltage and determines whether this voltage is within normal operation limits.

Maximum collector current is 2mA

Maximum Collector voltage is 30V

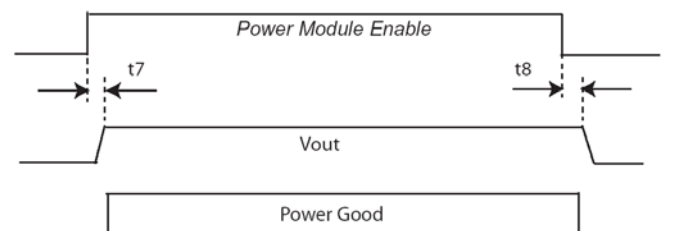

t7 <30ms
 T8 <30ms

When the output voltage is within normal limits, the Power Good signal is activated.

An opto-isolated signal is generated and available on J3 pin 7 and J3 pin 8. (opto-transistor ON = Good) for *Power Modules* Mx1 to Mx5. Available on J3 pin 5 and J3 pin 6 for Mx7, on J3 Pin1 pin2, pin 5 and pin 6 for Mx8.

Power Module LED Indicator

The LED indicator on each *Power Module* module gives a visual indication of the information contained in the Power Good signal above.

Section 9 Power Unit operation

The MS1U *Power Unit* provides the front end input power to the MS1U *Power Modules*. This is available in two package sizes and a number of power ratings. See Section 11, Power Ratings for more detail.

Bias Voltage

A SELV isolated bias (always on) voltage of 5V @ 250mA is provided on J2 pin 2 relative to J2 pin 1 (common) and may be used for miscellaneous control functions. For medical applications, this bias supply voltage has 4000VAC isolation.

Section 10 Power Unit (global) signals AC Fail

AC Fail

AC Mains Fail signal is implemented by an Opto-isolated signal with a maximum sink current of 4mA. During normal operation the transistor is ON. When the input voltage is lost or goes below 80Vac, the opto-transistor is turned OFF at least 5mS before loss of output regulation (at nominal *Power Module* voltage or below)

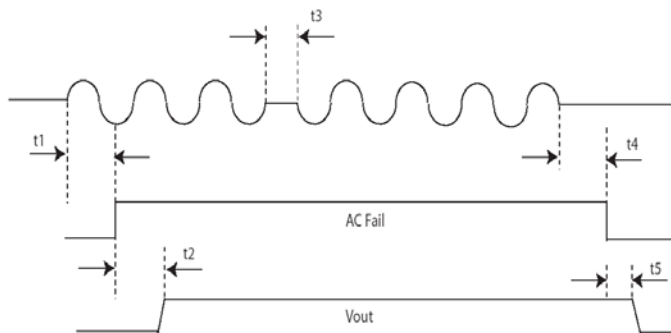

- 80ms < t1 < 100ms
- 80ms < t2 < 150ms
- t3 = 10ms
- t4 > 10ms
- t5 > 5ms

Global Inhibit

A global inhibit function may be implemented via simple contact closure as shown This function inhibits ALL *Power Module* outputs except the auxiliary bias voltage. Global inhibit also shuts down the Power Units fans.

Global Enable A global enable function may be implemented via simple contact closure as shown in the diagram.

Ensure that J2 pin 8 and J2 pin 1 are connected prior to contact closure. This function enables ALL *Power Modules* outputs and the *Power Unit* fans.

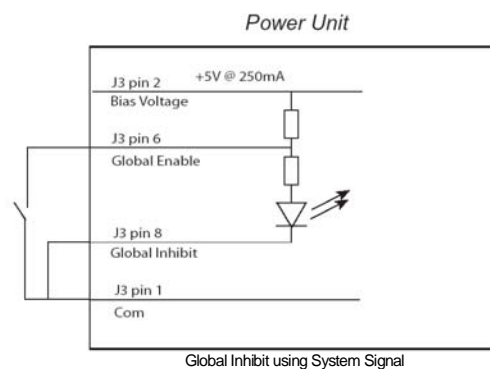
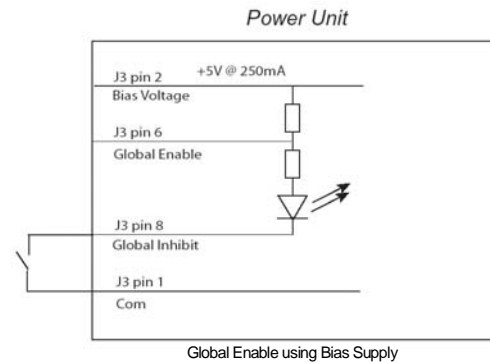

Global Inhibit Using an External Signal

A global inhibit function may be implemented using a signal from the system using the diagram shown. This function inhibits ALL *Power Module* outputs. Global inhibit also shuts down the *Power Unit* fans.

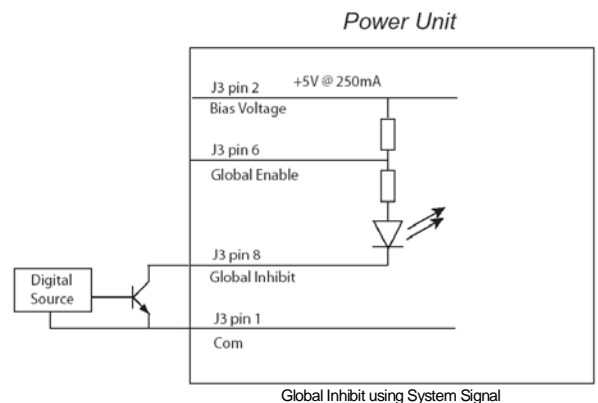

Global Enable Using an External Signal

A global enable function may be implemented using a signal from the system using the diagram shown overleaf. This function enables ALL *Power Module* outputs.

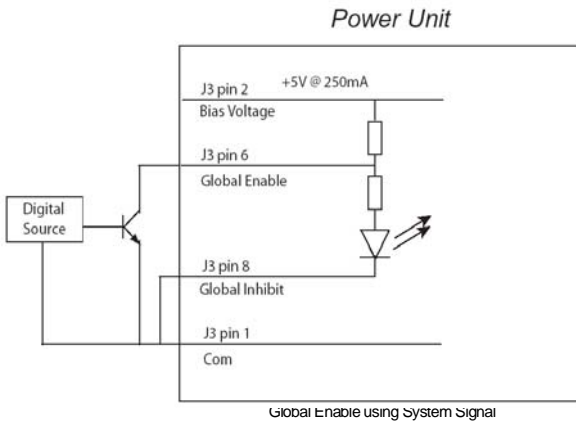

Section 11 Power Unit options

Temperature Alarm (Option 01)

Open collector signal indicating that excessive temperature has been reached due to fan failure or operation beyond ratings. This signal is activated at least 10ms prior to system shutdown.

Fan Fail (Option 01)

Open collector signal indicating that at least one of the Power Unit fans have failed. This does not cause power supply shutdown. The power supply will continue to operate until the 10ms after the Temperature Alarm signal is generated. $t_8 > 10ms$

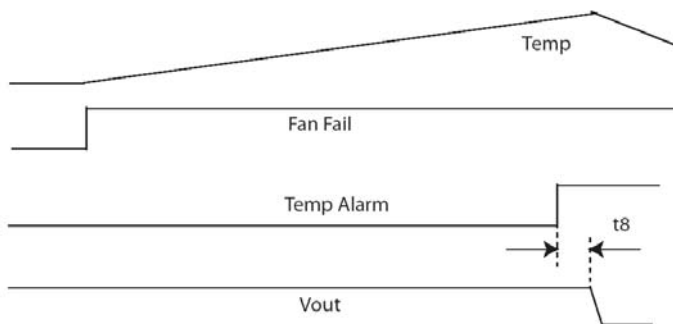

Reverse Fan (Option 02)

The MS1U series is available with reverse air flow direction. This is ideal to expel air from the system and works particularly well with the internal fan cooling built into the overall system.

Reverse Air option is only available on MS1U -6A, 6B, 6C & MM1U-6A, 6B and 6C Power Units.

Section 12 - Power Ratings

When specifying an MS1U series power supply in an application it is necessary to ensure that Power Units and Power Modules are operating within their power output capabilities.

Power Modules are designed to provide maximum output power at the nominal output voltages. The maximum permissible output power that may be drawn from any Power Modules is given in the Power Modules specification table.

The power rating requirement of the Power Unit must always be calculated by summing the Power Modules powers specified

in the application. This sum must not exceed the Power Unit power rating.

Derating at Elevated Temperatures

Power Module and Power Units (except the MS1U6H/6J model family) must be derated for temperature, linearly from 100% of rated power at 50°C to 50% of rated power at 70°C.

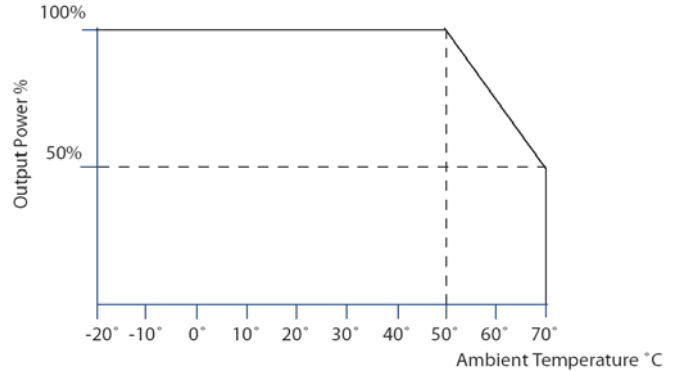

Derating Curve of Output Power versus Ambient Temperature

Derating at Low Input Voltages

Please refer to the specific derating curves for the different MS1U families. MS1U-6A/B/C/D and MM1U-6A/B/C/D 1200watt models must be derated linearly for input operating voltages below 120Vac from 1200watts at 120Vac to 850watts at 85Vac. MS1U-6A/B/C/D and MM1U-6A/B/C/D 1000watt models must be derated linearly for input operating voltages below 120Vac from 1000watts at 120Vac to 850watts at 85Vac.

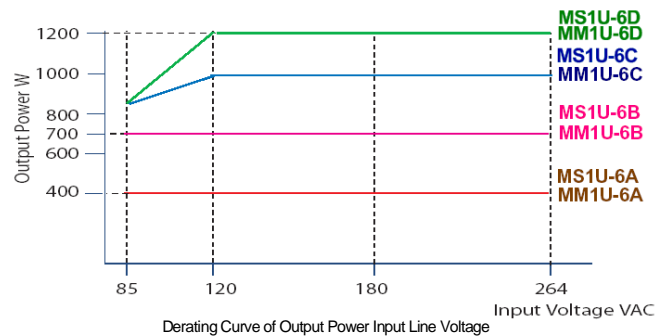

Derating Curve of Output Power Input Line Voltage

MS1U-4C and MM1U-4C 600watt models must be derated linearly for input operating voltages below 180Vac from 600watts at 180Vac to 400watts at 85Vac. MS1U-4M and MM1U-4M 400watt models must be derated linearly for input operating voltages below 120Vac from 400watts at 120Vac to 300watts at 85Vac.

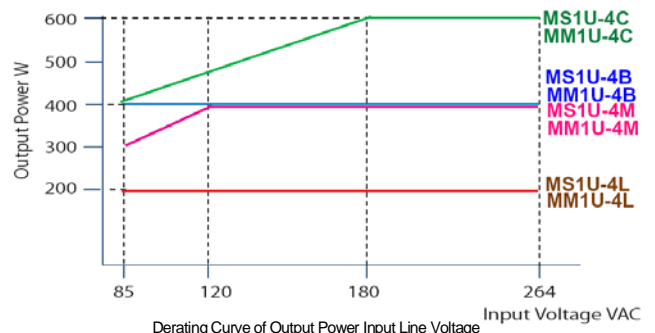

Derating Curve of Output Power Input Line Voltage

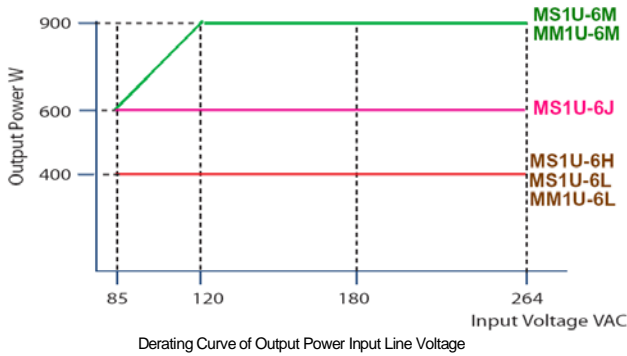

MTBF may be established in two ways, by actual statistics on the hours of operation of a large population of units, or by calculation from a known standard such as MIL-HDBK-217 and its revisions.

Determining MTBF by Calculation

MTBF, when calculated in accordance with MIL-HDBK-217, involves the summation of the failure rates of each individual component at its operating temperature. The failure rate of each component is determined by multiplying a base failure rate for that component by its operating stress level. The result is FPMH, the failure rate per million operating hours for that component.

Then FPMH for an assembly is simply the sum of the individual component FPMH.

$$\text{Total FPMH} = \text{FPMH1} + \text{FPMH2} + \dots + \text{FPMHn}$$

$$\text{MTBF (hours)} = \frac{1,000,000}{\text{FPMH}}$$

In this manner, MTBF can be calculated at any temperature. The MS1U series has been designed to achieve the following failure rates at 25°C and full load.

Power Module	1.0	failures per million hours
Power Unit	0.5	failures per million hours

Calculations based on MIL-HDBK-217 have confirmed these targets.

The figures for the *Power Unit* excludes fans.

Example:
 What is the MTBF of MS1U 4B-4400-00
 MS1U 4B FPMH = 0.5
 Mx4 FPMH = 1.0
 Total FPMH = 2.0

$$\text{MTBF} = 500,000 \text{ hours}$$

Determining MTBF experimentally

MTBF may also be determined from field data. Powerstax verifies its calculated figures by means of extended observation over a large sample of units operating under specific conditions. MS1U units are currently (as of June 1st, 2004) undergoing experimental reliability testing as set out below. The results of this testing will be included in future issues of this document.

Number of Sample Units	50
Power Supply Part Number	MS1U-6D 123458-00
Ambient Temperature	40°C (35 to 45)
Input Voltage:	120VAC
Input Frequency:	50Hz
Output Loading	1000W
Start date of Test	June 1st, 2004
Check date	June 1st, 2005

Total Hours of MTBF Test	438,000 unit hours
Total Number of Failures	3.
	MTBF = 146,000 hours

The derating above refers to 'average power'. Power peaks must be limited to 5 seconds.

Section 13 Reliability

The 'bath-tub' curve shows how the failure rate of a power supply develops over time. It is made up of three separate stages.

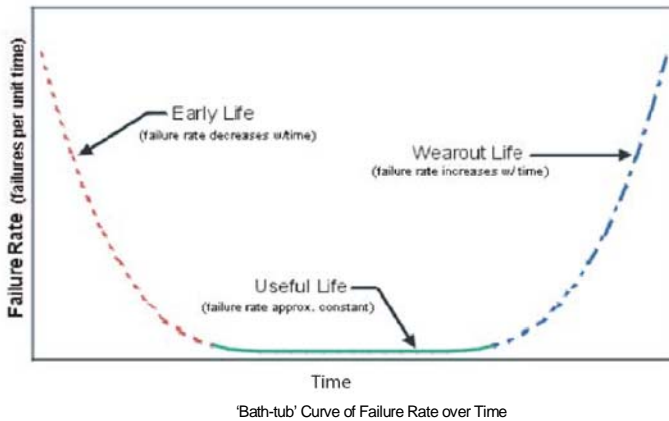

Immediately after production, a relatively high number of units fail due to defective components or production errors. To ensure that these early failures do not happen while in the possession of the user, The factory carries out a burn-in on each unit, designed to ensure that all these early failures are detected at source.

After this period, the power supplies fail very rarely, and the failure rate during this period is fairly constant. The reciprocal of this failure rate is the MTBF (Mean Time Between Failures).

At some time, as the unit approaches its end of life, the first signs of wear appear and failures become more frequent. Generally 'lifetime' is defined as that time where the failure rate increases to five times the statistical rate from the flat portion of the curve.

In summary, the MTBF is a measurement of how many devices fail in a period of time (i.e. a measure of reliability), before signs of wear set in. On the other hand, the lifetime is the time after which the units fail due to wear appearing.

The MTBF may be calculated mathematically as follows:

MTBF = total t / failure , where total is the total number of power supplies operated simultaneously, failure is the number of failures, and t is the observation period.

MTBF and Temperature

Reliability and MTBF are highly dependent on operating temperature. The figures above are given at 40 degrees C. For each 10 degrees decrease, the MTBF increases by a factor of approximately 2.5. Conversely, however, for each 10 degrees increase, the MTBF reduces by a similar factor. Therefore, when comparing manufacturer's quoted MTBF figures, look at the temperature information provided.

Section 14 Safety Approvals

Low Voltage Directive (LVD) 73/23/EEC

The LVD applies to equipment with an AC input voltage of between 50V and 1000V or a DC input voltage between 75V and 1500V. The MS1U series is CE marked to show compliance with the LVD.

The relevant European Standard for MS1U-6A/B/C/D and MS1U-4A/B/C models is EN60950 (Information Technology).

The relevant European Standard for MM1U-6A/B/C/D and MM1U-4A/B/C medical models is EN60601-1 (Medical Devices Directive).

With appropriate packaging, the MS1U can also meet the requirements of EN61010-1 for industrial scientific measuring equipment and process control.

The MS1U-6A/B/C/D/H/J/L/M and MS1U-4A/B/C/D/H/J/L models are designed to comply with the requirements of IEC950, EN60950, UL1950, CSA 22.2 No. 234 and IEC 1010, when correctly installed in a limited access environment.

The MM1U-6A/B/C/D/H/J/L/M and MM1U-4A/B/C/D/H/J/L models are designed to comply with the requirements of IEC601-1, EN60601-1, UL2601-1 and CSA601-1, for non-patient connect applications.

Power Modules Mx2, Mx3, Mx4 and Mx5 are capable of providing hazardous energy levels (>240 VA). Equipment manufacturers must provide adequate protection to service personnel.

Environmental Parameters

The MS1U series is designed for the following parameters:

- Material Group IIIb, Pollution Degree 2
- Installation Category 2
- Class I
- Indoor use (installed, accessible to Service Engineers only).
- Altitude: -155 metres to +3050 metres from sea level.
- Humidity: 5 to 95% non-condensing.
- Operating temperature -20°C to 50°C
- Derate at 2.5%/°C from 50°C to 70°C.

Approval Limitations

Use in North America

When this product is used on 180 to 253 Volts AC mains with no neutral, connect the two live wires to L (live) and N (neutral) terminals on the input connector.

Standard

Creepage Distances MS1U-6A/B/C/D, MS1U-4A/B/C models
 Primary mains circuits to earth: 2.5mm spacing
 Primary mains circuits to secondary: 5mm spacing

Dielectric strength MS1U-6A/B/C/D, MS1U-4A/B/C models

Primary mains circuits to chassis: 1500VAC
 Primary mains circuits to secondary: 3000VAC

Medical

Creepage Distances MM1U-6A/B/C/D, MM1U-4A/B/C models
 Primary mains circuits to earth: 4mm spacing
 Primary mains circuits to secondary: 8mm spacing

Dielectric strength MM1U-6A/B/C/D, MM1U-4A/B/C models

Primary mains circuits to chassis: 1500VAC
 Primary mains circuits to secondary: 4000VAC

The primary to secondary test is not possible with modules fitted to the unit, as damage to the EMI capacitors will occur.

Output Isolation

Outputs are each isolated 500V DC to each other and 500 V DC to chassis.

Section 15 EMC

EMC Directive 89/336/EEC

Component Power Supplies such as the MS1U series are not covered by the EMC directive. It is not possible for any power supply manufacturer to guarantee conformity of the final product to the EMC directive, since performance is critically dependent on the final system configuration.

System compliance with the EMC directive is facilitated by MS1U compliance with several of the requirements as outlined in the following paragraphs. Although the MS1U product series meet these requirements, the CE mark does not cover this area.

EMISSIONS

Power Factor (Harmonic) Correction

The MS1U series incorporates active power factor correction and therefore meets the requirements of EN61000-3-2, as demonstrated by the test results set out below.

EN61000-3-2 MS Harmonic Currents (typical)

Results taken at 640W Output Power

	115V AC	In 230V AC In
Harmonic 1	6.420A 100%	3.030A 100%
Harmonic 3	0.10A 1.6%	0.128A 4.2%
Harmonic 5	0.11A 1.7%	0.106A 3.5%
Harmonic 7	0.042A 0.7%	0.014A 0.5%
Harmonic 9	0.067A 1.0%	0.062A 2.0%
Harmonic 11	0.052A 0.8%	0.078A 3.5%
Harmonic 13	0.044A 0.7%	0.064A 2.1%
Efficiency	87%	91%

EN61000-3-3 Flicker & Voltage Fluctuation Limits

MS1U power supplies meet the requirements of the limits on voltage fluctuations and flicker in low voltage supply systems.

EN55022 Class B Conducted Emissions

MS1U Series
Under appropriate test conditions, the MS1U series meets the requirements of EN55022 Class B, without the need for external filtering.

IMMUNITY

The MS1U series has been designed to meet, and tested to, the immunity specifications outlined below:

EN61000-4-2 Electrostatic Discharge Immunity

Level 4
8kV Air discharge applied to Enclosure
6kV Contact with Enclosure

EN61000-4-3 Radiated Electromagnetic Field

Immunity
Level 3
10Volts/metre 26 to 1000Mhz applied to Enclosure

EN61000-4-4 Fast Transients-Burst Immunity

(Common Mode)
Level 4
4kV, 2.5kHz Repetition, Burst period 300ms

EN61000-4-5 Input Surge Immunity

Level 3
+/-2kV Common Mode 1.2/50 S (Voltage); 8/20uS (Current)
+/- 1kV Differential Mode 1.2/50 S (Voltage) 8/20 S (Current)

EN61000-4-6 Conducted RFI

10 V/m
EN61000-4-11 Voltage Dips
95% drop 10ms
Measured according to EN55024

Guidelines for Optimum EMC Performance

The MS1U series is designed to comply with European Normative limited (EN) for conducted and radiated when correctly installed in a system. See performance levels attained above. However, power supply compliance with these limits is not a guarantee of system compliance. System EMC performance can be impacted by a number and combination items. Design consideration such as PCB layout and tracking, cabling arrangements and orientation of the power supply amongst others all directly contribute to the EMC performance of a system.

Cabling arrangements and PCB tracking layouts are the greatest contributing factor to system EMC performance. It is important that PCB tracks and power cables are arranged to minimise current carrying loops that can radiate, and to minimise loops that could have noise currents induced into them. All cables and PCB tracks should be treated as radiation sources and antennae and every effort should be made to minimise their interaction

a. Keep all cable lengths as short as possible.

- b. Minimise the area of power carrying loops to minimise radiation, by using twisted pairs of power cables with the maximum twist possible.
- c. Run PCB power tracks back to back.
- d. Minimise noise current induced in signal carrying lines, by twisted pairs for sense cables with the maximum twist possible.
- e. Do not combine power and sense cables in the same harness
- e. Ensure good system grounding. System Earth should be a "starpoint". Input earth of the equipment should be directed to the "starpoint" as soon as possible. The power supply earth should be connected directly to the "starpoint". All other earths should go to the 'starpoint"

Section 16 Connectors

Below are pinout connections and diagrams of the MS1U power and signal connectors.

Output Connector Pinout

Pin	J3 (Type B)	J3 (Type A)
1	-Vout	-V2
2	+Vout	+V2
3		-V1
4		+V1

J4 Mating Connectors:
M4 Screw Terminals
Type B: Phoenix p/n MSTB2.5/4-ST-5.08

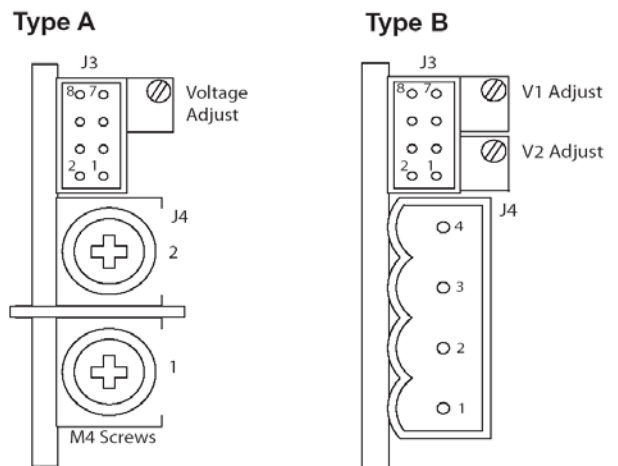

Output Connector Pinout

Pin	J3 (Type B)	J3 (Type A)
1	+Sense	common
2	-Sense	+5V bias
3	V trim	
4	I trim	ac fail
5	+inhibit/enable	fan fail*
6	-inhibit/enable	global enable
7	+power good	temp alarm*
8	-power good	global inhibit

J3 powerMod Signals Mating Connector:
Housing: Molex p/n 51110 or equivalent
Crimp Terminal: Molex p/n 50394

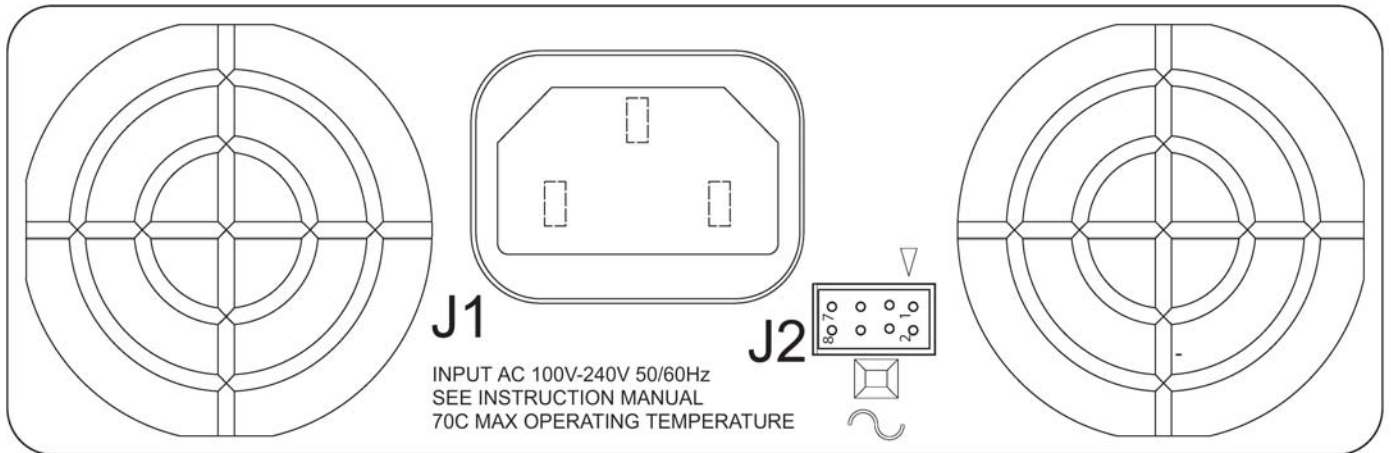

Input Connector and Signals Pinout J2 powerPac

Pin	J1	J2 (Power Unit)
1	Line	common
2	Neutral	+5V bias
3	Earth	
4		ac fail
5		fan fail*
6		global enable
7		temp alarm*
8		global inhibit

* Option 01.

J1 Mating Connector:

IEC320 type female plug rated 13A

J2 Signals Mating Connector:

Housing: Molex p/n 51110 or equivalent

Crimp Terminal: Molex p/n 50394

Section 17 Mechanical Specifications

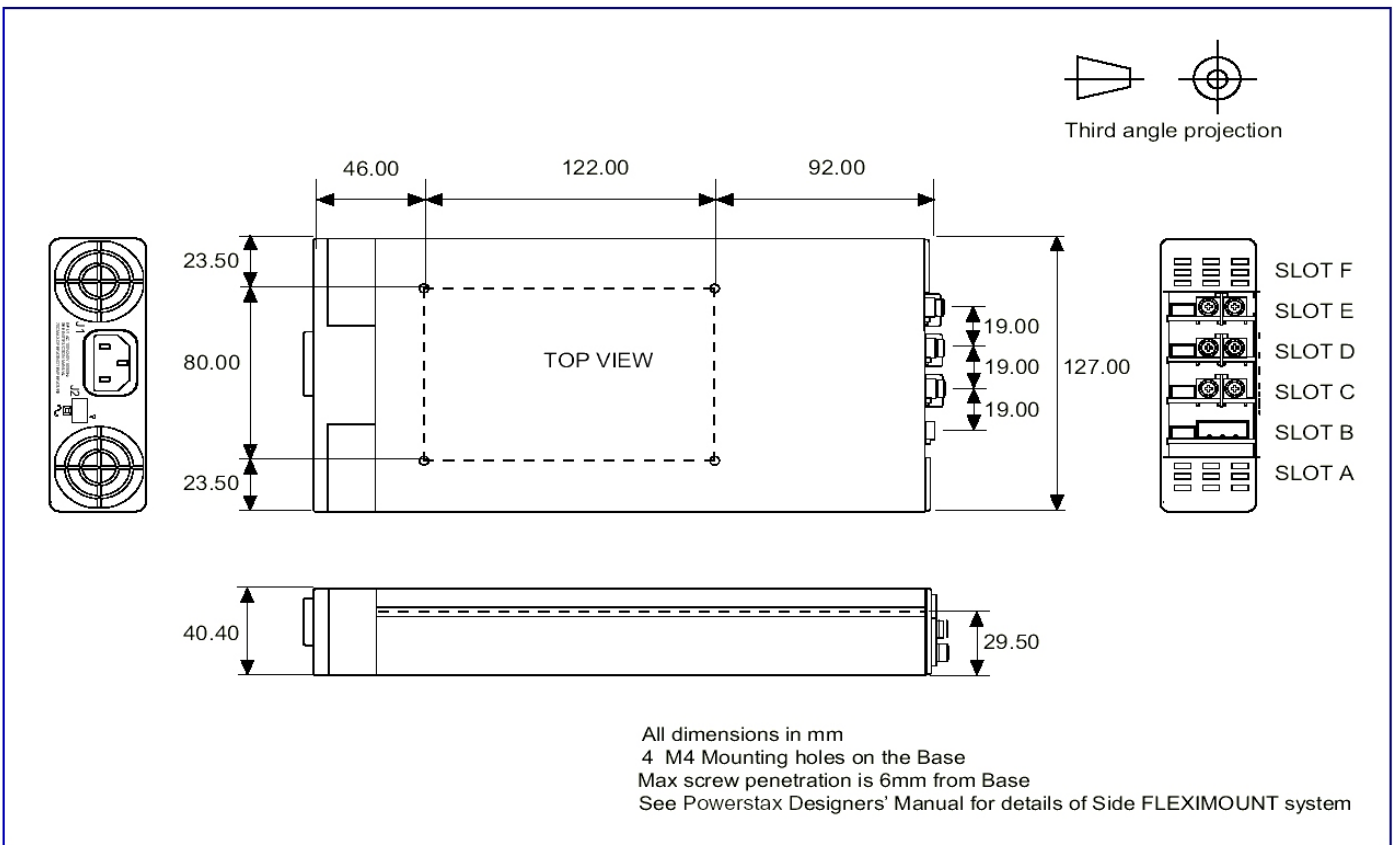
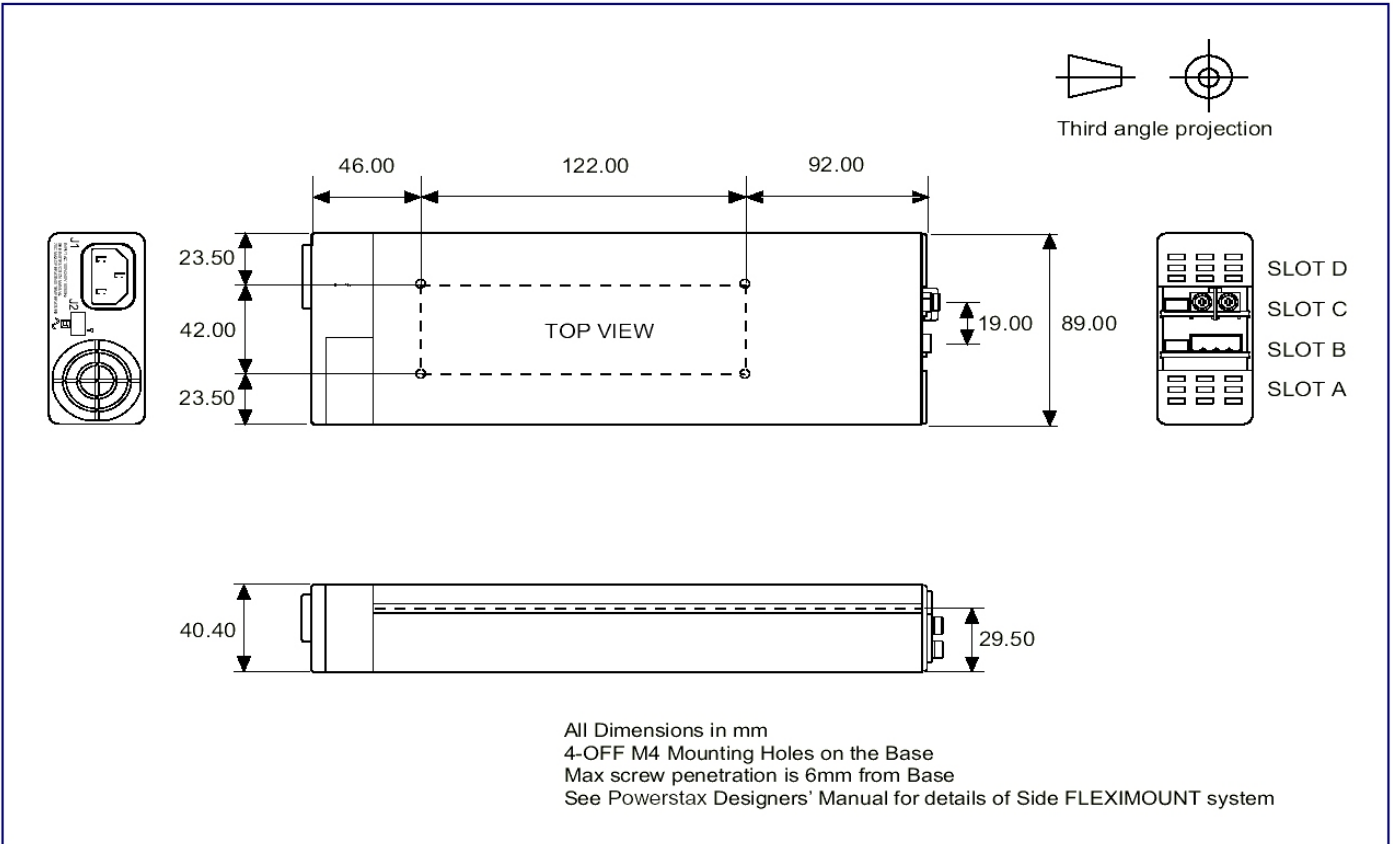

Information & specifications contained in this data sheet are believed to be correct at the time of publication. However, Powerstax accepts no responsibility for consequences arising from printing errors or inaccuracies. Specifications are subject to change without notice