

Input Ranges :
9-75 VDC

Output Voltage:
Single Output
12V - 48V

Dual Output
+5.0V/+12V
+5.0V/+15V

Triple Output
+5.0V/±12V,
+5.0V/±15V,

Output Power:
100 - 300 W



FEATURES

General:

- Small footprint : 3.0" x 3.0"
- High output power : to 300 watts
- Wide input range : 10-75Vdc
- Open frame or encapsulated
- Integral PCB transformer
- High conversion efficiency to 93%
- Line regulation to ±0.1%
- Load regulation to ±0.5%
- Fixed operating frequency

Protection:

- Output over-voltage protection
- Output over-load protection
- Hiccup mode short circuit protection
- Over-temperature protection
- Input under-voltage lock-out
- Input over-voltage shut-down

Control:

- Enable (On/Off) Control
- Output Voltage Trim

Isolation:

- Isolation Voltage > 500V

MH series is a family of high power density, high efficiency, and high reliability DC-DC Converters. It provides up to 300W output in a 3.0" x 3.0" footprint. The wide input range (2:1 & 3:1) is ideal for battery or unregulated input applications. Integral PCB transformer / inductor is used for all models in this series. This new design technique has greatly improved the magnetic coupling, reduced switching spike and provided performance consistency. It also streamlines the production process by completely eliminating the hand-wind magnetic assembly process from production lines.

MH series provides the most extensive protection to safeguard both the power converter and the load. It includes output over-voltage protection, over-current protection, hiccup mode indefinite short circuit protection, under-voltage lockout and over-temperature protection. Over-current inception point is set at about 115% of rated load. Hiccup mode cycles for 28mSec periods with 3mSec on and 25mSec off. Over-temperature shutdown, activated at +105°C of board temperature, will recover when the temperature falls below +95°C.

MH series features low output noise, very tight line and load regulation, and high efficiency. No external capacitor requirement for normal operation.

TABLE OF CONTENTS :

General Specifications	2
Single Output	4
Dual Output	10
Triple Output.....	14

1. Absolute Maximum Ratings

Stresses in excess of the absolute maximum ratings can cause performance degradation, adversely effect longterm reliability, and cause permanent damage to the device.

Parameter	Voltage Range Designator / Description	Min	Max	Units
Input Voltage				
Continuous	12	-0.3	22	Vdc
	24	-0.3	38	Vdc
	48	-0.3	78	Vdc
	30	-0.3	32	Vdc
	60	-0.3	62	Vdc
Transient (100mSec.)	12	-0.3	24	Vdc
	24	-0.3	40	Vdc
	48	-0.3	80	Vdc
	30	-0.3	34	Vdc
	60	-0.3	64	Vdc
Operating Temperature	All models, base plate temperature	-40	+105	°C
Storage Temperature	Ambient	-55	+125	°C
Isolation Voltage	Input to Output		+2000	Vdc

2. Input Specifications

Parameter	Conditions / Description	Min	Nom	Max	Units
Input Voltage					
Voltage Range (Continuous)	12	10	12	20	Vdc
	24	18	24	36	Vdc
	48	36	48	75	Vdc
	30	10	24	32	Vdc
	60	20	48	60	Vdc
Under-Voltage Lockout (UVLO)					
Turn-On Threshold (Ramping Up)	12		9.7		Vdc
	24		17		Vdc
	48		35		Vdc
	30		9.7		Vdc
	60		17		Vdc
Turn-Off Threshold (Ramping Down)	12		9.7		Vdc
	24		16		Vdc
	48		33		Vdc
	30		9.2		Vdc
	60		16		Vdc

3. Enable (On-Off Control)

Parameter	Conditions / Description	Min	Nom	Max	Units
Enable Pin					
Open Circuit Voltage			10		Vdc
Source Current				1	mA
Positive Logic Standard					
On-Control	Logic High or Floating	2.5		10	Vdc
Off-Control		-0.5		1.8	Vdc
Negative Logic Optional (Please add Suffix N)					
On-Control		-0.5		1.8	Vdc
Off-Control	Logic High or Floating	2.5		10	Vdc

4. Output Specifications

Parameter	Conditions / Description	Min	Nom	Max	Units
Voltage Accuracy	Please see table				%
Output Current	Please see table				Adc
Start-Up Time			150		mSec.
Output Trim				±5	%Vout
Over Voltage Protection				120	%Vdc
Line Regulation				±0.1	%Vout
Load Regulation				±0.5	%Vout
Transient Response	50% ± 25% step load change		400		µSec.
Ripple & Noise	Please see table				mVp-p
Switching Frequency			250		KHz

5. Output Trim

Parameter	Conditions / Description	Min	Nom	Max	Units
Negative Trim	Standard				
Trim Up	Trim Pin to (-)Vout			5	%Vdc
Trim Down	Trim Pin to (+)Vout	5			%Vdc
Positive Trim	Not Available				

*Trim pin can be left floating if not used

6. Environmental and Mechanical Specifications

Parameter	Conditions / Description	Min	Nom	Max	Units
Operating Temperature	PCB Temperature				
Standard		-25		+105	°C
Extended	Optional - (Please add Suffix C)	-55		+105	°C
Storage Temperature		-55		+125	°C
Temperature Coefficient				±0.02	%/°C
Shock	Halfsine wave, 3 axes	50			g
Sinusoidal Vibration	GR-63-CORE, Section 5.4.2	1			g
Humidity	Relative Humidity, Non-Condensing			95	%R.H.
Weight					
PC Board Mount			6.4(180)		Oz(g)
Chassis Mount			7.7(218)		Oz(g)
MTBF (calculated)	Bellcore TR-NWT-000332 method 1 - parts count	1			MHrs

7. Isolation Specifications

Parameter	Conditions / Description	Min	Nom	Max	Units
Isolation Voltage	Input to Output	500			Vdc
	I/O to Case	500			Vdc
Isolation Resistance	Input to Output	10			MΩ
Isolation Capacitance	Input to Output		3		nF

8. Protections

Parameter	Conditions / Description	Min	Nom	Max	Units
Over-Load Protection					
Type	Current-Mode, Pulse by Pulse Current Limit				
Threshold	% Rated Load		120		%
Short-Circuit Protection					
Type	Hiccup Mode, Non-Latching, Auto-Recovery				
Threshold	Short-Circuit Resistance			65	mΩ
Over-Temperature Protection					
Type	Non-Latching, Auto-Recovery				
Threshold	PCB Temperature		105		°C
Hysteresis			15		°C
Over-Voltage Protection					
Type	Auxiliary Feedback Loop Control				
Set-Point				120	%Vout

BLOCK DIAGRAM

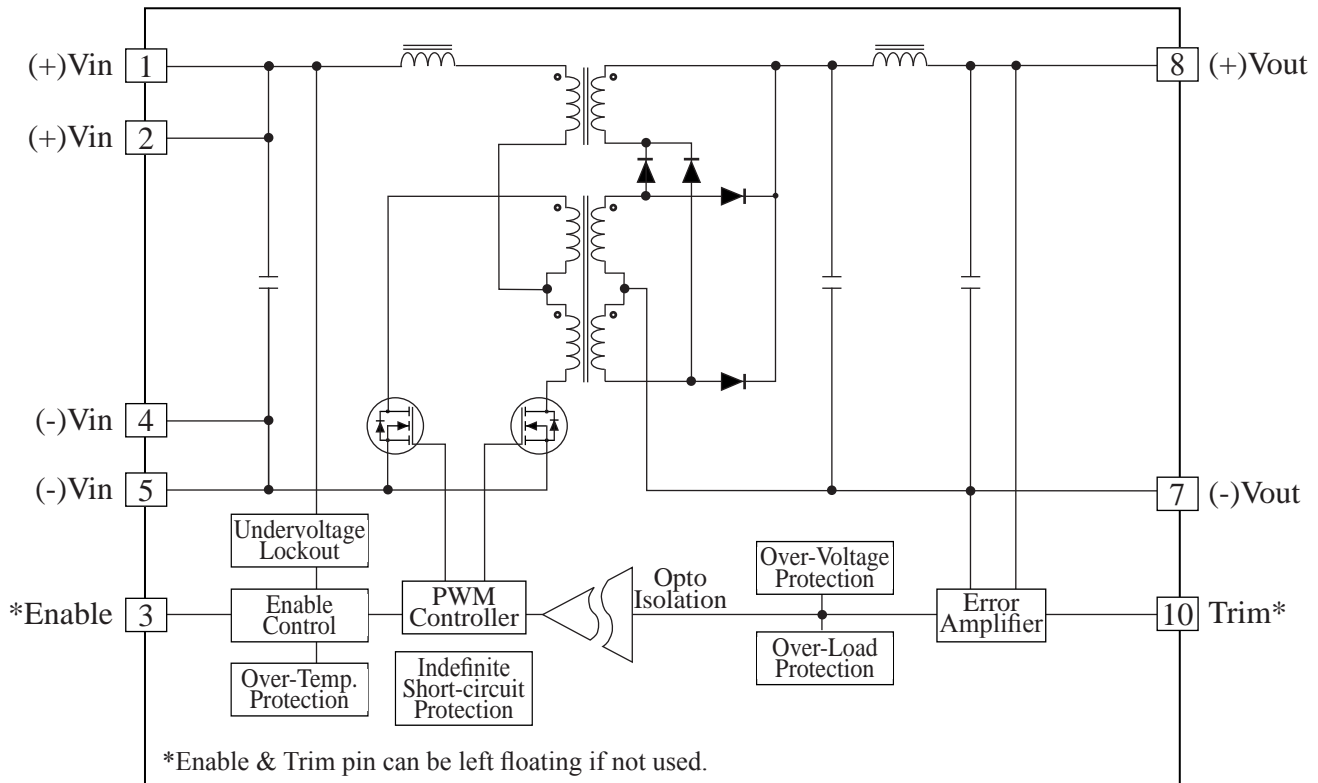

Product Numbering System & Selection Guide

MH	150	S	60	12	TS
Series No.	Output Power	No Output	Input Voltage Range	Output Voltage	Options
MH	100 : 100W	S : Single	12 : 10-20V	12 : 12V	C : Extended Temp.
	150 : 150W		24 : 18-36V	15 : 15V	MC : Encapsulated
	200 : 200W*		48 : 36-75V	24 : 24V	N : Negative Enable
	300 : 300W*		30 : 10-32V	28 : 28V	TS : Chassis Mount
			60 : 20-60V	48 : 48V	

* Available for 24V, 28V & 48V output only.

Open Frame (Standard)

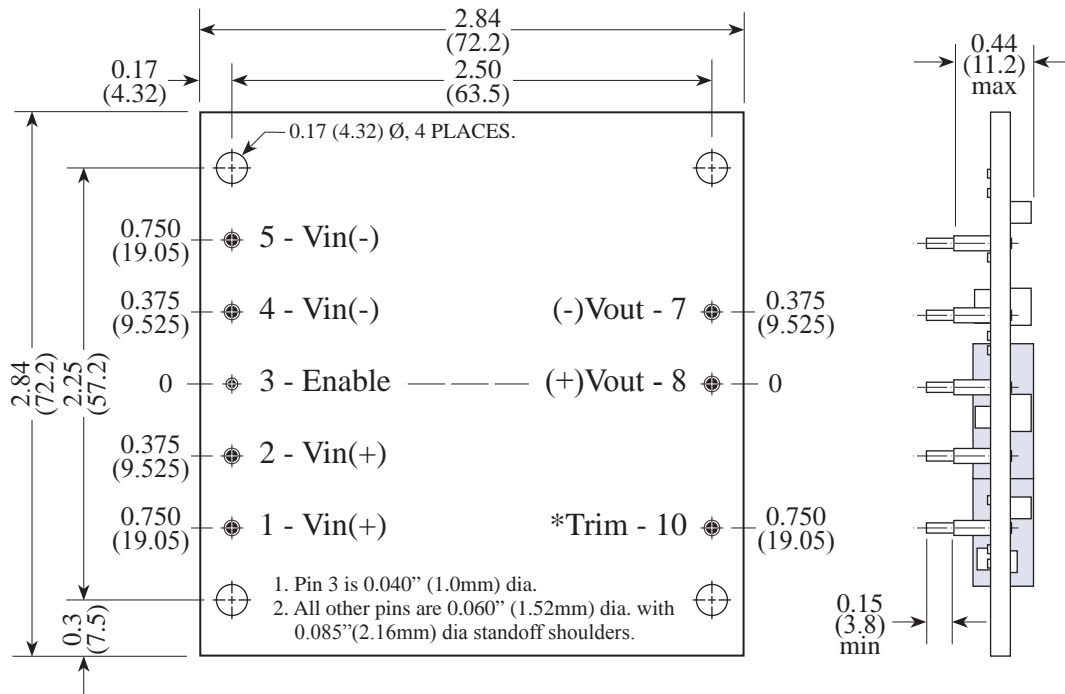

Encapsulated (Optional, MC Suffix)

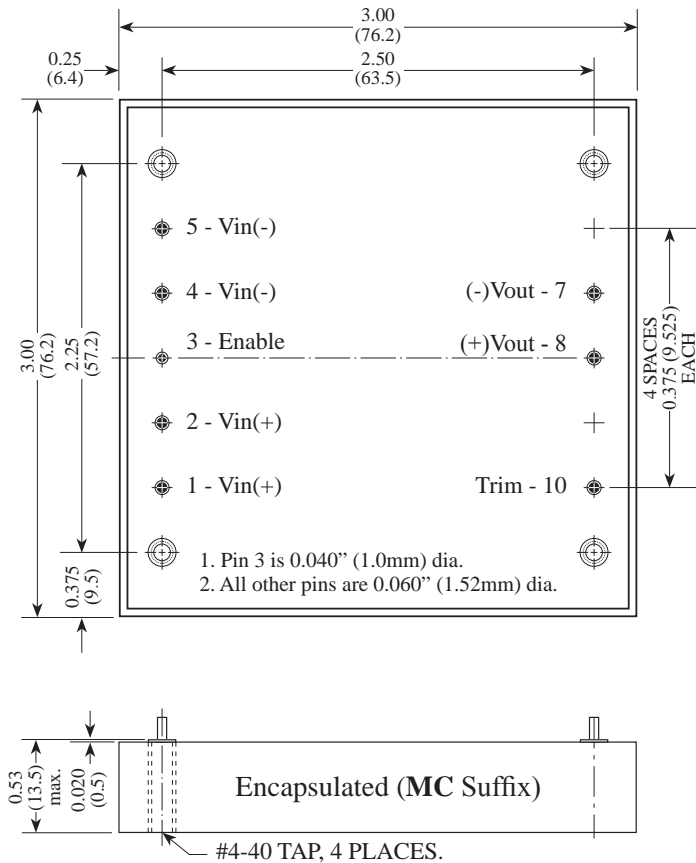

Chassis Mount (Optional, TS Suffix)

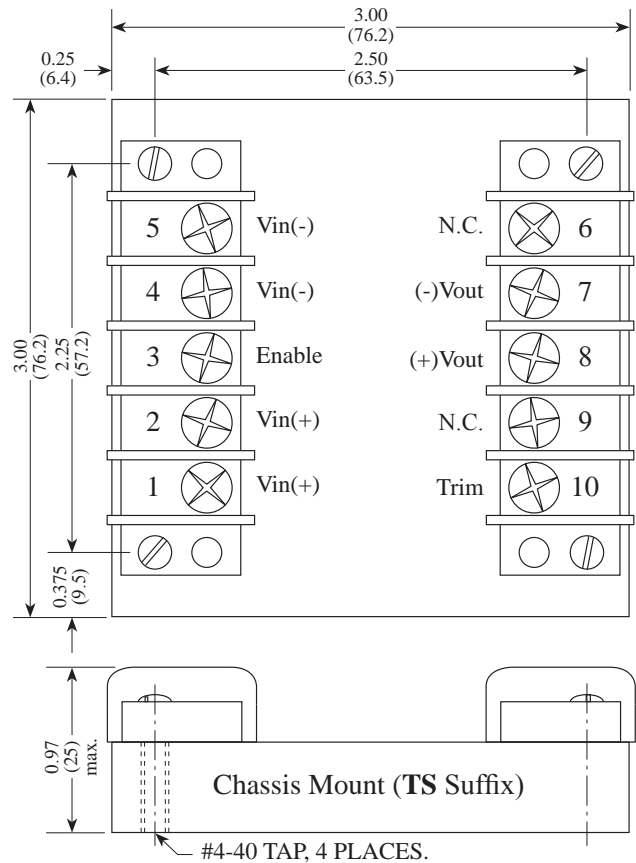

Range Designator (Range)	INPUT		Power (Watts)	OUTPUT								Short Circuit Protection	Over Temp. Shutdown /Recover	EFF. (typ.)	MODEL NO.					
	UVL (On/Off)	OVP (Max)		Voltage (V)			Current (A)		Ripple & Noise		OVP									
				Set Point	Min.*	Max.*	Min.	Max.	Peak-Peak	R.M.S.										
12 (10 - 20)	9.8V/ 9.5V	22V	100	12V	11.8	12.2	0.8	8.4A	80mV	15mV	15V	Hiccup Mode Indefinite	+105/+95°C	88%	MH100S1212					
				15V	14.8	15.2	0.6	6.7A	100mV	20mV	18V			88%	MH100S1215					
				24V	23.8	24.2	0.4	4.2A	150mV	30mV	28V			90%	MH100S1224					
				28V	27.5	28.5	0.3	3.6A	180mV	40mV	33V			90%	MH100S1228					
				48V	47.0	49.0	0.2	2.1A	300mV	60mV	57V			90%	MH100S1248					
				12V	11.8	12.2	1.2	12.5A	80mV	15mV	15V			+105/+95°C	88%	MH150S1212				
			15V	14.8	15.2	1.0	10.0A	100mV	20mV	18V	88%		MH150S1215							
			24V	23.8	24.2	0.6	6.3A	150mV	30mV	28V	90%		MH150S1224							
			28V	27.5	28.5	0.5	5.4A	180mV	40mV	33V	90%		MH150S1228							
			48V	47.0	49.0	0.3	3.2A	300mV	60mV	57V	90%		MH150S1248							
			15V	14.8	15.2	1.3	13.4A	100mV	20mV	18V	+100/+90°C		89%		MH200S1215					
			24V	23.8	24.2	0.8	8.4A	150mV	30mV	28V			90%	MH200S1224						
			28V	27.5	28.5	0.7	7.2A	180mV	40mV	33V			90%	MH200S1228						
			48V	47.0	49.0	0.4	4.2A	300mV	60mV	57V			90%	MH200S1248						
			24V	23.8	24.2	1.2	12.5A	150mV	30mV	28V			+95/+85°C	88%	MH300S1224					
			28V	27.5	28.5	1.0	10.8A	180mV	40mV	33V				88%	MH300S1228					
			48V	47.0	49.0	0.6	6.3A	300mV	60mV	57V	88%			MH300S1248						
			30 (10 - 32)	9.8V/ 9.5V	34V	100	12V	11.8	12.2	0.8	8.4A			80mV	15mV	15V	Hiccup Mode Indefinite	+105/+95°C	86%	MH100S3012
							15V	14.8	15.2	0.6	6.7A			100mV	20mV	18V			86%	MH100S3015
							24V	23.8	24.2	0.4	4.2A			150mV	30mV	28V			88%	MH100S3024
							28V	27.5	28.5	0.3	3.6A		180mV	40mV	33V	88%			MH100S3028	
							48V	47.0	49.0	0.2	2.1A		300mV	60mV	57V	88%			MH100S3048	
							12V	11.8	12.2	1.2	12.5A		80mV	15mV	15V	+105/+95°C			86%	MH150S3012
						15V	14.8	15.2	1.0	10.0A	100mV		20mV	18V	86%			MH150S3015		
24V	23.8	24.2				0.6	6.3A	150mV	30mV	28V	88%	MH150S3024								
28V	27.5	28.5				0.5	5.4A	180mV	40mV	33V	88%	MH150S3028								
48V	47.0	49.0				0.3	3.2A	300mV	60mV	57V	88%	MH150S3048								
15V	14.8	15.2				1.3	13.4A	100mV	20mV	18V	+100/+90°C	87%	MH200S3015							
24V	23.8	24.2				0.8	8.4A	150mV	30mV	28V		88%	MH200S3024							
28V	27.5	28.5				0.7	7.2A	180mV	40mV	33V		88%	MH200S3028							
48V	47.0	49.0				0.4	4.2A	300mV	60mV	57V		88%	MH200S3048							
24V	23.8	24.2				1.2	12.5A	150mV	30mV	28V		+95/+85°C	86%	MH300S3024						
28V	27.5	28.5				1.0	10.8A	180mV	40mV	33V			86%	MH300S3028						
48V	47.0	49.0				0.6	6.3A	300mV	60mV	57V	86%		MH300S3048							
24 (18 - 36)	17.7V/ 17.5V	38V				100	12V	11.8	12.2	0.8	8.4A		80mV	15mV	15V	Hiccup Mode Indefinite		+105/+95°C	90%	MH100S2412
							15V	14.8	15.2	0.6	6.7A		100mV	20mV	18V				90%	MH100S2415
							24V	23.8	24.2	0.4	4.2A		150mV	30mV	28V				92%	MH100S2424
							28V	27.5	28.5	0.3	3.6A	180mV	40mV	33V	92%				MH100S2428	
							48V	47.0	49.0	0.2	2.1A	300mV	60mV	57V	92%				MH100S2448	
							12V	11.8	12.2	1.2	12.5A	80mV	15mV	15V	+105/+95°C				90%	MH150S2412
						15V	14.8	15.2	1.0	10.0A	100mV	20mV	18V	90%				MH150S2415		
			24V	23.8	24.2	0.6	6.3A	150mV	30mV	28V	92%	MH150S2424								
			28V	27.5	28.5	0.5	5.4A	180mV	40mV	33V	92%	MH150S2428								
			48V	47.0	49.0	0.3	3.2A	300mV	60mV	57V	92%	MH150S2448								
			15V	14.8	15.2	1.3	13.4A	100mV	20mV	18V	+100/+90°C	90%	MH200S2415							
			24V	23.8	24.2	0.8	8.4A	150mV	30mV	28V		92%	MH200S2424							
			28V	27.5	28.5	0.7	7.2A	180mV	40mV	33V		92%	MH200S2428							
			48V	47.0	49.0	0.4	4.2A	300mV	60mV	57V		92%	MH200S2448							
			24V	23.8	24.2	1.2	12.5A	150mV	30mV	28V		+95/+85°C	90%	MH300S2424						
			28V	27.5	28.5	1.0	10.8A	180mV	40mV	33V			90%	MH300S2428						
			48V	47.0	49.0	0.6	6.3A	300mV	60mV	57V	90%		MH300S2448							

* Combined Line & Load Regulation (Low Line to High Line & Min. Load to Full Load)

(Continued on Next Page)

(Continued from Previous Page)

Range Designator (Range)	INPUT			OUTPUT								Short Circuit Protection	Over Temp. Shutdown /Recover	EFF. (typ.)	MODEL NO.						
	UVL (On/Off)	OVP (Max)	Power (Watts)	Voltage (V)			Current (A)		Ripple & Noise		OVP										
				Set Point	Min.*	Max.*	Min.	Max.	Peak-Peak	R.M.S.											
48 (36-75)	35V/34V	75V	100	12V	11.8	12.2	0.8	8.4	80mV	15mV	15V	Hiccup Mode Indefinite	+105/+95°C	90%	MH100S4812						
				15V	14.8	15.2	0.6	6.7	100mV	20mV	18V			90%	MH100S4815						
				24V	23.8	24.2	0.4	4.2	150mV	30mV	28V			92%	MH100S4824						
				28V	27.5	28.5	0.3	3.6	180mV	40mV	33V			92%	MH100S4828						
				48V	47.0	49.0	0.2	2.1	300mV	60mV	57V			92%	MH100S4848						
				150	12V	11.8	12.2	1.2	12.5	80mV	15mV			15V	+105/+95°C	90%	MH150S4812				
					15V	14.8	15.2	1.0	10.0	100mV	20mV			18V		90%	MH150S4815				
					24V	23.8	24.2	0.6	6.3	150mV	30mV			28V		92%	MH150S4824				
					28V	27.5	28.5	0.5	5.4	180mV	40mV			33V		92%	MH150S4828				
				200	48V	47.0	49.0	0.3	3.2	300mV	60mV			57V	+100/+90°C	93%	MH150S4848				
					15V	14.8	15.2	1.3	13.4	100mV	20mV			18V		90%	MH200S4815				
					24V	23.8	24.2	0.8	8.4	150mV	30mV			28V		92%	MH200S4824				
			28V		27.5	28.5	0.7	7.2	180mV	40mV	33V		92%	MH200S4828							
			300	48V	47.0	49.0	0.4	4.2	300mV	60mV	57V		+95/+85°C	92%	MH200S4848						
				24V	23.8	24.2	1.2	12.5	150mV	30mV	28V			90%	MH300S4824						
				28V	27.5	28.5	1.0	10.8	180mV	40mV	33V			90%	MH300S4828						
				48V	47.0	49.0	0.6	6.3	300mV	60mV	57V			90%	MH300S4848						
			60 (20-60)	17.7V/ 17.5V	62V	100	12V	11.8	12.2	0.8	8.4		80mV	15mV	15V	Hiccup Mode Indefinite	+105/+95°C	88%	MH100S6012		
							15V	14.8	15.2	0.6	6.7		100mV	20mV	18V			88%	MH100S6015		
							24V	23.8	24.2	0.4	4.2		150mV	30mV	28V			90%	MH100S6024		
							28V	27.5	28.5	0.3	3.6		180mV	40mV	33V			90%	MH100S6028		
							48V	47.0	49.0	0.2	2.1		300mV	60mV	57V			90%	MH100S6048		
							150	12V	11.8	12.2	1.2		12.5	80mV	15mV			15V	+105/+95°C	88%	MH150S6012
								15V	14.8	15.2	1.0		10.0	100mV	20mV			18V		88%	MH150S6015
24V	23.8	24.2						0.6	6.3	150mV	30mV	28V	90%	MH150S6024							
28V	27.5	28.5						0.5	5.4	180mV	40mV	33V	90%	MH150S6028							
200	48V	47.0					49.0	0.3	3.2	300mV	60mV	57V	+100/+90°C	90%	MH150S6048						
	15V	14.8					15.2	1.3	13.4	100mV	20mV	18V		88%	MH200S6015						
	24V	23.8					24.2	0.8	8.4	150mV	30mV	28V		90%	MH200S6024						
	28V	27.5				28.5	0.7	7.2	180mV	40mV	33V	90%		MH200S6028							
300	48V	47.0				49.0	0.4	4.2	300mV	60mV	57V	+95/+85°C	90%	MH200S6048							
	24V	23.8				24.2	1.2	12.5	150mV	30mV	28V		90%	MH300S6024							
	28V	27.5				28.5	1.0	10.8	180mV	40mV	33V		90%	MH300S6028							
	48V	47.0				49.0	0.6	6.3	300mV	60mV	57V		90%	MH300S6048							

* Combined Line & Load Regulation (Low Line to High Line & Min. Load to Full Load)

Efficiency Curves

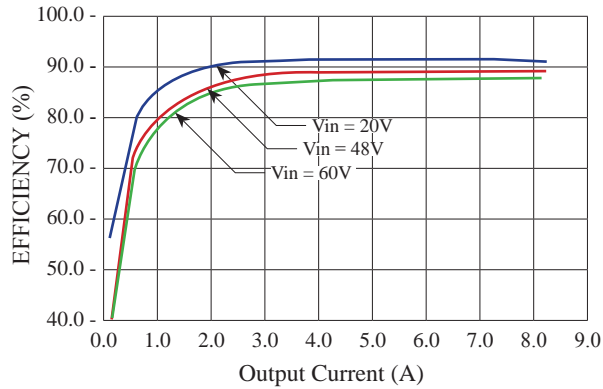

MH100S48W12

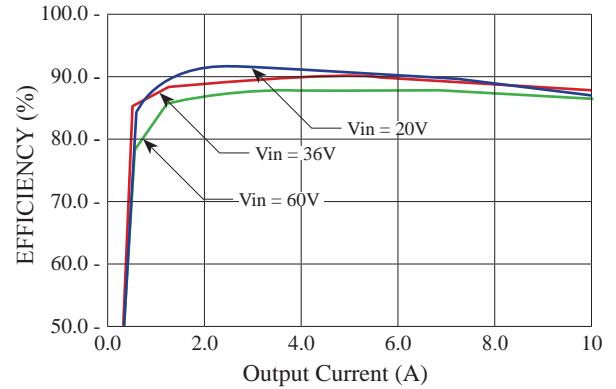

MH300S6030

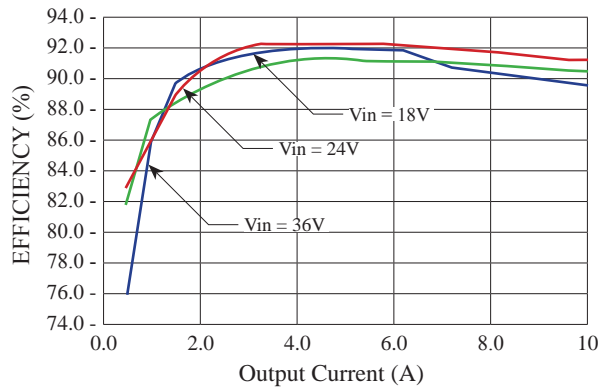

MH150S2415

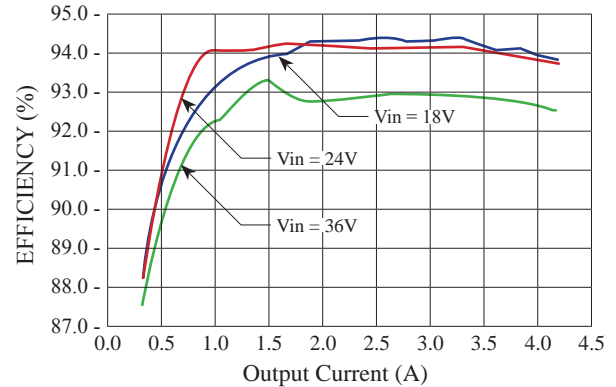

MH200S2448

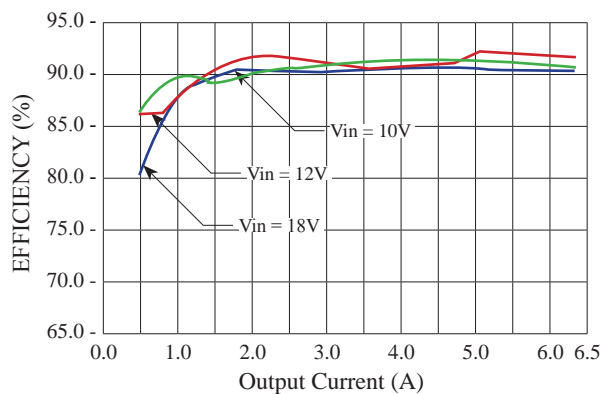

MH150S1224

NOTE :

INPUT														Over Temp. Shutdown /Recover	EFF. (typ.)	MODEL NO.	
Nominal (Range)	UVLO On/Off	Power (Watt)	Voltage (V)				Current (A)			Ripple & Noise		OVP (V)	Short Circuit Protection				
			#	Set Point	Min.*	Max.*	#	Min.	Max.	Peak-Peak	R.M.S.						
12 (10 - 20)	9.7/9.5	50W	+5V	+V1	+5.00	+4.90	+5.10	+I1	+1.0	+6.0	75mV	15mV	5.9	Hiccup Mode Indefinite	+105°C/ +95°C	84%	MH50D1205+12
			+12V	+V2	+12.00	+11.60	+12.30	+I2	+0.05	+1.0	100mV	25mV				86%	MH50D1205+15
			+5V	+V1	+5.00	+4.90	+5.10	+I1	+1.0	+6.0	75mV	15mV	5.9			84%	MH75D1205+12
		+15V	+V2	+15.00	+14.70	+15.50	+I2	+0.05	+1.0	120mV	30mV		86%			MH75D1205+15	
		+5V	+V1	+5.00V	+4.90V	+5.10V	+I1	+1.0	+8.0	75mV	15mV	5.9	84%			MH50D2405+12	
		+12V	+V2	+12.0V	+11.60	+12.30	+I2	+0.01	+2.0	100mV	25mV		88%			MH50D2405+15	
24 (18 - 36)	17/16	50W	+5V	+V1	+5.00	+4.90	+5.10	+I1	+1.0	+6.0	75mV	15mV	5.9	Hiccup Mode Indefinite	+105°C/ +95°C	86%	MH50D2405+12
			+12V	+V2	+12.0	+11.60	+12.30	+I2	+0.01	+1.0	100mV	25mV				88%	MH50D2405+15
			+5V	+V1	+5.00	+4.90	+5.10	+I1	+1.0	+5.0	75mV	15mV	5.9			86%	MH75D2405+12
		+15V	+V2	+15.0	+14.5	+15.5	+I2	+0.01	+1.0	120mV	30mV		88%			MH75D2405+15	
		+5V	+V1	+5.00V	+4.90V	+5.10V	+I1	+1.0	+6.0	75mV	15mV	5.9	86%			MH50D4805+12	
		+12V	+V2	+12.0V	+11.60	+12.30	+I2	+0.01	+1.0	100mV	25mV		88%			MH50D4805+15	
48 (36 - 75)	34/33	50W	+5V	+V1	+5.00	+4.90	+5.10	+I1	+1.0	+6.0	75mV	15mV	5.9	Hiccup Mode Indefinite	+105°C/ +95°C	86%	MH50D4805+12
			+12V	+V2	+12.0	+11.60	+12.30	+I2	+0.01	+1.0	100mV	25mV				88%	MH50D4805+15
			+5V	+V1	+5.00	+4.90	+5.10	+I1	+1.0	+5.0	75mV	15mV	5.9			86%	MH75D4805+12
		+15V	+V2	+15.0	+14.5	+15.5	+I2	+0.01	+1.0	120mV	30mV		88%			MH75D4805+15	
		+5V	+V1	+5.00V	+4.90V	+5.10V	+I1	+1.0	+6.0	75mV	15mV	5.9	84%			MH50D24W05+12	
		+12V	+V2	+12.0	+11.60	+12.30	+I2	+0.01	+1.0	100mV	25mV		86%			MH50D24W05+15	
24W (10 - 30)	9.7/9.5	50W	+5V	+V1	+5.00	+4.90	+5.10	+I1	+1.0	+6.0	75mV	15mV	5.9	Hiccup Mode Indefinite	+105°C/ +95°C	84%	MH50D24W05+12
			+12V	+V2	+12.0	+11.60	+12.30	+I2	+0.01	+1.0	100mV	25mV				86%	MH50D24W05+15
			+5V	+V1	+5.00V	+4.90V	+5.10V	+I1	+1.0	+6.0	75mV	15mV	5.9			84%	MH75D24W05+12
		+15V	+V2	+15.0V	+14.5V	+15.5V	+I2	+0.01	+1.0	120mV	30mV		86%			MH75D24W05+15	
		+5V	+V1	+5.00V	+4.90V	+5.10V	+I1	+1.0	+5.0	75mV	15mV	5.9	86%			MH50D48W05+12	
		+12V	+V2	+12.0V	+11.60	+12.30	+I2	+0.01	+1.0	100mV	25mV		88%			MH50D48W05+12	
48W (18 - 36)	17/16	50W	+5V	+V1	+5.00	+4.90	+5.10	+I1	+1.0	+6.0	75mV	15mV	5.9	Hiccup Mode Indefinite	+105°C/ +95°C	86%	MH50D48W05+12
			+12V	+V2	+12.0	+11.60	+12.30	+I2	+0.01	+1.0	100mV	25mV				88%	MH50D48W05+12
			+5V	+V1	+5.00	+4.90	+5.10	+I1	+1.0	+5.0	75mV	15mV	5.9			86%	MH75D48W05+12
		+15V	+V2	+15.0	+14.5	+15.5	+I2	+0.01	+1.0	120mV	30mV		88%			MH75D48W05+12	
		+5V	+V1	+5.00V	+4.90V	+5.10V	+I1	+1.0	+6.0	75mV	15mV	5.9	86%			MH50D24W05+12	
		+12V	+V2	+12.0V	+11.60	+12.30	+I2	+0.01	+1.0	100mV	25mV		86%			MH50D24W05+15	

* Combined Line & Load (Low Line to High Line, Min. Load to Full Load)

Product Numbering System & Selection Guide

Series No.	Output Power	No Output	Input Voltage	V1 Output	V2/V3 Output	Options
MH	50 : 50W 75 : 75W	D : Dual	12 : 10-20V 24 : 18-36V 48 : 36-75V	05 : 5.0V	+12 : +12V +15 : +15V	C : -55°C Operation MC : Metal Case TS : Terminal Strip
			24W : 10-36V 48W : 20-75V			

BLOCK DIAGRAM

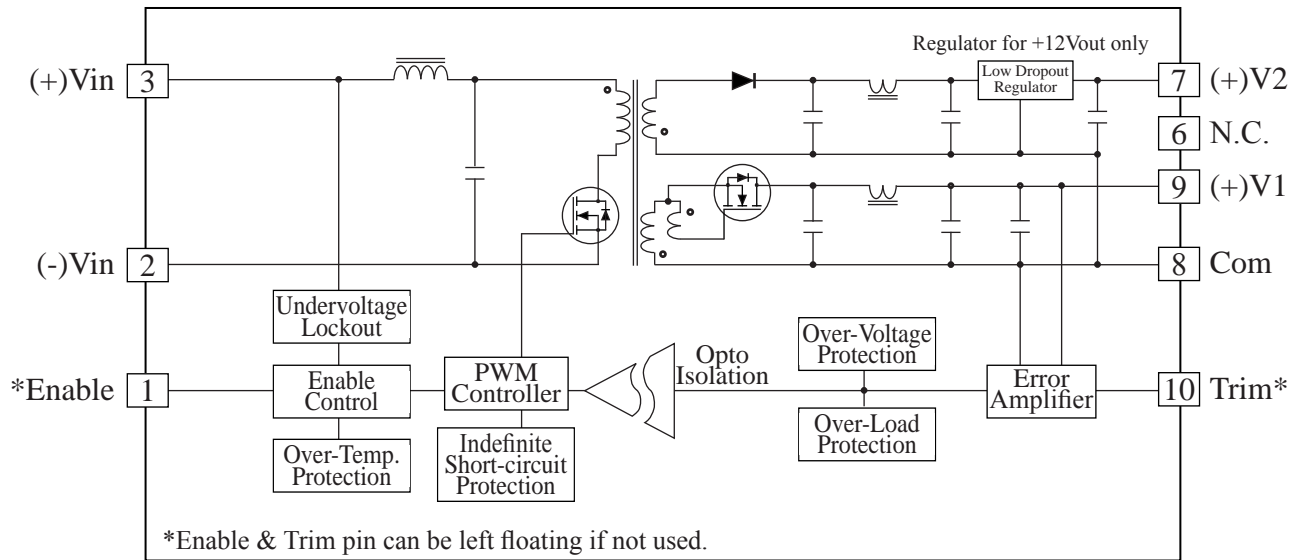

Open Frame (Standard)

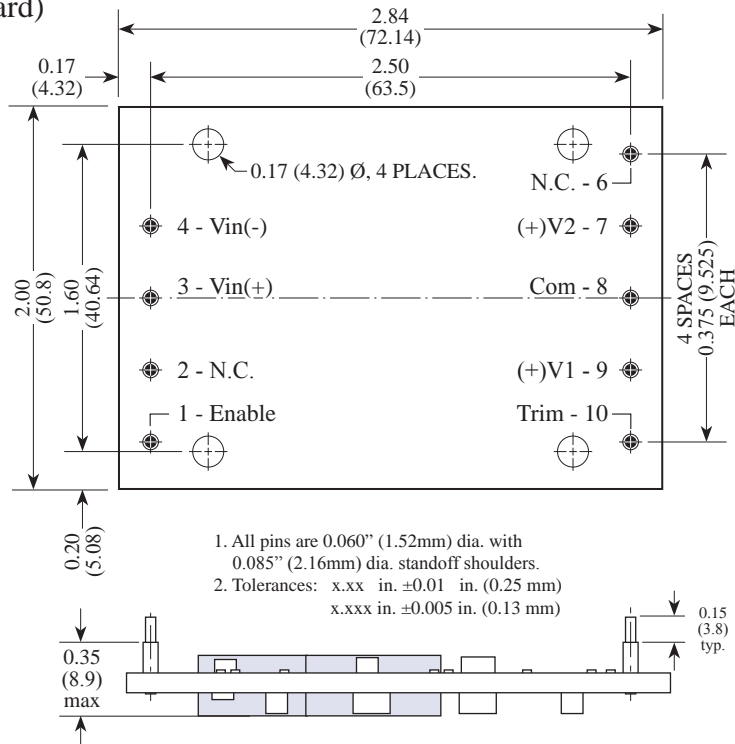

Encapsulated (Optional, MC Suffix)

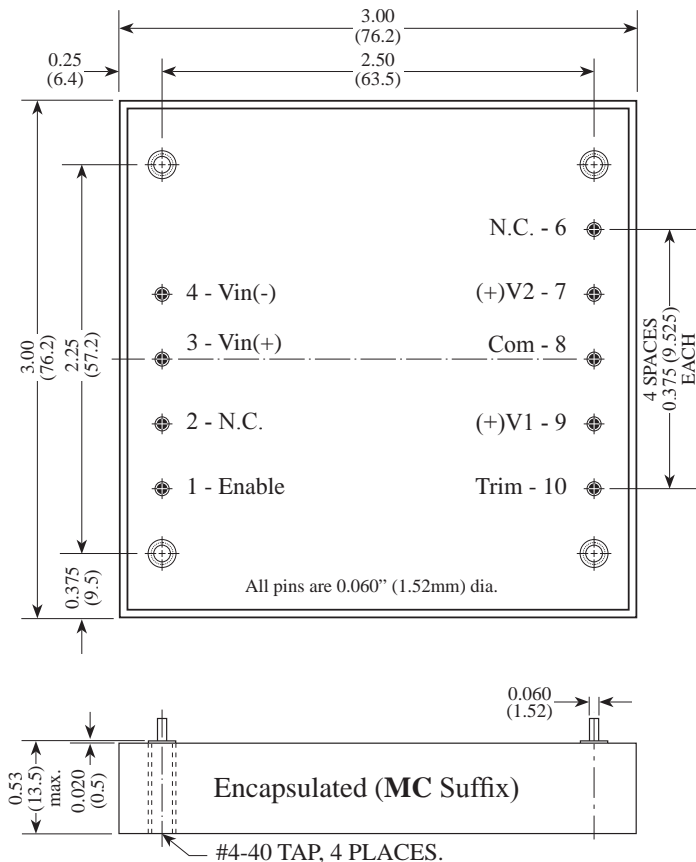

Chassis Mount (Optional, TS Suffix)

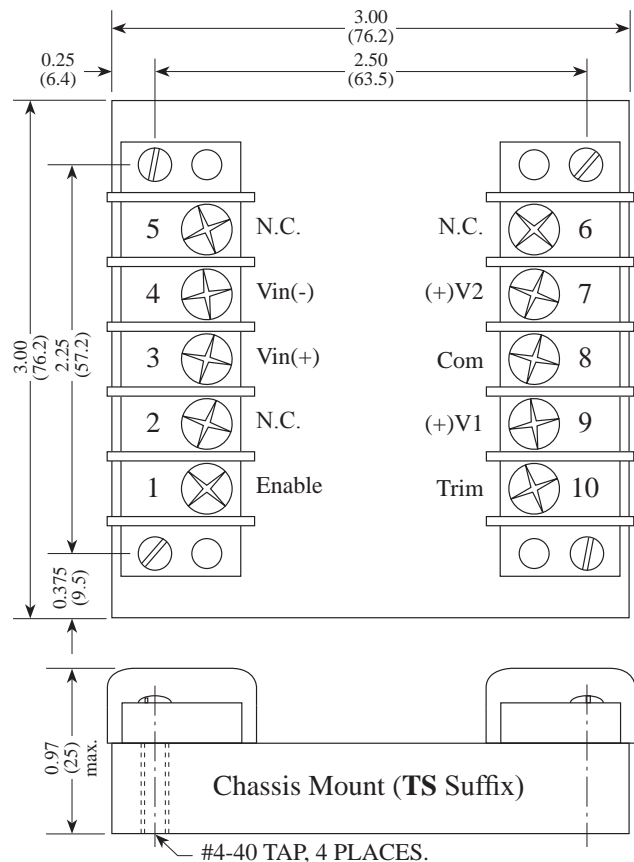

NOTE :

INPUT			OUTPUT											Over Temp. Shutdown /Recover	EFF. (typ.)	MODEL NO.	
Nominal (Range)	UVLO On/Off	Power (Watt)	Voltage (V)				Current (A)			Ripple & Noise		OVP (V)	Short Circuit Protection				
			#	Set Point	Min.*	Max.*	#	Min.	Max.	Peak-Peak	R.M.S.						
12 (10 - 20)	9.7/9.5	50W	+5V ±12V	+V1	+5.00	+4.90	+5.10	+11	+1.0	+6.0	75mV	15mV	5.9	Hiccup Mode Indefinite	+105°C/ +95°C	84%	MH50T1205-12
				+V2	+12.00	+11.70	+12.20	+12	+0.05	+1.0	100mV	25mV					
				-V3	-12.00	-11.70	-12.20	+13	-0.05	-1.0	100mV	25mV					
			+5V ±15V	+V1	+5.00	+4.90	+5.10	+11	+1.0	+6.0	75mV	15mV	5.9			86%	MH50T1205-15
				+V2	+15.00	+14.50	+15.50	+12	+0.05	+1.0	120mV	30mV					
				-V3	-15.00	-14.50	-15.50	+13	-0.05	-1.0	120mV	30mV					
		75W	+5V ±12V	+V1	+5.00V	+4.90V	+5.10V	+11	+1.0	+8.0	75mV	15mV	5.9			84%	MH75T1205-12
				+V2	+12.0V	+11.70	+12.20	+12	+0.01	+2.0	100mV	25mV					
				-V3	-12.0V	-11.70	-12.20	+13	-0.01	-2.0	100mV	25mV					
			+5V ±15V	+V1	+5.00V	+4.90V	+5.10V	+11	+1.0	+5.0	75mV	15mV	5.9			86%	MH75T1205-15
				+V2	+15.0V	+14.5V	+15.5V	+12	+0.05	+2.5	120mV	30mV					
				-V3	-15.0V	-14.5V	-15.5V	+13	-0.05	-2.5	120mV	30mV					
24 (18 - 36)	17/16	50W	+5V ±12V	+V1	+5.00	+4.90	+5.10	+11	+1.0	+6.0	75mV	15mV	5.9	86%	MH50T2405-12		
				+V2	+12.0	+11.70	+12.20	+12	+0.01	+1.0	100mV	25mV					
				-V3	-12.0	-11.70	-12.20	+13	-0.01	-1.0	100mV	25mV					
			+5V ±15V	+V1	+5.00	+4.90	+5.10	+11	+1.0	+5.0	75mV	15mV	5.9	88%	MH50T2405-15		
				+V2	+15.0	+14.5	+15.5	+12	+0.01	+1.0	120mV	30mV					
				-V3	-15.0	-14.5	-15.5	+13	-0.01	-1.0	120mV	30mV					
		75W	+5V ±12V	+V1	+5.00V	+4.90V	+5.10V	+11	+1.0	+6.0	75mV	15mV	5.9	86%	MH75T2405-12		
				+V2	+12.0V	+11.70	+12.20	+12	+0.01	+1.0	100mV	25mV					
				-V3	-12.0V	-11.70	-12.20	+13	-0.01	-1.0	100mV	25mV					
			+5V ±15V	+V1	+5.00V	+4.90V	+5.10V	+11	+1.0	+5.0	75mV	15mV	5.9	88%	MH75T2405-15		
				+V2	+15.0V	+14.5V	+15.5V	+12	+0.01	+1.0	120mV	30mV					
				-V3	-15.0V	-14.5V	-15.5V	+13	-0.01	-1.0	120mV	30mV					
48 (36 - 75)	34/33	50W	+5V ±12V	+V1	+5.00	+4.90	+5.10	+11	+1.0	+6.0	75mV	15mV	5.9	86%	MH50T4805-12		
				+V2	+12.0	+11.70	+12.20	+12	+0.01	+1.0	100mV	25mV					
				-V3	-12.0	-11.70	-12.20	+13	-0.01	-1.0	100mV	25mV					
			+5V ±15V	+V1	+5.00	+4.90	+5.10	+11	+1.0	+5.0	75mV	15mV	5.9	88%	MH50T4805-15		
				+V2	+15.0	+14.5	+15.5	+12	+0.01	+1.0	120mV	30mV					
				-V3	-15.0	-14.5	-15.5	+13	-0.01	-1.0	120mV	30mV					
		75W	+5V ±12V	+V1	+5.00V	+4.90V	+5.10V	+11	+1.0	+6.0	75mV	15mV	5.9	86%	MH75T4805-12		
				+V2	+12.0V	+11.70	+12.20	+12	+0.01	+1.0	100mV	25mV					
				-V3	-12.0V	-11.70	-12.20	+13	-0.01	-1.0	100mV	25mV					
			+5V ±15V	+V1	+5.00V	+4.90V	+5.10V	+11	+1.0	+5.0	75mV	15mV	5.9	88%	MH75T4805-15		
				+V2	+15.0V	+14.5V	+15.5V	+12	+0.01	+1.0	120mV	30mV					
				-V3	-15.0V	-14.5V	-15.5V	+13	-0.01	-1.0	120mV	30mV					
24W (10 - 30)	9.7/9.5	50W	+5V ±12V	+V1	+5.00	+4.90	+5.10	+11	+1.0	+6.0	75mV	15mV	5.9	84%	MH50T24W05-12		
				+V2	+12.0	+11.70	+12.20	+12	+0.01	+1.0	100mV	25mV					
				-V3	-12.0	-11.70	-12.20	+13	-0.01	-1.0	100mV	25mV					
			+5V ±15V	+V1	+5.00	+4.90	+5.10	+11	+1.0	+5.0	75mV	15mV	5.9	88%	MH50T24W05-15		
				+V2	+15.0	+14.5	+15.5	+12	+0.01	+1.0	120mV	30mV					
				-V3	-15.0	-14.5	-15.5	+13	-0.01	-1.0	120mV	30mV					
		75W	+5V ±12V	+V1	+5.00V	+11.70	+12.20	+11	+1.0	+6.0	75mV	15mV	5.9	84%	MH75T24W05-12		
				+V2	+12.0V	-11.70	-12.20	+12	+0.01	+1.0	100mV	25mV					
				-V3	-12.0V	-11.5V	-12.5V	+13	-0.01	-1.0	100mV	25mV					
			+5V ±15V	+V1	+5.00V	+4.90V	+5.10V	+11	+1.0	+5.0	75mV	15mV	5.9	88%	MH75T24W05-15		
				+V2	+15.0V	+14.5V	+15.5V	+12	+0.01	+1.0	120mV	30mV					
				-V3	-15.0V	-14.5V	-15.5V	+13	-0.01	-1.0	120mV	30mV					
48W (18 - 36)	17/16	50W	+5V ±12V	+V1	+5.00	+4.90	+5.10	+11	+1.0	+6.0	75mV	15mV	5.9	86%	MH50T48W05-12		
				+V2	+12.0	+11.70	+12.20	+12	+0.01	+1.0	100mV	25mV					
				-V3	-12.0	-11.70	-12.20	+13	-0.01	-1.0	100mV	25mV					
			+5V ±15V	+V1	+5.00	+4.90	+5.10	+11	+1.0	+5.0	75mV	15mV	5.9	88%	MH50T48W05-12		
				+V2	+15.0	+14.5	+15.5	+12	+0.01	+1.0	120mV	30mV					
				-V3	-15.0	-14.5	-15.5	+13	-0.01	-1.0	120mV	30mV					
		75W	+5V ±12V	+V1	+5.00V	+4.90V	+5.10V	+11	+1.0	+6.0	75mV	15mV	5.9	86%	MH75T48W05-12		
				+V2	+12.0V	+11.70	+12.20	+12	+0.01	+1.0	100mV	25mV					
				-V3	-12.0V	-11.70	-12.20	+13	-0.01	-1.0	100mV	25mV					
			+5V ±15V	+V1	+5.00V	+4.90V	+5.10V	+11	+1.0	+5.0	75mV	15mV	5.9	88%	MH75T48W05-12		
				+V2	+15.0V	+14.5V	+15.5V	+12	+0.01	+1.0	120mV	30mV					
				-V3	-15.0V	-14.5V	-15.5V	+13	-0.01	-1.0	120mV	30mV					

* Combined Line & Load (Low Line to High Line, Min. Load to Full Load)

BLOCK DIAGRAM

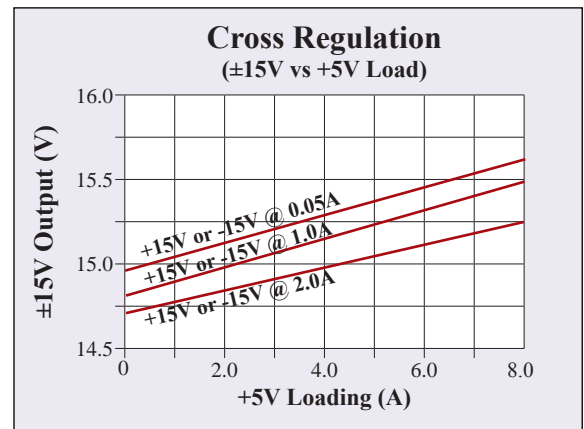
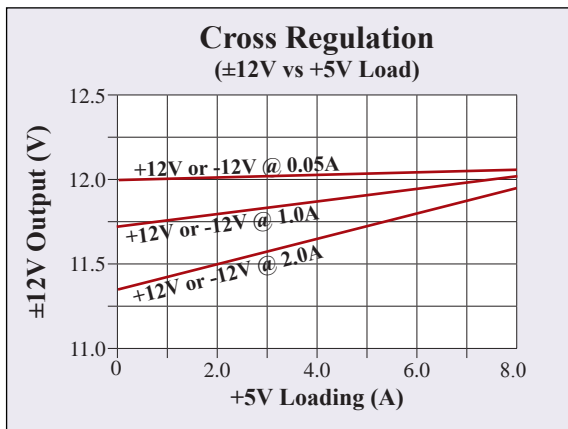
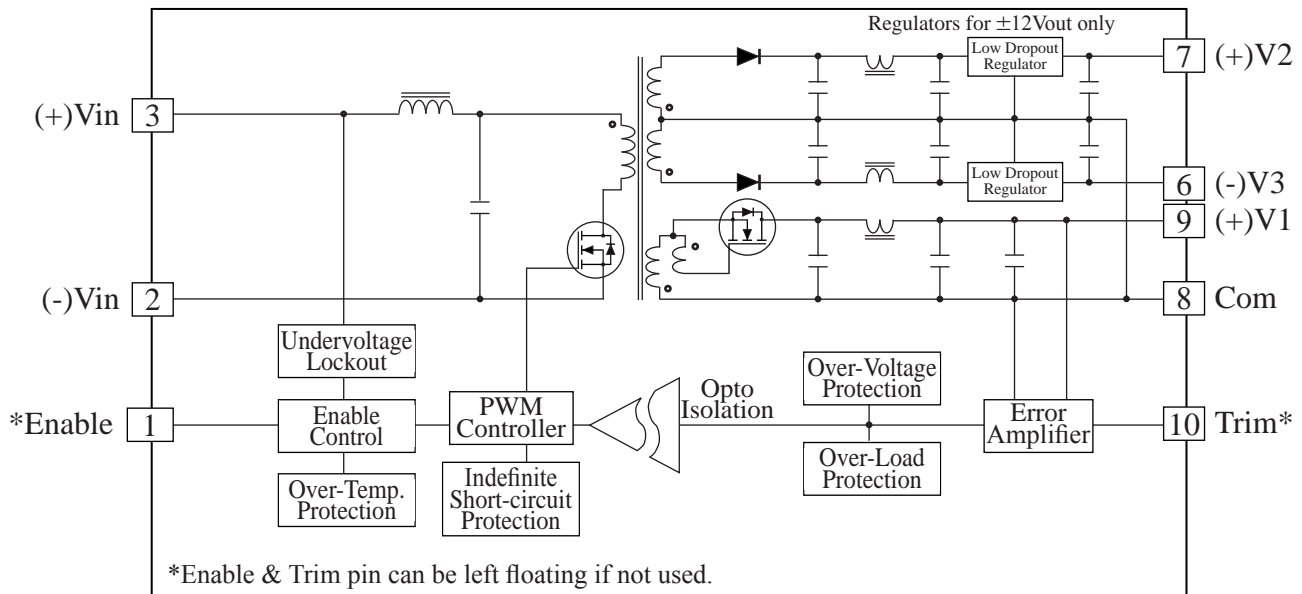

Product Numbering System & Selection Guide

Series No.	Output Power	No Output	Input Voltage	V1 Output	V2/V3 Output	Options
MH	50 : 50W 75 : 75W	T : Triple	12 : 10-20V 24 : 18-36V 48 : 36-75V 24W : 10-36V 48W : 20-75V	05 : 5.0V	-12 : ±12V -15 : ±15V	C : -55°C Operation MC : Metal Case TS : Terminal Strip

Open Frame (Standard)

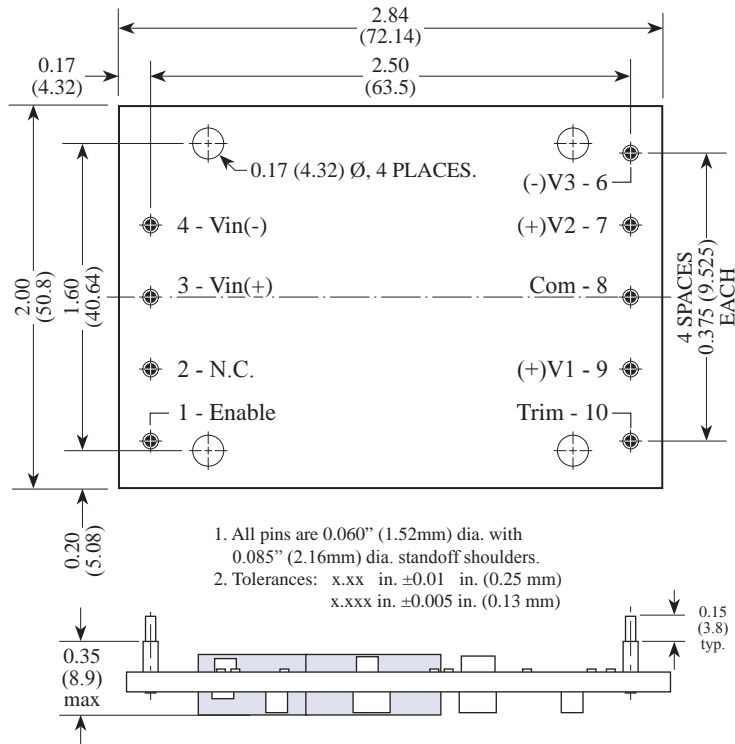

Metal Case (Optional, MC Suffix)

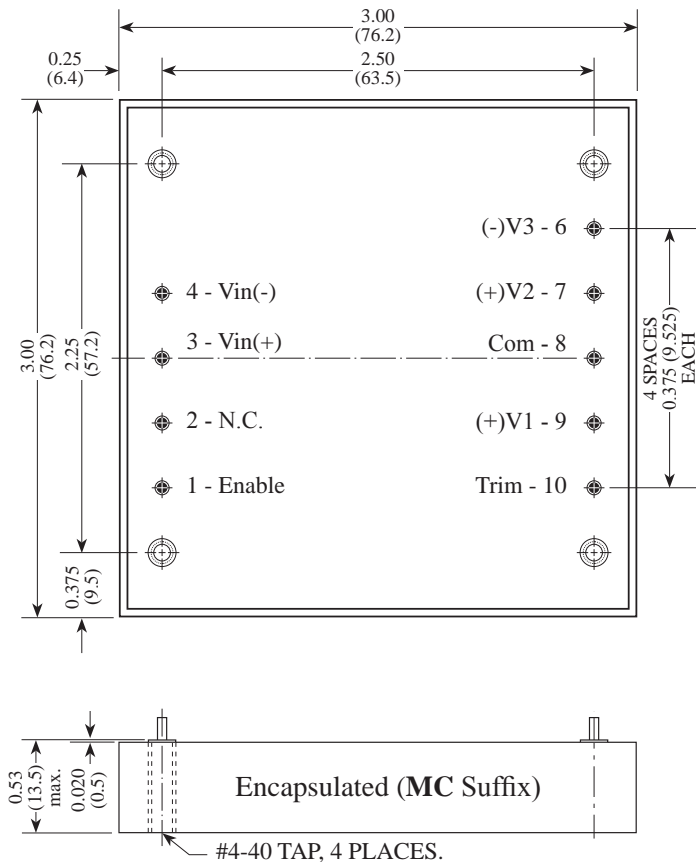

Chassis Mount (Optional, TS Suffix)

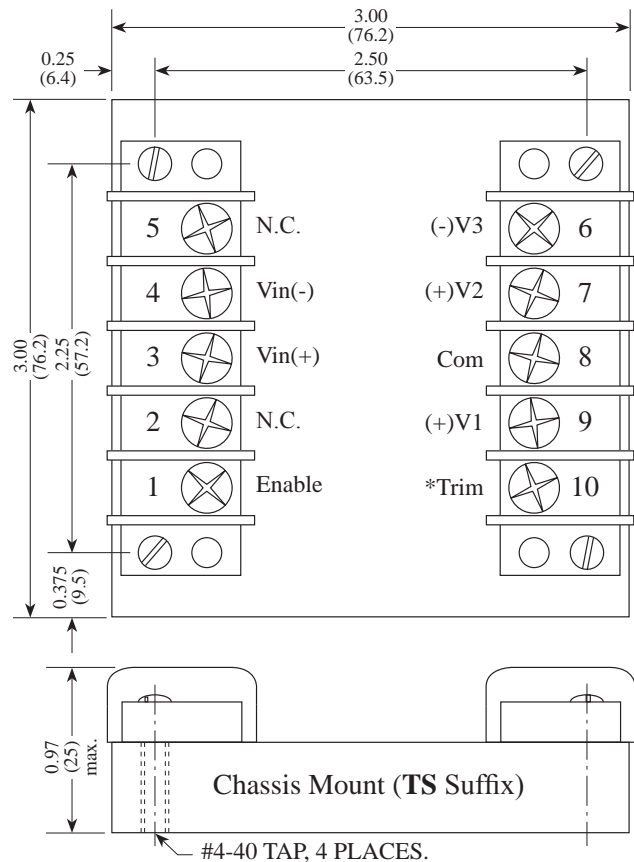

Efficiency Curve

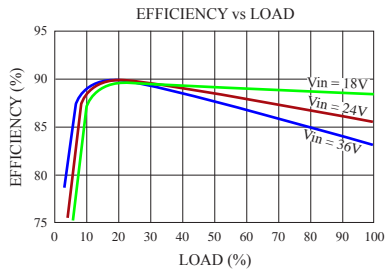

MH75T2405-12

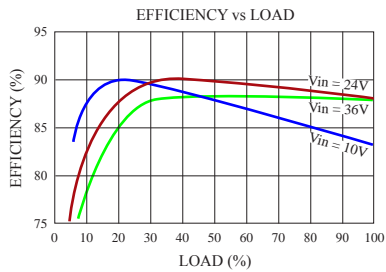

MH75T24W05-12

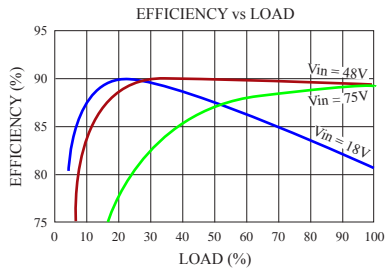

MH75T48W05-12

Transient Response

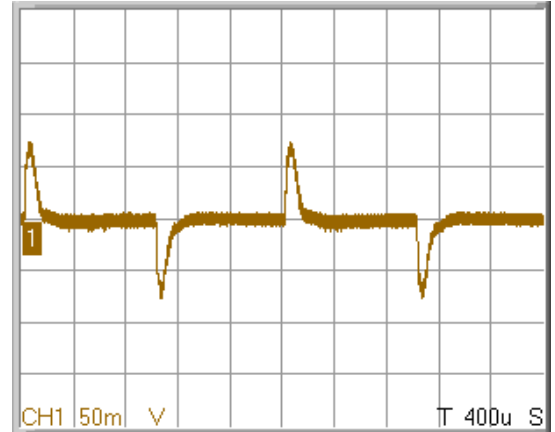

+5V

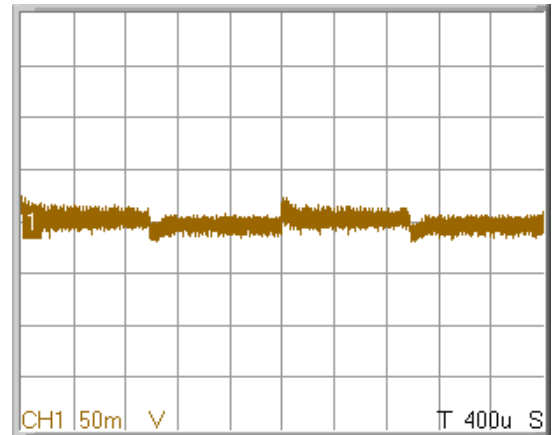

+12V

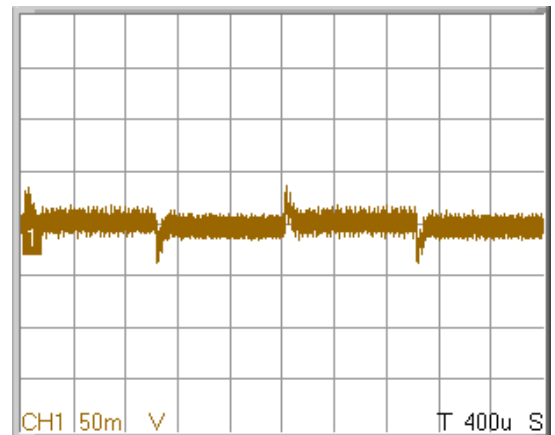

-12V