

Input Ranges :

240-420 VDC

Output Voltage:

Single Output

3.3V - 48V

Dual Output

+3.3V/+2.5V,

+3.3V/+1.8V,

+5.0V/+3.3V

+5.0V/+2.5V

+5.0V/+1.8V

Triple Output

+3.3V/+2.5V/+13V,

+3.3V/+1.8V/+13V,

+5.0V/+3.3V/+15V

+5.0V/+2.5V/+15V,

+5.0V/+1.8V/+15V

Output Power:

130 to 225 W

FEATURES

General:

- Small Footprint : 2.84" x 2.84"
- High Output Power : to 225 watts
- Current Sharing
- Synchronization : Input & Output
- Wide Input Range : 240-420Vdc
- Encapsulated with Metal Case
- Integral PCB Transformer
- High Conversion Efficiency to 91%
- Line & Load Regulation to $\pm 0.5\%$
- Fixed Operating Frequency

Protection:

- Output Over-Voltage Protection
- Output Over-Load Protection
- Hiccup Mode Short Circuit protection
- Over-Temperature Protection
- Input Under-Voltage Lock-Out

Control:

- Enable (On/Off) Control
- Output Voltage Trim

Isolation:

- Isolation Voltage > 1500V



MK series is a family of high power density, high efficiency, and high reliability DC-DC Converters. It provides up to 50W output in a 2.84" x 2.84" footprint. The wide input range of 240 to 390 vdc is ideal for unregulated input applications. Integral PCB transformer / inductor is used for all models in this series. This new design technique has greatly improved the magnetic coupling, reduced switching spike and provided performance consistency. It also streamlines the production process by completely eliminating the hand-wind magnetic assembly process from production lines.

MK series provides the most extensive protection to safeguard both the power converter and the load. It includes output over-voltage protection, over-current protection, hiccup mode indefinite short circuit protection and under-voltage lockout. Over-current inception point is set at about 115% of rated load. Hiccup mode cycles for 28mSec periods with 3mSec on and 25mSec off. Over-temperature shutdown, activated at +105°C of board temperature, will recover when the temperature falls below +95°C.

MK series features low output noise, very tight line and load regulation, and high efficiency. No external capacitor requirement for normal operation.

TABLE OF CONTENTS :

General Specifications	2
Single Output	4
Dual Output	10
Triple Output.....	12

1. Absolute Maximum Ratings

Stresses in excess of the absolute maximum ratings can cause performance degradation, adversely effect longterm reliability, and cause permanent damage to the device.

Parameter	Conditions / Description	Min	Max	Units
Input Voltage				
Continuous		-0.3	420	Vdc
Transient		-0.3	430	Vdc
Operating Temperature	All models, base plate temperature	-40	+105	°C
Storage Temperature	Ambient	-55	+125	°C
Isolation Voltage	Input to Output		+2000	Vdc

2. Input Specifications

Parameter	Conditions / Description	Min	Nom	Max	Units
Input Voltage					
Voltage Range (Continuous)		240	300	420	Vdc
Under-Voltage Lockout (UVLO)					
Turn-On Threshold (Ramping Up)			235		Vdc
Turn-Off Threshold (Ramping Down)			230		Vdc

3. Enable (On-Off Control)

Parameter	Conditions / Description	Min	Nom	Max	Units
Enable Pin					
Open Circuit Voltage			10		Vdc
Source Current	Enable pin is connected to -Vin			1	mA
Positive Logic	Standard				
On-Control	(or Floating Enable Pin)	2.5		10	Vdc
Off-Control		-0.5		1.8	Vdc

4. Sync-In

Parameter	Conditions / Description	Min	Nom	Max	Units
Clock Amplitude			4.0	6.0	Vdc
Clock Pulse Width		0.5		1	µSec.
Capture Frequency Range		270		340	KHz

5. I-Share

Parameter	Conditions / Description	Min	Nom	Max	Units
Forced Current Share Accuracy	% of Output Rated Current		10		%A

6. Output Specifications

Parameter	Conditions / Description	Min	Nom	Max	Units
Voltage Accuracy	Please see table				%
Output Current	Please see table				Adc
Output Trim				±10	%Vout
Over Voltage Protection			15		%Vdc
Line Regulation				0.1	%Vout
Load Regulation				0.2	%Vout
Transient Respoonse	50% ± 25% step load change		400		µSec.
Ripple & Noise	Please see table				mVp-p
Switching Frequency			300		KHz

7. Sync-Out

Parameter	Conditions / Description	Min	Nom	Max	Units
Interface	Open Collector				
Voltage				20	Vdc
Current				10	mA

MK Series, 150W

8. Power Good Signal

Parameter	Conditions / Description	Min	Nom	Max	Units
Power Good Sense Level	% of Rated Output Voltage	90		115	%Vdc
Power Good			5.0		Vdc
Output Source Current				5.0	mA

8. FET Drive

Parameter	Conditions / Description	Min	Nom	Max	Units
Drive Voltage	Voltage above (+)Vout		7.5		Vdc
Output Source Current				5.0	mA

10. Output Trim

Parameter	Conditions / Description	Min	Nom	Max	Units
Negative Trim	Standard				
Trim Up	Trim Pin to (-)Sense			10	%Vdc
Trim Down	Trim Pin to (+)sense	5			%Vdc
Positive Trim	Not Available				

11. Environmental and Mechanical Specifications

Parameter	Conditions / Description	Min	Nom	Max	Units
Operating Temperature					
Standard		-25		+105	°C
Extended		-55		+105	°C
Storage Temperature		-55		+125	°C
Temperature Coefficient				±0.02	%/°C
Shock	Halfsine wave, 3 axes	50			g
Sinusoidal Vibration	GR-63-CORE, Section 5.4.2	1			g
Humidity	Relative Humidity, Non-Condensing			95	%R.H.
Weight			5.8(165)		Oz(g)
MTBF (calculated)	Bellcore TR-NWT-000332 method 1 - parts count	1			MHrs

12. Isolation Specifications

Parameter	Conditions / Description	Min	Nom	Max	Units
Isolation Voltage					
Input to Output		1500			Vdc
I/O to Case		1000			Vdc
Isolation Resistance	Input to Output	10			MΩ
Isolation Capacitance	Input to Output		3		nF

13. Protections

Parameter	Conditions / Description	Min	Nom	Max	Units
Over-Load Protection					
Type	Current-Mode, Pulse by Pulse Current Limit				
Threshold	% Rated Load		120		%
Short-Circuit Protection					
Type	Hiccup Mode, Non-Latching, Auto-Recovery				
Threshold	Short-Circuit Resistance			65	mΩ
Over-Temperature Protection					
Type	Non-Latching, Auto-Recovery				
Threshold	PCB Temperature		115		°C
Hysteresis			15		°C
Over-Voltage Protection					
Type	Auxiliary Feedback Loop Control				
Set-Point				120	%Vout

MK Series, Single Output 130-150W

INPUT		OUTPUT									Over Temp. Shutdown /Recover	EFF. (typ.)	Pin-Out	MODEL NO.	
Nominal (Range)	UVL (On/Off)	Max Power (Watts)	Voltage (V)			Current (A)		Ripple & Noise		OVP					Short Circuit Protection
			Set Point	Min.*	Max.*	Min.	Max.	Peak-Peak	R.M.S.						
300V (240V/ 420V)	235V /230V	130	3.30	3.20	3.40	0	30	75mV	15mV	3.9V	Hiccup Mode Indefinite	+105°C/ +95°C	88%	I	MK100S3H033
		165		3.20	3.40	0	50	75mV	15mV	3.9V			88%	I	MK165S3H033
		150	5.00	4.90	5.10	0	30	75mV	15mV	5.9V			89%	I	MK150S3H05
		200		4.90	5.10	0	40	75mV	15mV	5.9V			89%	I	MK200S3H05
		150	12.00	11.88	12.12	0	12.5	80mV	20mV	15V			91%	II	MK150S3H12
		225		11.88	12.12	0	19.0	80mV	20mV	15V			91%	II	MK225S3H12
		150	15.00	14.85	15.15	1.0	10.0	100mV	20mV	18V			91%	II	MK150S3H15
		225		14.85	15.15	1.5	15.0	100mV	20mV	18V			91%	II	MK225S3H15
		150	24.00	23.76	24.24	0.6	6.25	200mV	25mV	28V			93%	II	MK150S3H24
		225		23.76	24.24	0.9	9.40	200mV	25mV	28V			93%	II	MK225S3H24
		150	28.00	27.70	28.30	0.5	5.40	240mV	30mV	33V			93%	II	MK150S3H28
		225		27.70	28.30	0.8	8.00	240mV	30mV	33V			93%	II	MK225S3H28
		150	48.00	47.50	48.50	0.3	3.20	400mV	40mV	57V			93%	II	MK150S3H48
		225		47.50	48.50	0.4	4.70	400mV	40mV	57V			93%	II	MK225S3H48

*Combined Line & Load Regulation.

Product Numbering System & Selection Guide

Series No.	Output Power	No Output	Input Voltage Range	Output Voltage	Options
MK	100 : 100W 150 : 150W 225 : 225W	S : Single	3H : 240-420V	033 : 3.3V 05 : 5.0V 12 : 12V 15 : 15V 24 : 24V 48 : 48V	C : Extended Temp. MC : Encapsulated S : Sync-Out TS : Chassis Mount

MK Series, Single Output 130-150W

BLOCK DIAGRAM

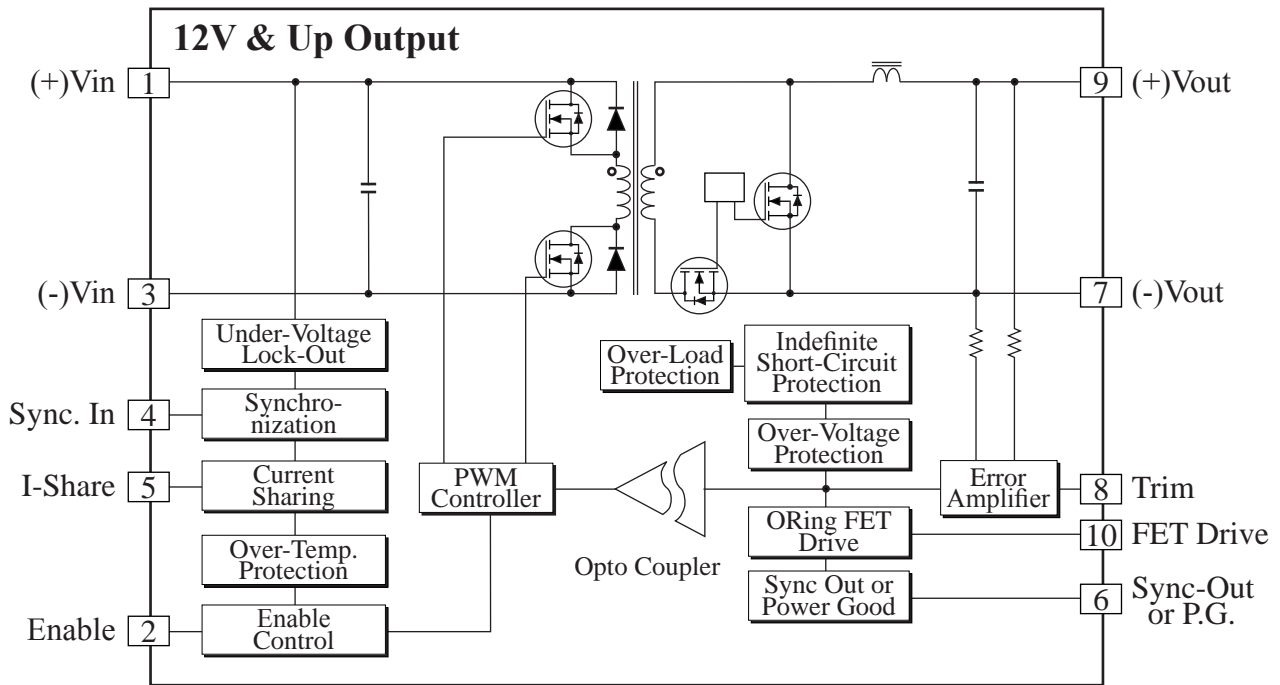
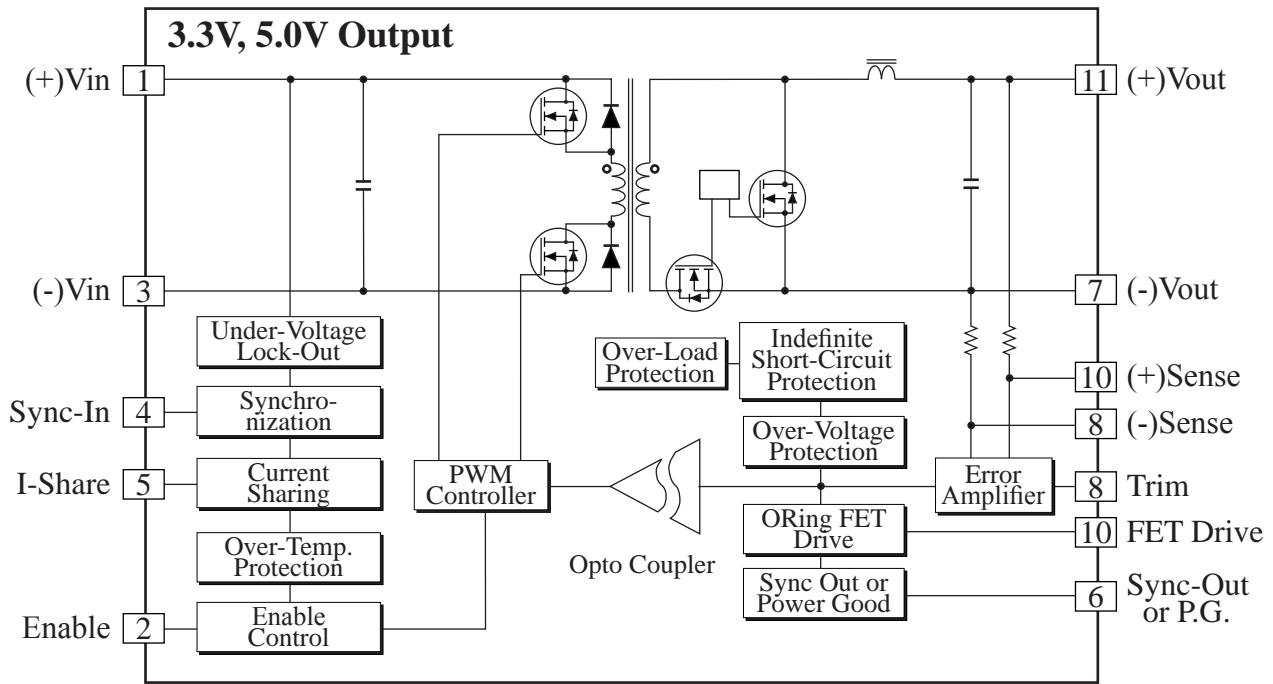

Sync-In :
(270KHz ~ 340KHz)

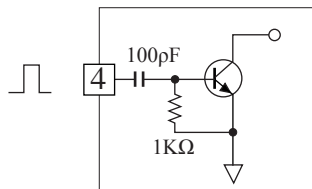

Sync-Out :

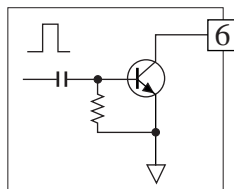

Power Good:

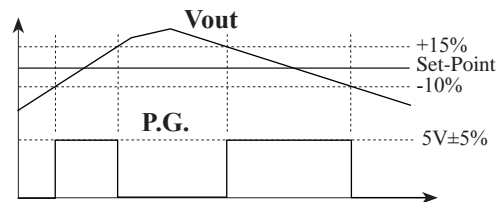

MK Series, Single Output 130-150W

Open Frame (Pin-Out I, 3.3V & 5.0V)

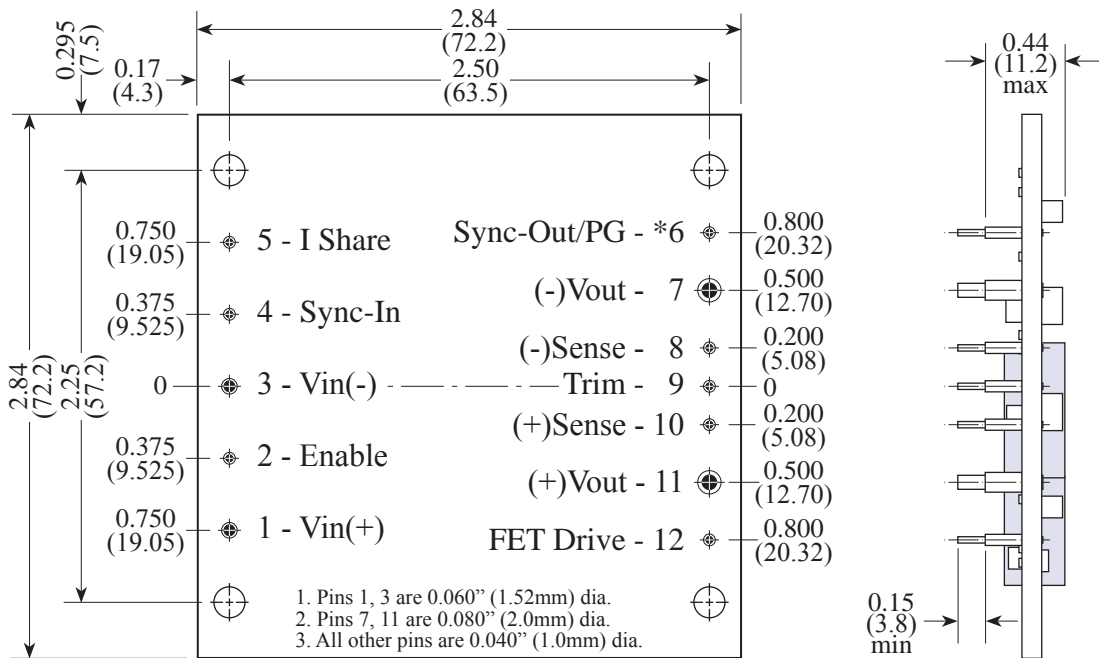

* **PG** (Power Good) - Standard
Sync-Out - Optional (Suffix - S)

Open Frame (Pin-Out II, 12V & Up)

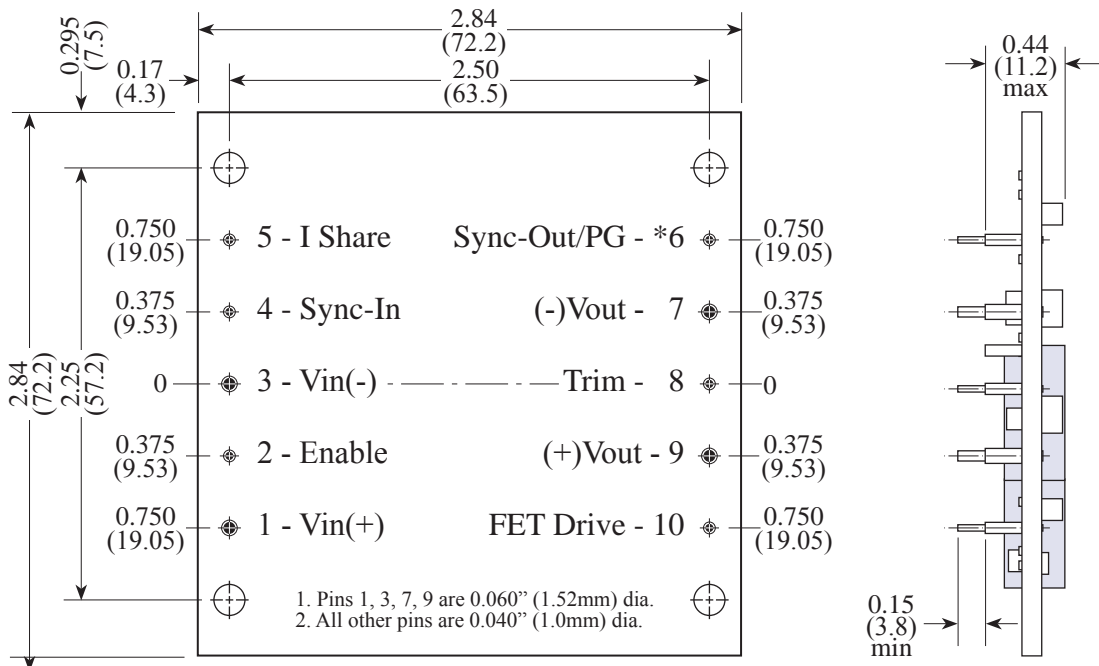

* **PG** (Power Good) - Standard
Sync-Out - Optional (Suffix - S)

MK Series, Single Output 130-150W

Encapsulated (Pin-Out I, 3.3V & 5.0V)

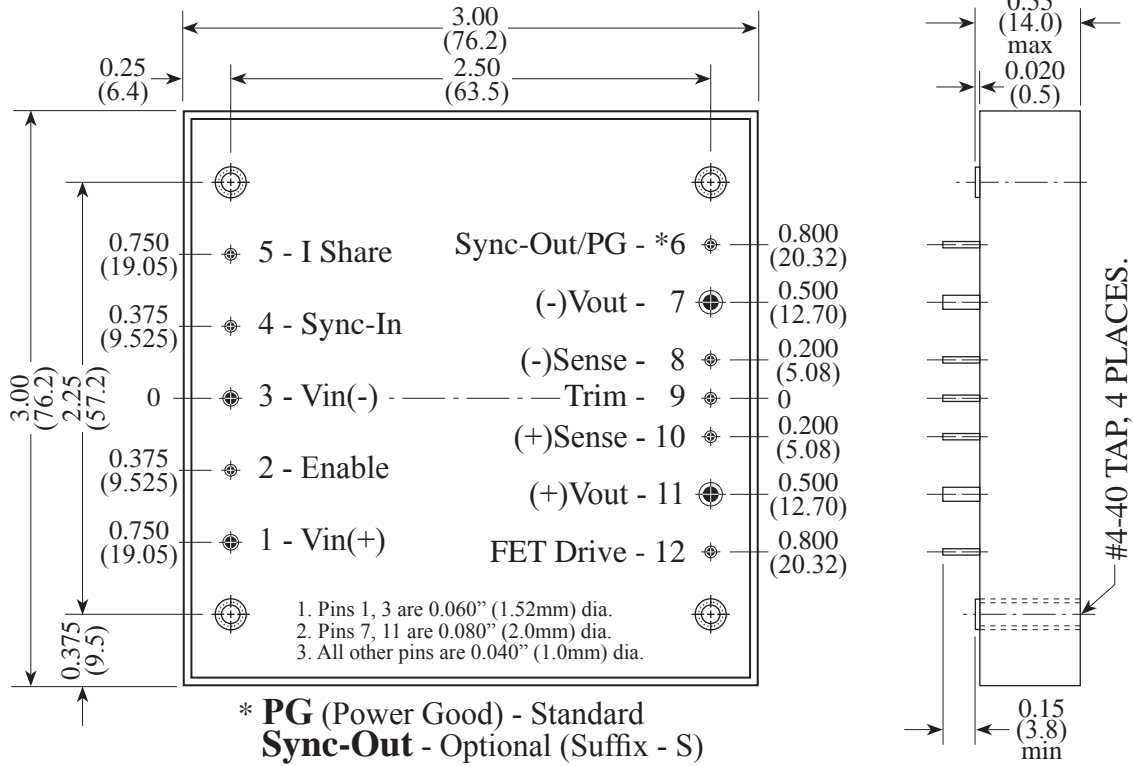

Encapsulated (Pin-Out II, 12V & Up)

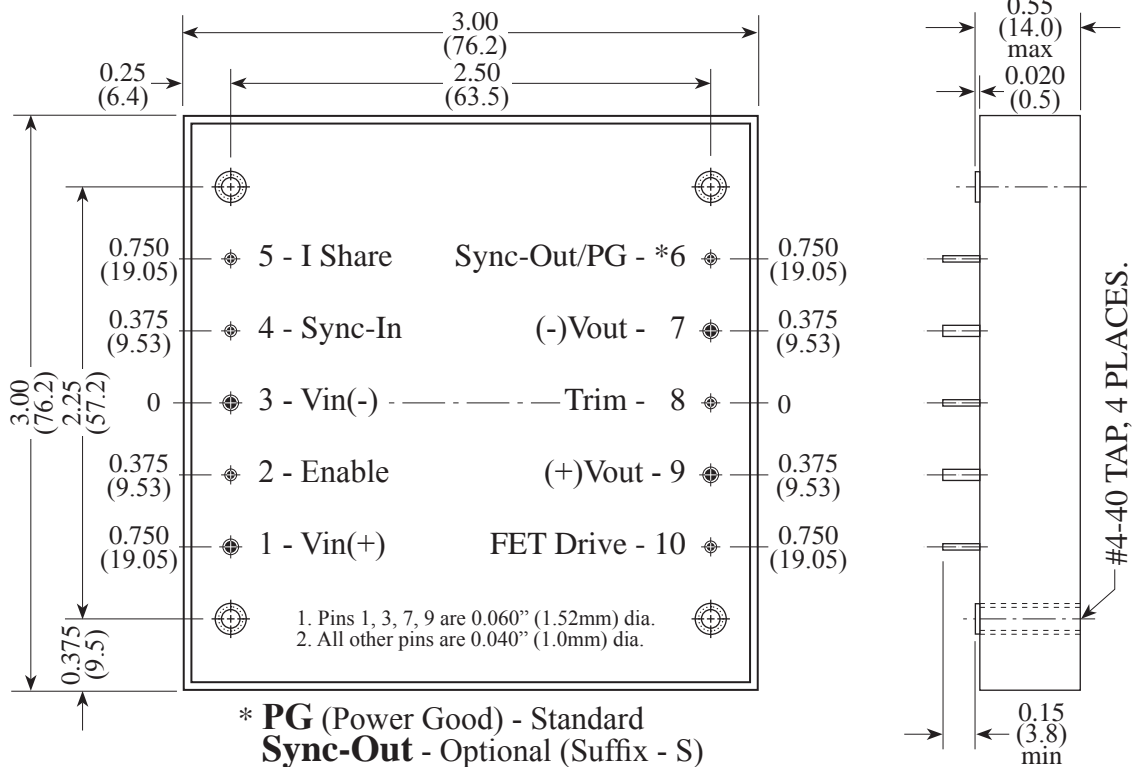

MK Series, Single Output 130-150W

Chassis Mount (Pin-Out II only, 12V & Up)

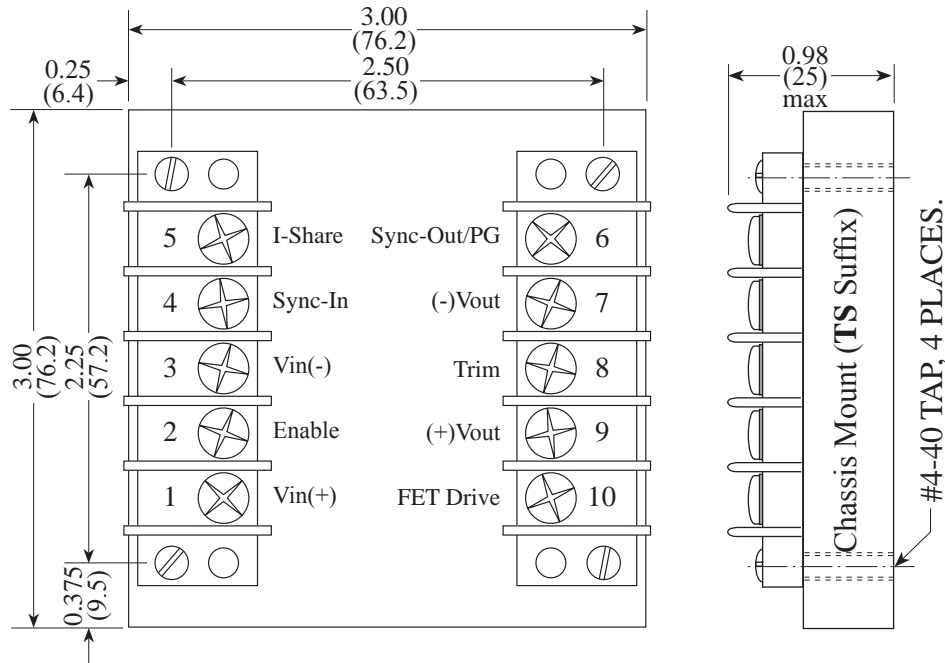

Enable

This pin provides the remote On/Off control function. Two control logics are available: Positive & Negative. Positive logic turns the module ON during a logic high voltage on the enable pin, and OFF during a logic low. Negative logic turns the module OFF during a logic high and ON during a logic low. Positive logic is the standard factory configuration. Negative Enable Logic can be specified with suffix N. The Enable pin can be left floating if not used.

Sync-In

This pin can be connected either to external clock or directly to the Sync-In pin of another MKS, MKD or MKT module. If the Sync-In pin is connected to another module's Sync-In pin, the connection should be as direct as possible, and the Vin(-) pins of the modules must be shorted together. If an external clock signal is applied to the Sync-In pin, the signal must be a 300KHz (± 30 KHz) square wave with a ≥ 4 Vp-p amplitude. The Sync-In pin can be left floating if not used.

I-Share

Two or more modules can be operated in parallel for either redundant operation or additional power requirements. Connect I-Share pin together will force load sharing between the connected modules. To implement forced load sharing, the Sync-In pins of all units must be connected together also. The I-Share pin can be left floating if not used.

Sync-Out

This pin contains a clock signal referenced to the (-)Vout pin. The frequency of this signal will equal either the module's internal clock frequency or the frequency established by an external clock applied to the Sync-In pin. The Sync-Out pin can be left floating if not used.

Sense

Remote sensing allows the converter to sense the output voltage directly at the point of load and thus automatically compensates the load conductor distribution & contact losses. There is one sense lead for each output terminal, designated +Sense and -Sense. These leads carry very low current compared with the load leads. Internally a resistor is connected between sense terminal and power output terminal. If the remote sense is not used, the sense leads need to be shorted to their respective output leads. Care has to be taken when making output connections. If the output terminals should disconnect before the sense lines, the full load current will flow down the sense lines and damage the internal sensing resistors. Be sure to always power down the converter before making any output connections. The maximum compensation voltage for line drop is up to 0.5V

Trim

Output voltage set-point can be increased or decreased by connecting a trimming resistor between trim pin and either the (+)Vout pin or the (-)Vout pin. The trim function is a negative logic. Connecting resistor from trim pin to (-)Vout will trim the voltage up. The trim pin can be left floating if not used.

MK Series, Single Output 130-150W

Parallel Operation

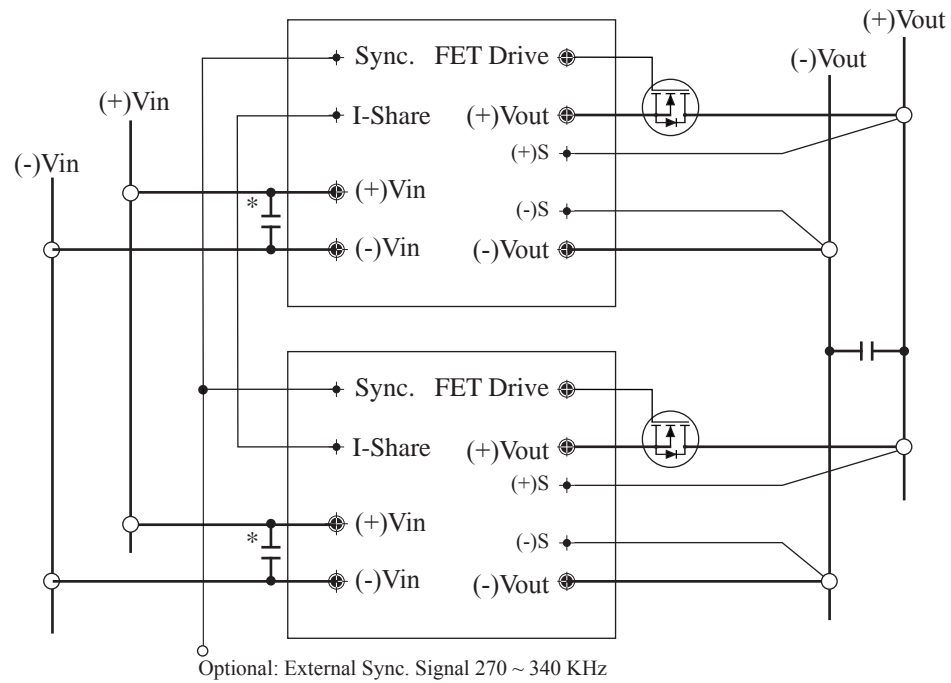

* External input capacitor is required if the power source located more than 3" away.

MK Series, Dual Output 130-150W

INPUT		OUTPUT											Over Temp. Protect	EFF. (typ.)	MODEL NO.	
Nominal (Range)	UVLO On/Off	Power (Watt)	Voltage (V)				Current (A)			Ripple & Noise		Short Circuit Protection				
			#	Set Point	Min.*	Max.*	#	Min.	Max.	Peak-Peak	R.M.S.					
300 (240 - 420)	230V/ 220V	130	+3.3V	+V1	+3.30	+3.20	+3.40	+I1	0	+40.0	75mV	15mV	Hiccup Mode Indefinite	+105°C Recover +95°C	86%	MK150D3H03325
			+2.5V	-V2	+2.50	+2.40	+2.60	+I2	0	+20.0	75mV	15mV				
		130	+3.3V	+V1	+3.30	+3.20	+3.40	+I1	0	+40.0	75mV	15mV			86%	MK150D3H03318
			+1.8V	-V2	+1.80	+1.75	+1.85	+I2	0	+20.0	75mV	15mV				
		150	+5.0V	+V1	+5.00	+4.90	+5.10	+I1	0	+30.0	75mV	15mV			88%	MK150D3H05033
			+3.3V	-V2	+3.30	+3.20	+3.40	+I2	0	+20.0	75mV	15mV				
		150	+5.0V	+V1	+5.00	+4.90	+5.10	+I1	0	+30.0	75mV	15mV			87%	MK150D3H05025
			+2.5V	-V2	+2.50	+2.40	+2.60	+I2	0	+20.0	75mV	15mV				
		150	+5.0V	+V1	+5.00	+4.90	+5.10	+I1	0	+30.0	75mV	15mV			86%	MK150D3H05018
			+1.8V	-V2	+1.80	+1.75	+1.85	+I2	0	+20.0	75mV	15mV				

* Combined Line & Load (Low Line to High Line, Min. Load to Full Load)

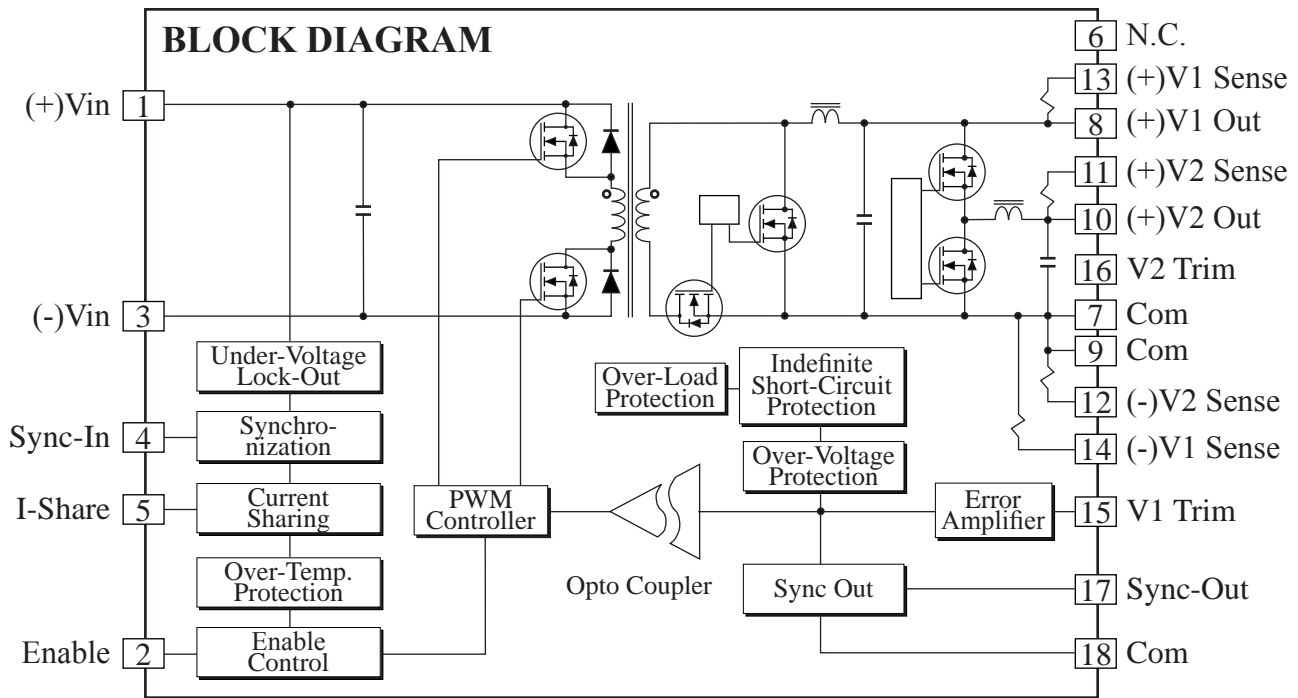

Sync-In :
(270KHz ~ 340KHz)

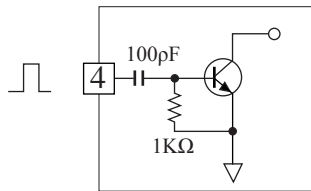

Sync-Out :

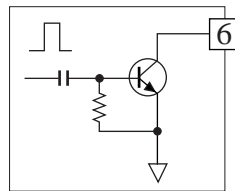

Power Good:

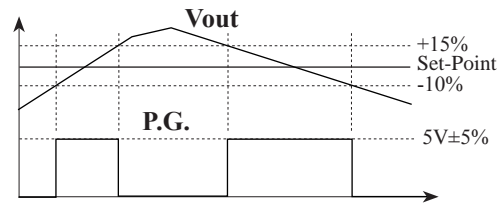

Product Numbering System & Selection Guide

Series No.	Output Power*	No Output	Input Voltage	+V1 Output	+V2 Output	Options
MK	150 : 150W	D : Dual	3H : 240-420V	033 : 3.3V 050 : 5.0V	33 : 3.3V 25 : 2.5V 18 : 1.8V	C : Extended Temp. MC : Encapsulated

MK Series, Dual Output 130-150W

Open Frame (Standard)

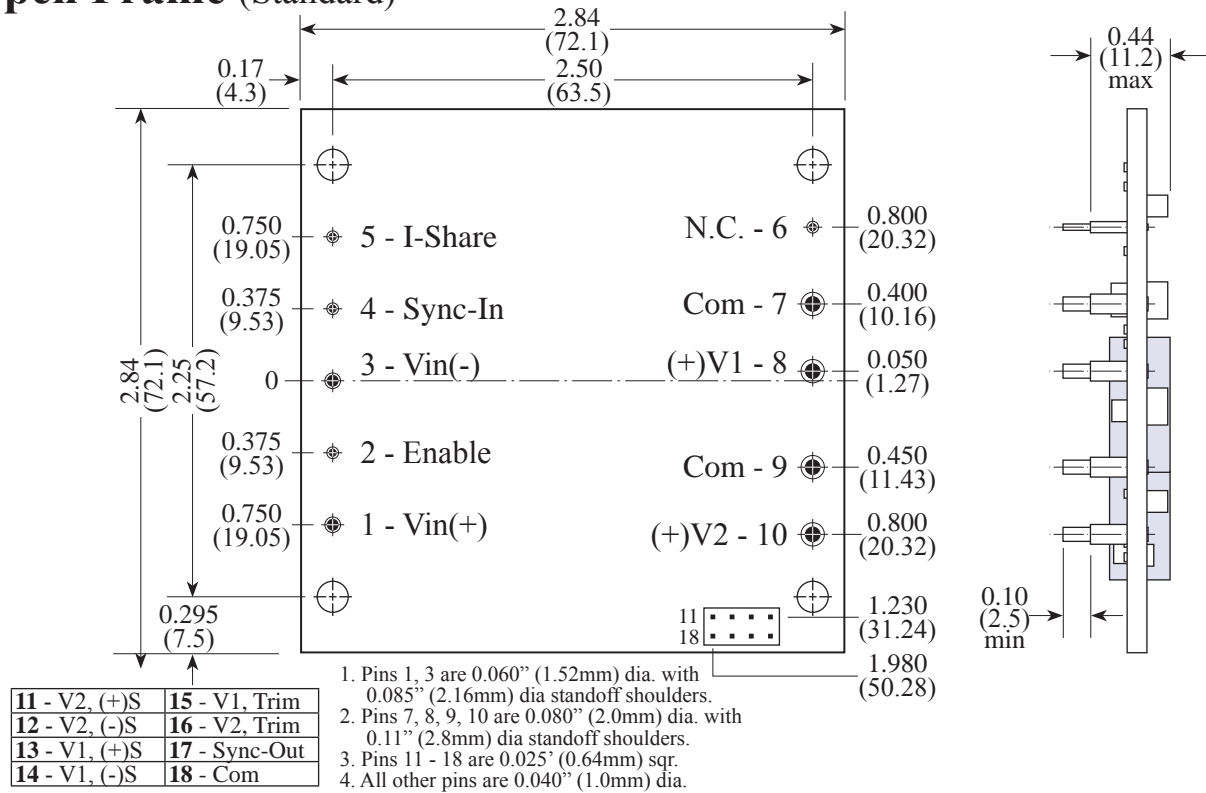

Encapsulated (Optional, MC Suffix)

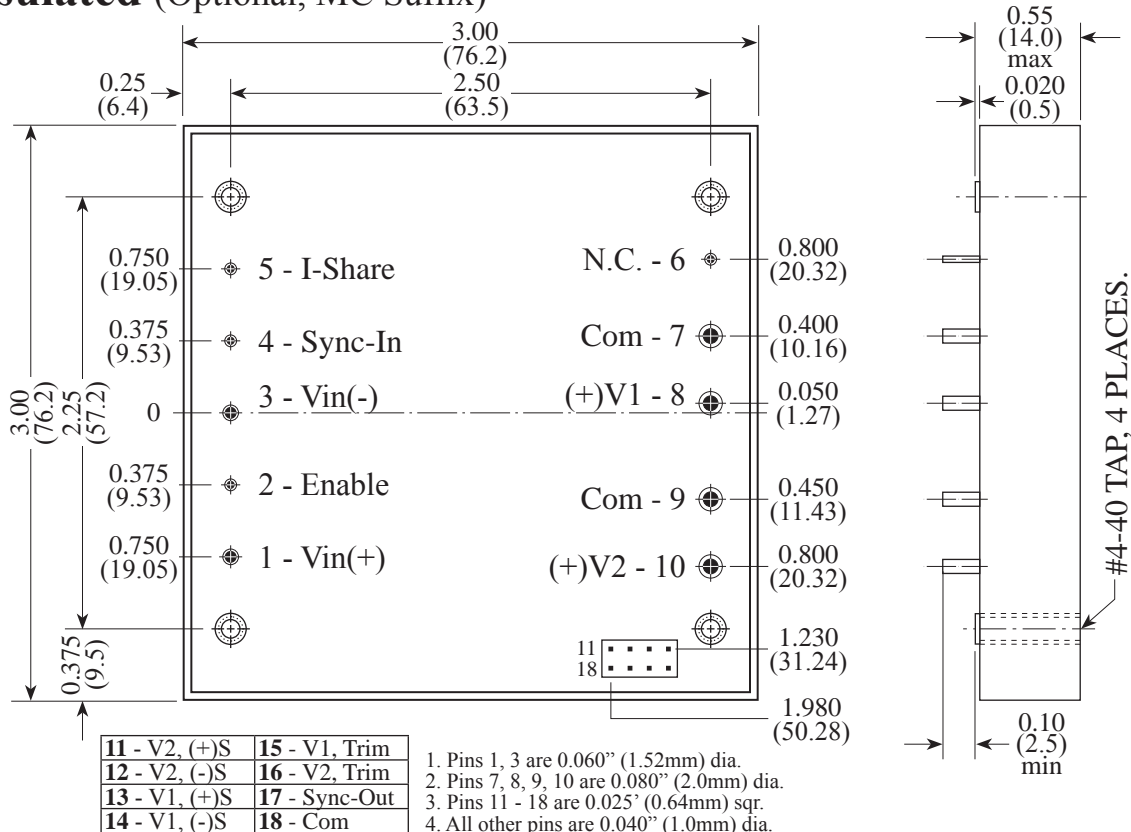

MK Series, Triple Output 130-150W

INPUT		OUTPUT											Over Temp. Shutdown /Recover	EFF. (typ.)	MODEL NO.								
Nominal (Range)	UVLO On/Off	Power (Watt)	Voltage (V)			Current (A)			Ripple & Noise		OVP (V)	Short Circuit Protection											
			#	Set Point	Min.*	Max.*	#	Min.	Max.	Peak-Peak	R.M.S.												
300V (240V - 420V)	239V/ 235V	130W	+3.3V	+V1	+3.40	+3.20	+3.50	+11	0	+40.0	75mV	15mV	3.9	Hi-cup Mode Indefinite	+105°C/ +95°C	86%	MK150T3H03325-13						
			+2.5V	+V2	+2.50	+2.45	+2.55	+12	0	+20.0	75mV	15mV											
			+13V	+V3	+13.00	+12.50	13.50	+13	+0.1	+3.0	120mV	25mV											
		130W	+3.3V	+V1	+3.40	+3.20	+3.50	+11	0	+40.0	75mV	15mV	3.9			Hi-cup Mode Indefinite	+105°C/ +95°C	86%	MK150T3H03318-13				
			+1.8V	+V2	+1.80	+1.82	+1.78	+12	0	+20.0	75mV	15mV											
			+13V	+V3	+13.00	+12.50	13.50	+13	+0.1	+3.0	120mV	25mV											
		150W	+5.0V	+V1	+5.10	+4.90	+5.20	+11	0	+30.0	75mV	15mV	5.9					Hi-cup Mode Indefinite	+105°C/ +95°C	89%	MK150T3H05033-15		
			+3.3V	+V2	+3.40	+3.20	+3.50	+12	0	+20.0	75mV	15mV											
			+15V	+V3	+15.00	+14.50	15.50	+13	+0.1	+3.0	120mV	25mV											
		150W	+5.0V	+V1	+5.10	+4.90	+5.20	+11	0	+30.0	75mV	15mV	5.9							Hi-cup Mode Indefinite	+105°C/ +95°C	88%	MK150T3H05025-15
			+2.5V	+V2	+2.550	+2.45	+3.50	+12	0	+20.0	75mV	15mV											
			+15V	+V3	+15.00	+14.50	15.50	+13	+0.1	+3.0	120mV	25mV											
150W	+5.0V	+V1	+5.10	+4.90	+5.20	+11	0	+30.0	75mV	15mV	5.9	Hi-cup Mode Indefinite	+105°C/ +95°C	87%	MK150T3H05018-15								
	+1.8V	+V2	+3.40	+3.20	+3.50	+12	0	+20.0	75mV	15mV													
	+15V	+V3	+15.00	+14.50	15.50	+13	+0.1	+3.0	120mV	25mV													

*Combined Line & Load Regulation.

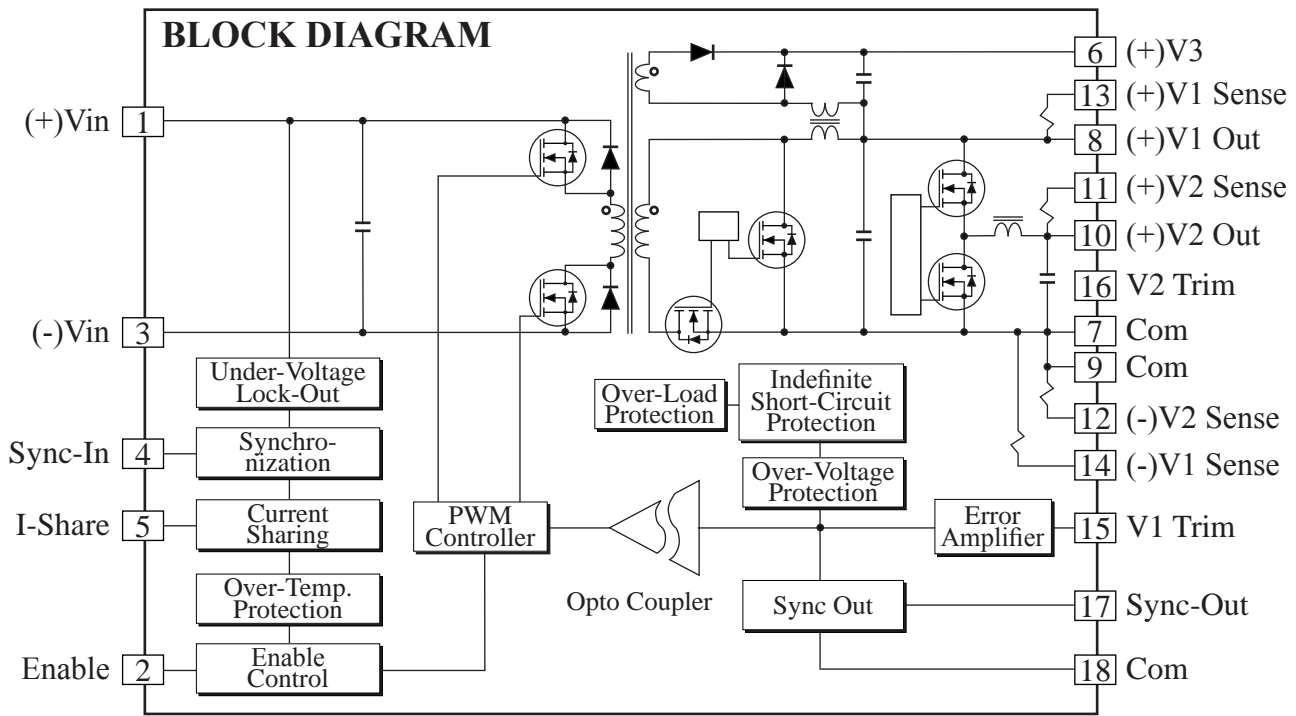

Sync-In :
(270KHz ~ 340KHz)

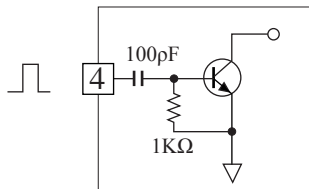

Sync-Out :

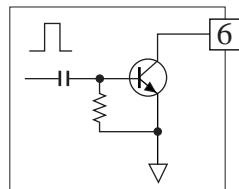

Power Good:

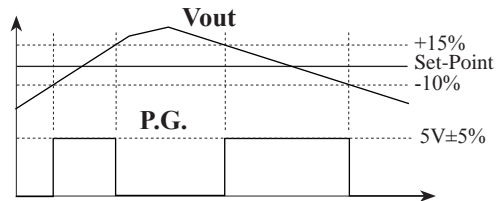

Product Numbering System & Selection Guide

MK	150	T	3H	050	33	- 15	C
Series No.	Output Power	No Output	Input Voltage	+V1 Output	+V2 Output	+V3 Output	Options
MK	150 : 130W to 150W	T : Triple	3H : 240-420V	033 : 3.3V 050 : 5.0V	18 : 1.8V 25 : 2.5V 33 : 3.3V	13 : 13V 15 : 15V	C : Extended Temperature MC : Encapsulated

MK Series, Triple Output 130-150W

Open Frame (Standard)

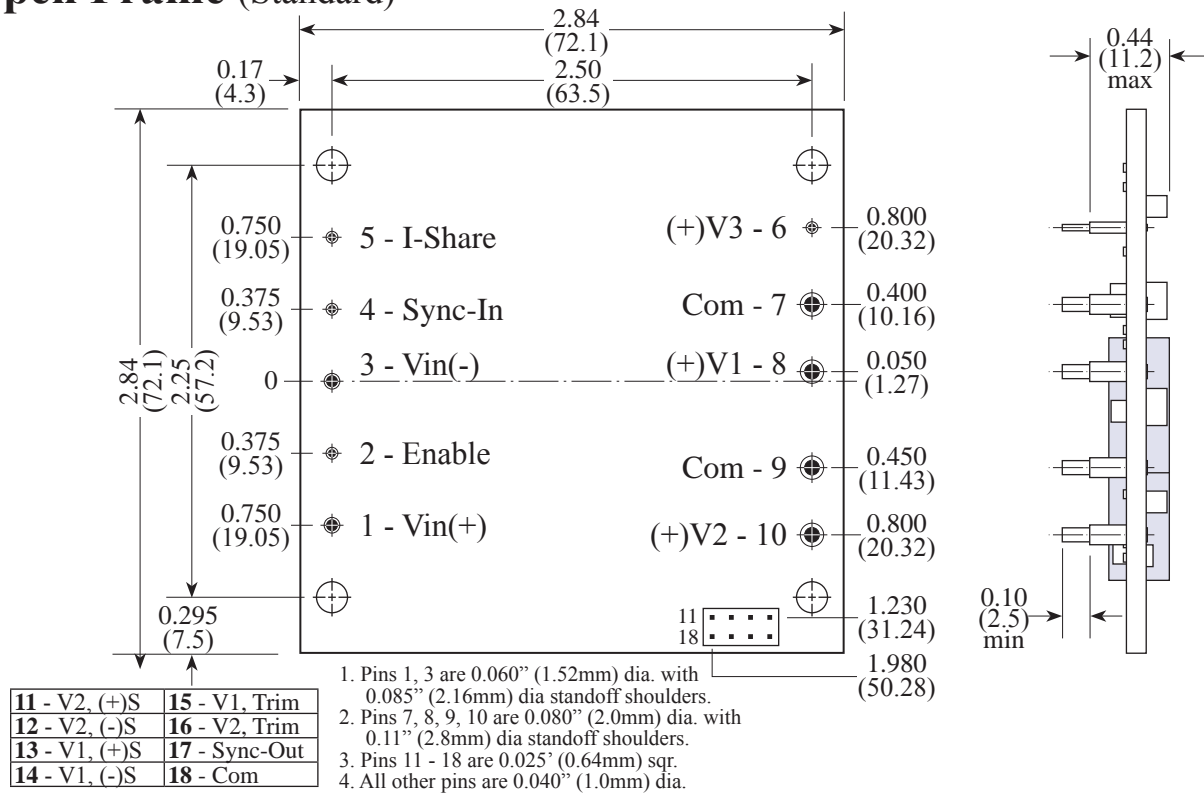

Encapsulated (Optional, MC Suffix)

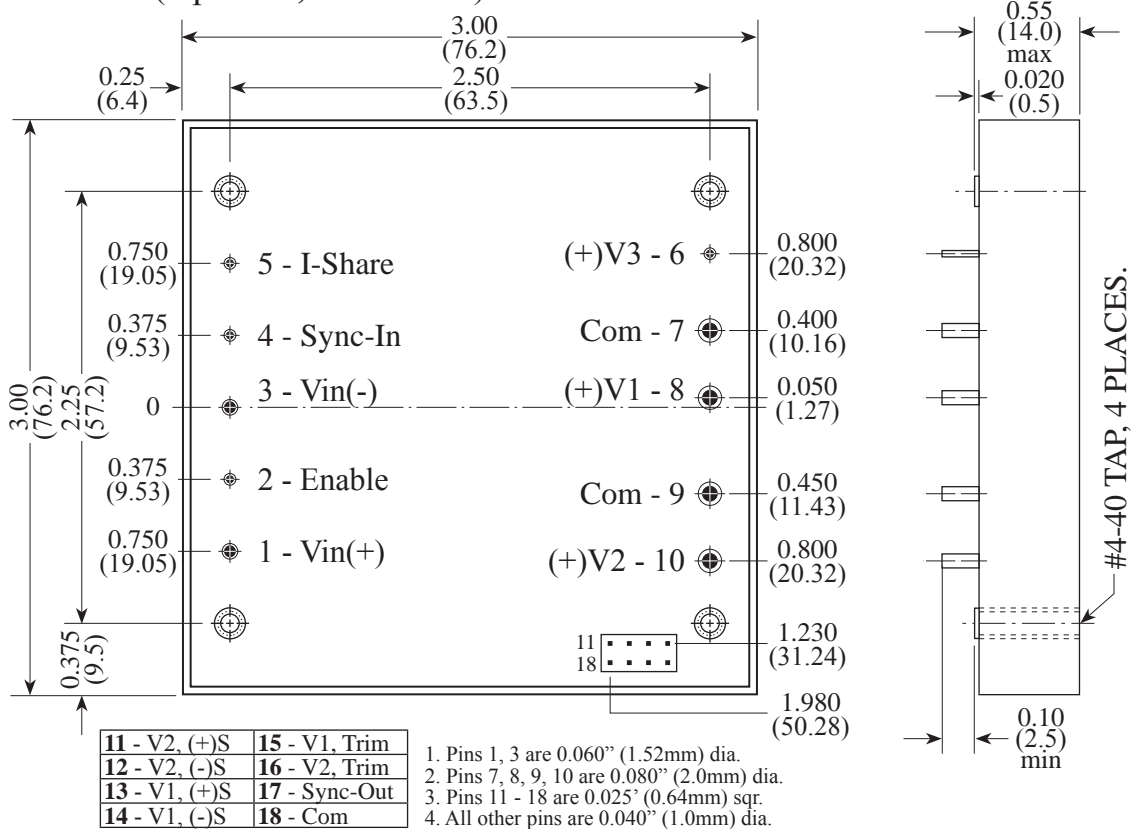

MK Series, Triple Output 130-150W

Parallel Operation

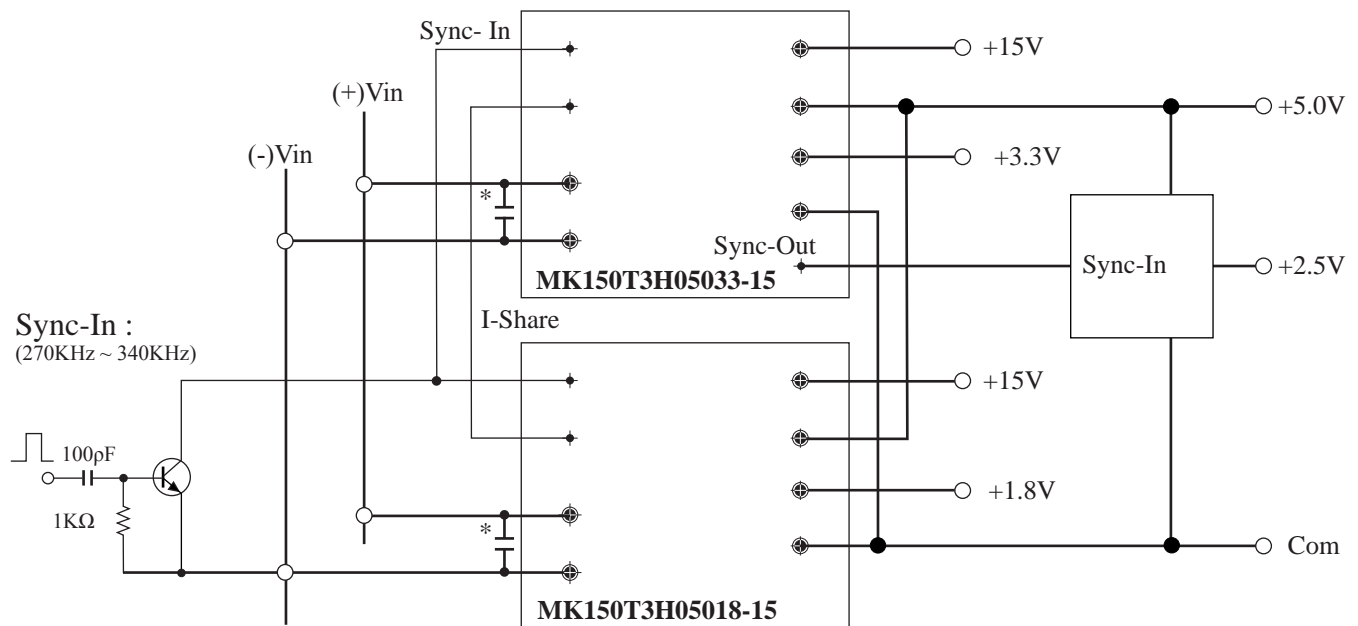

* External input capacitor is required if the power source located more than 3" away.

Enable

This pin provides the remote On/Off control function. Two control logics are available: Positive & Negative. Positive logic turns the module ON during a logic high voltage on the enable pin, and OFF during a logic low. Negative logic turns the module OFF during a logic high and ON during a logic low. Positive logic is the standard factory configuration. Negative Enable Logic can be specified with suffix N. The Enable pin can be left floating if not used.

Sync-In

This pin can be connected either to external clock or directly to the Sync-In pin of another MKS, MKD or MKT module. If the Sync-In pin is connected to another module's Sync-In pin, the connection should be as direct as possible, and the Vin(-) pins of the modules must be shorted together. If an external clock signal is applied to the Sync-In pin, the signal must be a 300KHz (± 30 KHz) square wave with a ≥ 4 Vp-p amplitude. The Sync-In pin can be left floating if not used.

I-Share

Two or more modules can be operated in parallel for either redundant operation or additional power requirements. Connect I-Share pin together will force load sharing between the connected modules. To implement forced load sharing, the Sync-In pins of all units must be connected together also. The I-Share pin can be left floating if not used.

Sync-Out

This pin contains a clock signal referenced to the (-)Vout pin. The frequency of this signal will equal either the module's internal clock frequency or the frequency established by an external clock applied to the Sync-In pin. The Sync-Out pin can be left floating if not used.

Sense

Remote sensing allows the converter to sense the output voltage directly at the point of load and thus automatically compensates the load conductor distribution & contact losses. There is one sense lead for each output terminal, designated +Sense and -Sense. These leads carry very low current compared with the load leads. Internally a resistor is connected between sense terminal and power output terminal. If the remote sense is not used, the sense leads need to be shorted to their respective output leads. Care has to be taken when making output connections. If the output terminals should disconnect before the sense lines, the full load current will flow down the sense lines and damage the internal sensing resistors. Be sure to always power down the converter before making any output connections. The maximum compensation voltage for line drop is up to 0.5V

Trim

Output voltage set-point can be increased or decreased by connecting a trimming resistor between trim pin and either the (+)Vout pin or the (-)Vout pin. The trim function is a negative logic. Connecting resistor from trim pin to (-)Vout will trim the voltage up. The trim pin can be left floating if not used.