

**FEATURES****General:**

- Size 3.0 x 4.60 x 0.60 in.  
(76.2 x 116.8 x 15.3 mm)
- Efficiency > 91%
- 600 watt or 800 watt output
- Load sharing to 20 units  
(16,000 watt output)
- Input range :  
180-340 or 360-460Vdc
- Open frame or Encapsulated
- Integral PCB transformer/inductor
- Line regulation  $\pm 0.2\%$
- Load regulation  $\pm 0.5\%$
- Fixed operating frequency

**Protection:**

- Output over-voltage protection
- Output over-load protection
- Hiccup mode short circuit protection
- Over-temperature protection
- Input under-voltage lock-out

**Control:**

- Enable (On/Off) Control
- Remote Sense
- Current Sharing
- Output voltage Trimming

**Isolation:**

- Isolation Voltage > 1500V

**APPLICATIONS**

- Distributed Power Systems
- Workstations
- Computer Equipment
- Communications Equipment

Load Sharing to 16,000 watts  
Capacitive Load 25,000  $\mu\text{F}$  each



**RKS** series is a family of 600W to 800W DC-DC converters with high power density, high efficiency, and high reliability. The wide input range is ideal for battery or unregulated input applications. Integral PCB transformer / inductor is used for all models in this series. This new design technique has greatly improved the magnetic coupling, reduced switching spike and provided performance consistency. It also streamlines the production process by completely eliminating the hand-wind magnetic assembly process from production lines.

**RKS** series provides the most extensive protection to safeguard both the power converter and the load. It includes output over-voltage protection, over-current protection, hiccup mode indefinite short circuit protection, under-voltage lockout and over-temperature protection. Over-current inception point is set at about 115% of rated load. Hiccup mode cycles at 28mSec period with 3mSec on and 25mSec off. Over-temperature shutdown activated at +115°C board temperature will recover when the temperature falls below +95°C.

**RKS** series features low output noise, very tight line and load regulation, and high efficiency. There is no external capacitor requirement for normal operation. Output trim pin is standard. Sense pins are provided on low output voltage models for line drop compensation.

### 1. Absolute Maximum Ratings

Stresses in excess of the absolute maximum ratings can cause performance degradation, adversely effect longterm reliability, and cause permanent damage to the device.

| Parameter                    | Input Designator / Description     | Min  | Max   | Units |
|------------------------------|------------------------------------|------|-------|-------|
| <b>Input Voltage</b>         |                                    |      |       |       |
| Continuous                   | 1H                                 | -0.3 | 190   | Vdc   |
|                              | 2H                                 | -0.3 | 350   | Vdc   |
|                              | 2WH                                | -0.3 | 430   | Vdc   |
|                              | 3H                                 | -0.3 | 430   | Vdc   |
|                              | 4H                                 | -0.3 | 470   | Vdc   |
| Transient<br>(100mSec.)      | 1H                                 | -0.3 | 200   | Vdc   |
|                              | 2H                                 | -0.3 | 360   | Vdc   |
|                              | 2WH                                | -0.3 | 440   | Vdc   |
|                              | 3H                                 | -0.3 | 440   | Vdc   |
|                              | 4H                                 | -0.3 | 470   | Vdc   |
| <b>Operating Temperature</b> | All models, base plate temperature | -40  | +105  | °C    |
| <b>Storage Temperature</b>   | <b>Ambient</b>                     | -55  | +125  | °C    |
| Isolation Voltage            | Input to Output                    |      | +2000 | Vdc   |

### 2. Input Specifications

| Parameter                            | Conditions / Description | Min | Nom | Max | Units |
|--------------------------------------|--------------------------|-----|-----|-----|-------|
| <b>Input Voltage</b>                 |                          |     |     |     |       |
| Voltage Range<br>(Continuous)        | 1H                       | 106 | 120 | 186 | Vdc   |
|                                      | 2H                       | 180 | 260 | 340 | Vdc   |
|                                      | 2WH                      | 180 | 300 | 420 | Vdc   |
|                                      | 3H                       | 240 | 320 | 420 | Vdc   |
|                                      | 4H                       | 360 | 420 | 460 | Vdc   |
| <b>Under-Voltage Lockout (UVLO)</b>  |                          |     |     |     |       |
| Turn-On Threshold<br>(Ramping Up)    | 1H                       |     | 104 |     | Vdc   |
|                                      | 2H                       |     | 178 |     | Vdc   |
|                                      | 2WH                      |     | 178 |     | Vdc   |
|                                      | 3H                       |     | 238 |     | Vdc   |
|                                      | 4H                       |     | 358 |     | Vdc   |
| Turn-Off Threshold<br>(Ramping Down) | 1H                       |     | 101 |     | Vdc   |
|                                      | 2H                       |     | 175 |     | Vdc   |
|                                      | 3H                       |     | 235 |     | Vdc   |
|                                      | 4H                       |     | 355 |     | Vdc   |

### 3. Enable (On-Off Control)

| Parameter                      | Conditions / Description | Min  | Nom | Max | Units |
|--------------------------------|--------------------------|------|-----|-----|-------|
| <b>Enable Pin</b>              |                          |      |     |     |       |
| Open Circuit Voltage           | Enable pin floating      |      | 10  |     | Vdc   |
| Source Current                 |                          |      |     | 1   | mA    |
| <b>Negative Logic</b>          |                          |      |     |     |       |
| Standard                       |                          |      |     |     |       |
| On-Control                     | Logic low                | -0.5 |     | 1.8 | Vdc   |
| Off-Control                    | Logic high or floating   | 2.5  |     | 10  | Vdc   |
| <b>Positive Logic</b>          |                          |      |     |     |       |
| Optional (Please add Suffix P) |                          |      |     |     |       |
| On-Control                     | Logic high or floating   | 2.5  |     | 10  | Vdc   |
| Off-Control                    | Logic low                | -0.5 |     | 1.8 | Vdc   |

### 4. Isolation Specifications

| Parameter                | Conditions / Description | Min  | Nom | Max | Units |
|--------------------------|--------------------------|------|-----|-----|-------|
| <b>Isolation Voltage</b> |                          |      |     |     |       |
| Input to Output          |                          | 1500 |     |     | Vdc   |
| I/O to Case              |                          | 500  |     |     | Vdc   |
| Isolation Resistance     | Input to Output          | 10   |     |     | MΩ    |
| Isolation Capacitance    | Input to Output          |      | 3   |     | nF    |

## 5. Output Specifications

| Parameter               | Conditions / Description   | Min | Nom | Max  | Units |
|-------------------------|----------------------------|-----|-----|------|-------|
| Voltage Accuracy        | Please see table           |     |     |      | %     |
| Output Current          | Please see table           |     |     |      | Adc   |
| Output Trim             |                            |     |     | ±10  | %Vout |
| Over Voltage Protection | Please see table           |     |     | 120  | %Vdc  |
| Line Regulation         |                            |     |     | ±0.1 | %Vout |
| Load Regulation         |                            |     |     | ±0.1 | %Vout |
| Transient Response      | 50% ± 25% step load change |     | 200 |      | µSec. |
| Ripple & Noise          | Please see table           |     |     |      | mVp-p |
| Switching Frequency     |                            |     | 200 |      | KHz   |

## 6. Output Trim

| Parameter            | Conditions / Description         | Min | Nom | Max | Units |
|----------------------|----------------------------------|-----|-----|-----|-------|
| <b>Positive Trim</b> | Standard                         |     |     |     |       |
| Trim Up              | Trim Pin to (+)Sense             |     |     | 10  | %Vdc  |
| Trim Down            | Trim Pin to (-)Sense             | 10  |     |     | %Vdc  |
| <b>Negative Trim</b> | Optional - (Please Add Suffix N) |     |     |     |       |
| Trim Up              | Trim Pin to (-)Sense             |     |     | 10  | %Vdc  |
| Trim Down            | Trim Pin to (+)sense             | 10  |     |     | %Vdc  |

\* Trim pin can be left floating if not used.

## 7. Environmental and Mechanical Specifications

| Parameter               | Conditions / Description                      | Min | Nom     | Max   | Units |
|-------------------------|---|-----|---------|-------|-------|
| Operating Temperature   | PCB Temperature                               |     |         |       |       |
| Standard                |   | -40 |         | +100  | °C    |
| Extended                |   | -55 |         | +100  | °C    |
| Storage Temperature     |   | -55 |         | +125  | °C    |
| Temperature Coefficient |   |     |         | ±0.02 | %/°C  |
| Shock                   | Halfsine wave, 3 axes                         | 50  |         |       | g     |
| Sinusoidal Vibration    | GR-63-CORE, Section 5.4.2                     | 1   |         |       | g     |
| Humidity                | Relative Humidity, Non-Condensing             |     |         | 95    | %R.H. |
| Weight                  |   |     |         |       |       |
| Open Frame              |   |     | 10(280) |       | Oz(g) |
| Encapsulated            |   |     | 16(454) |       | Oz(g) |
| MTBF (calculated)       | Bellcore TR-NWT-000332 method 1 - parts count | 1   |         |       | MHrs  |

## 8. Protections

| Parameter                          | Conditions / Description                   | Min | Nom  | Max | Units |
|------------------------------------|--|-----|------|-----|-------|
| <b>Over-Load Protection</b>        |  |     |      |     |       |
| Type                               | Current-Mode, Pulse by Pulse Current Limit |     |      |     |       |
| Threshold                          | % Rated Load                               |     | 120  |     | %     |
| <b>Short-Circuit Protection</b>    | Main Output                                |     |      |     |       |
| Type                               | Hiccup Mode, Non-Latching, Auto-Recovery   |     |      |     |       |
| Threshold                          | Short-Circuit Resistance                   |     |      | 65  | mΩ    |
| <b>Short-Circuit Protection</b>    | Auxilliary Outputs                         |     |      |     |       |
| Type                               | Current Limit, Non-Latching, Auto-Recovery |     |      |     |       |
| <b>Over-Temperature Protection</b> |  |     |      |     |       |
| Type                               | Non-Latching, Auto-Recovery                |     |      |     |       |
| Threshold                          | PCB Temperature                            |     | +115 |     | °C    |
| Hysteresis                         |  |     | 15   |     | °C    |
| <b>Over-Voltage Protection</b>     |  |     |      |     |       |
| Type                               | Auxiliary Feedback Loop Control            |     |      |     |       |
| Set-Point                          |  |     |      | 120 | %Vout |

**Block Diagram:**

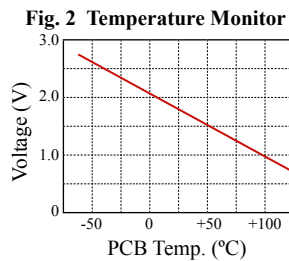
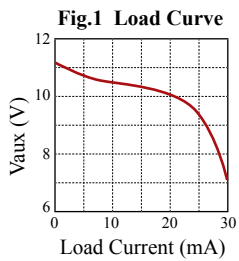
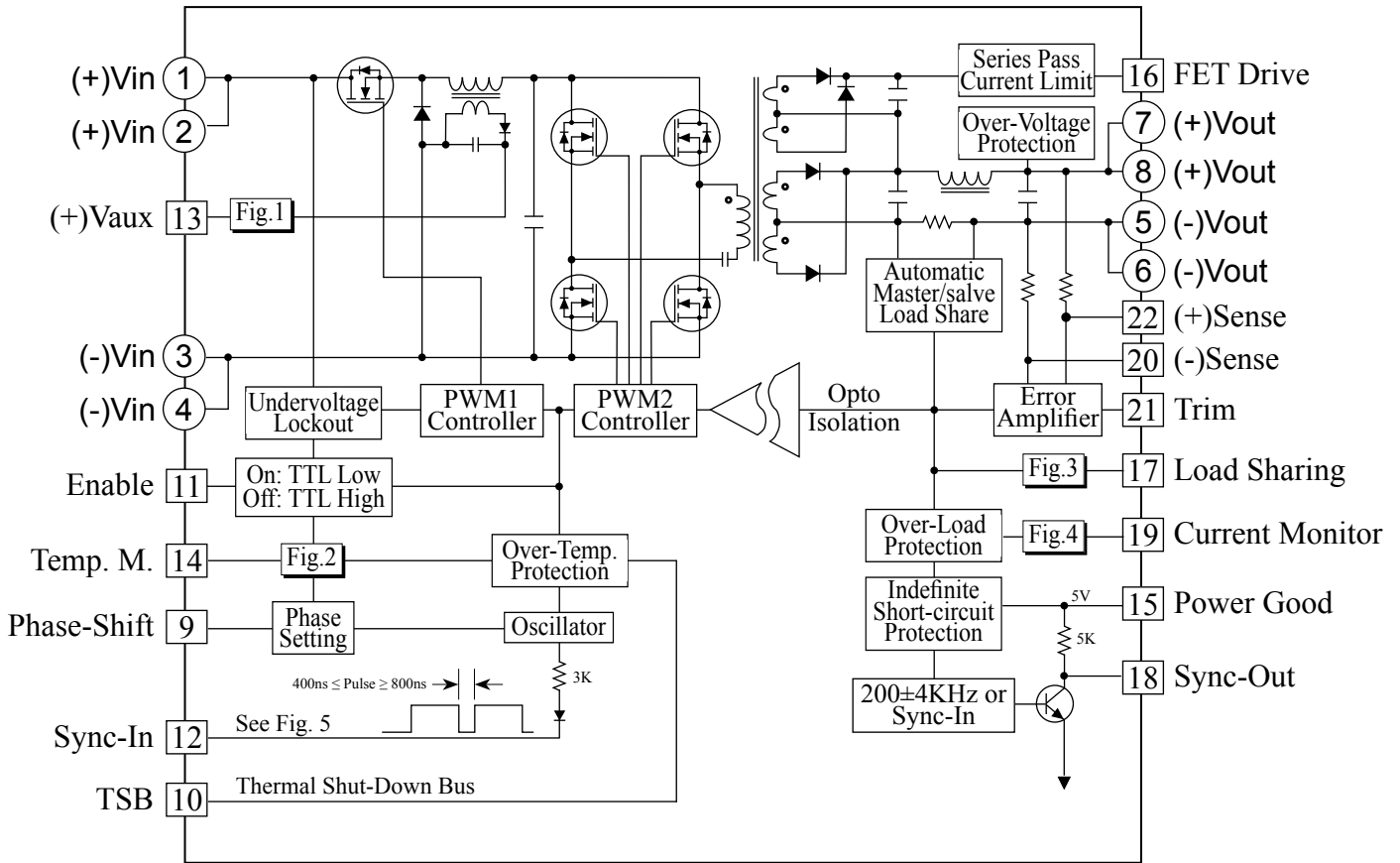

**Fig. 5 External Sync (180 - 280 KHz)**

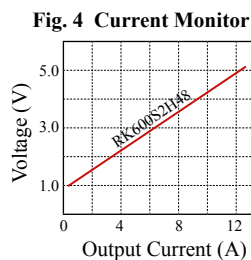
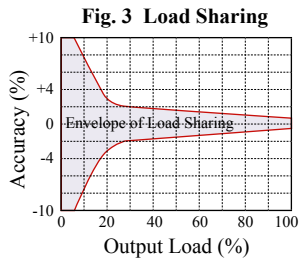
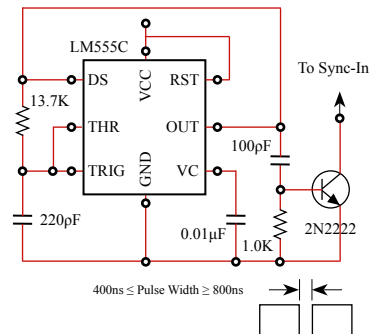

**Mechanical Specifications:**

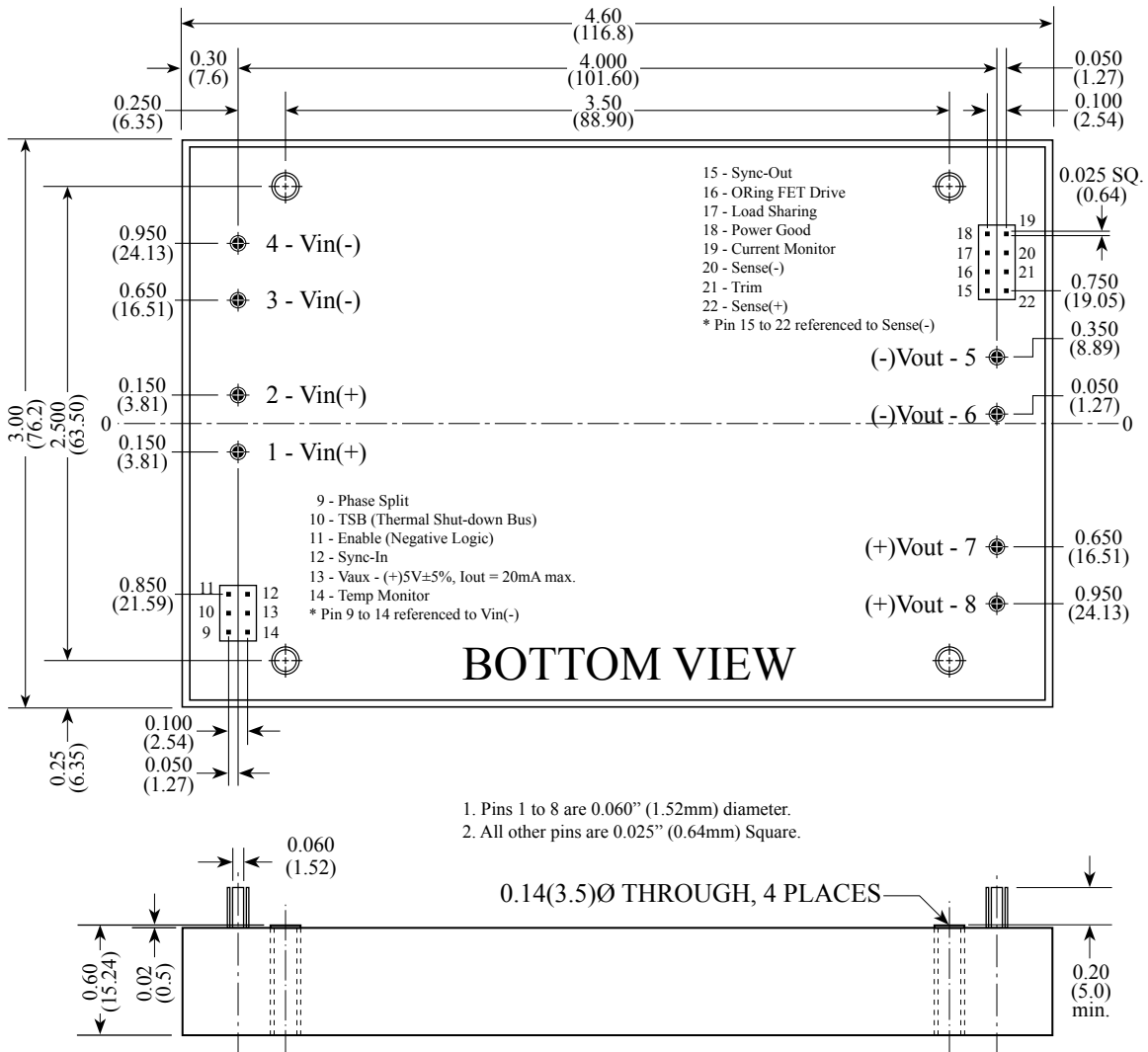

**Product Numbering System & Selection Guide**

| Series No. | Output Power                           | No Output         | Input Voltage         | Output Voltage  | Options                     |
|------------|--|-------------------|-----------------------|-----------------|-----------------------------|
| <b>RK</b>  | <b>600</b> : 600W<br><b>800</b> : 800W | <b>S</b> : Single | <b>2H</b> : 180-340V  | <b>24</b> : 24V | <b>MC</b> : -55°C Operation |
|            |  |                   | <b>1H</b> : 106-186V  | <b>12</b> : 12V |                             |
|            |  |                   | <b>2HW</b> : 180-420V | <b>15</b> : 15V |                             |
|            |  |                   | <b>3H</b> : 240-420V  | <b>28</b> : 28V |                             |
|            |  |                   | <b>4H</b> : 360-460V  | <b>36</b> : 36V |                             |
|            |  |                   |                       | <b>48</b> : 48V |                             |
|            |  |                   |                       | <b>52</b> : 52V |                             |
|            |  |                   |                       | <b>60</b> : 60V |                             |

| INPUT                          |                              |       | OUTPUT            |             |       |       |             |       |                       |            |            |                        | Over Temp. Shutdown /Recover | EFF. (typ.) | MODEL NO.   |
|--------------------------------|------------------------------|-------|-------------------|-------------|-------|-------|-------------|-------|-----------------------|------------|------------|------------------------|------------------------------|-------------|-------------|
| Range Designator (Range Vdc)   | Under Voltage Lockout (typ.) |       | Max. Power (Watt) | Voltage (V) |       |       | Current (A) |       | Ripple & Noise (typ.) |            | OVP (max.) | Capacitive Load (max.) |                              |             |             |
|                                | On                           | Off   |                   | Set Point   | Min.  | Max.  | Min.        | Max.  | Peak-Peak             | RMS        |            |                        |                              |             |             |
| 2H<br>(180-340)                | 178                          | 175   | 600W              | 12          | 11.85 | 12.15 | 2.5         | 50    | 120mV                 | 30mV       | 14.4V      | 25,000<br>µF           | +115°C/<br>+95°C             | 88%         | RK600S2H12  |
|                                |                              |       | 800W              |             |       |       | 3.0         | 67    | 120mV                 | 30mV       | 14.4V      |                        |                              | 88%         | RK800S2H12  |
|                                |                              |       | 600W              | 15          | 14.80 | 15.20 | 2.0         | 40    | 150mV                 | 35mV       | 18.0V      |                        |                              | 88%         | RK600S2H15  |
|                                |                              |       | 800W              |             |       |       | 2.5         | 54    | 150mV                 | 35mV       | 18.0V      |                        |                              | 88%         | RK800S2H15  |
|                                |                              |       | 600W              | 24          | 23.70 | 24.30 | 0.5         | 25.0  | 240mV                 | 60mV       | 28.8V      |                        |                              | 90%         | RK600S2H24  |
|                                |                              |       | 800W              |             |       |       | 0.5         | 33.4  | 240mV                 | 60mV       | 28.8V      |                        |                              | 90%         | RK800S2H24  |
|                                |                              |       | 600W              | 28          | 27.70 | 28.30 | 0.5         | 21.4  | 280mV                 | 70mV       | 33.6V      |                        |                              | 90%         | RK600S2H28  |
|                                |                              |       | 800W              |             |       |       | 0.5         | 28.6  | 280mV                 | 70mV       | 33.6V      |                        |                              | 90%         | RK800S2H28  |
|                                |                              |       | 600W              | 48          | 47.60 | 48.40 | 0.2         | 12.5  | 480mV                 | 120mV      | 57.6V      |                        |                              | 90%         | RK600S2H48  |
|                                |                              |       | 800W              |             |       |       | 0.2         | 16.7  | 480mV                 | 120mV      | 57.6V      |                        |                              | 90%         | RK800S2H48  |
|                                |                              |       | 600W              | 52          | 51.50 | 52.50 | 0.2         | 11.5  | 520mV                 | 130mV      | 62.4V      |                        |                              | 91%         | RK600S2H52  |
|                                |                              |       | 800W              |             |       |       | 0.2         | 15.4  | 520mV                 | 130mV      | 62.4V      |                        |                              | 91%         | RK800S2H52  |
| 2HW<br>(180-420)               | 178                          | 175   | 600W              | 12          | 11.85 | 12.15 | 2.5         | 50    | 120mV                 | 30mV       | 14.4V      | 25,000<br>µF           | +115°C/<br>+95°C             | 86%         | RK600S2HW12 |
|                                |                              |       | 800W              |             |       |       | 3.0         | 67    | 120mV                 | 30mV       | 14.5V      |                        |                              | 86%         | RK800S2HW12 |
|                                |                              |       | 600W              | 15          | 14.80 | 15.20 | 2.0         | 40    | 150mV                 | 35mV       | 18.0V      |                        |                              | 86%         | RK600S2HW15 |
|                                |                              |       | 800W              |             |       |       | 2.5         | 54    | 150mV                 | 35mV       | 18.0V      |                        |                              | 88%         | RK800S2HW15 |
|                                |                              |       | 600W              | 24          | 23.70 | 24.30 | 0.5         | 25.0  | 240mV                 | 60mV       | 28.8V      |                        |                              | 88%         | RK600S2HW24 |
|                                |                              |       | 800W              |             |       |       | 0.5         | 33.4  | 240mV                 | 60mV       | 28.8V      |                        |                              | 88%         | RK800S2HW24 |
|                                |                              |       | 600W              | 28          | 27.70 | 28.30 | 0.5         | 21.4  | 280mV                 | 70mV       | 33.6V      |                        |                              | 88%         | RK600S2HW28 |
|                                |                              |       | 800W              |             |       |       | 0.5         | 28.6  | 280mV                 | 70mV       | 33.6V      |                        |                              | 88%         | RK800S2HW28 |
|                                |                              |       | 600W              | 48          | 47.60 | 48.40 | 0.2         | 12.5  | 480mV                 | 120mV      | 57.6V      |                        |                              | 88%         | RK600S2HW48 |
|                                |                              |       | 800W              |             |       |       | 0.2         | 16.7  | 480mV                 | 120mV      | 57.6V      |                        |                              | 88%         | RK800S2HW48 |
|                                |                              |       | 600W              | 52          | 51.50 | 52.50 | 0.2         | 11.5  | 520mV                 | 130mV      | 62.4V      |                        |                              | 88%         | RK600S2HW52 |
|                                |                              |       | 800W              |             |       |       | 0.2         | 15.4  | 520mV                 | 130mV      | 62.4V      |                        |                              | 88%         | RK800S2HW52 |
| 3H<br>(240-420)                | 238                          | 235   | 600W              | 12          | 11.85 | 12.15 | 2.5         | 50    | 120mV                 | 30mV       | 14.4V      | 25,000<br>µF           | +115°C/<br>+95°C             | 88%         | RK600S3H12  |
|                                |                              |       | 800W              |             |       |       | 3.0         | 67    | 120mV                 | 30mV       | 14.5V      |                        |                              | 88%         | RK800S3H12  |
|                                |                              |       | 600W              | 15          | 14.80 | 15.20 | 2.0         | 40    | 150mV                 | 35mV       | 18.0V      |                        |                              | 88%         | RK600S3H15  |
|                                |                              |       | 800W              |             |       |       | 2.5         | 54    | 150mV                 | 35mV       | 18.0V      |                        |                              | 88%         | RK800S3H15  |
|                                |                              |       | 600W              | 24          | 23.70 | 24.30 | 0.5         | 25.0  | 240mV                 | 60mV       | 28.8V      |                        |                              | 90%         | RK600S3H24  |
|                                |                              |       | 800W              |             |       |       | 0.5         | 33.4  | 240mV                 | 60mV       | 28.8V      |                        |                              | 90%         | RK800S3H24  |
|                                |                              |       | 600W              | 28          | 27.70 | 28.30 | 0.5         | 21.4  | 280mV                 | 70mV       | 33.6V      |                        |                              | 90%         | RK600S3H28  |
|                                |                              |       | 800W              |             |       |       | 0.5         | 28.6  | 280mV                 | 70mV       | 33.6V      |                        |                              | 90%         | RK800S3H28  |
|                                |                              |       | 600W              | 36          | 35.60 | 36.40 | 0.5         | 16.7  | 360mV                 | 90mV       | 43.2V      |                        |                              | 90%         | RK600S3H36  |
|                                |                              |       | 800W              |             |       |       | 0.5         | 22.2  | 360mV                 | 90mV       | 43.2V      |                        |                              | 90%         | RK800S3H36  |
|                                |                              |       | 600W              | 48          | 47.60 | 48.40 | 0.2         | 12.5  | 480mV                 | 120mV      | 57.6V      |                        |                              | 90%         | RK600S3H48  |
|                                |                              |       | 800W              |             |       |       | 0.2         | 16.7  | 480mV                 | 120mV      | 57.6V      |                        |                              | 90%         | RK800S3H48  |
| 600W                           | 52                           | 51.50 | 52.50             | 0.2         | 11.5  | 520mV | 130mV       | 62.4V | 91%                   | RK600S3H52 |            |                        |                              |             |             |
| 800W                           |                              |       |                   | 0.2         | 15.4  | 520mV | 130mV       | 62.4V | 91%                   | RK800S3H52 |            |                        |                              |             |             |
| 600W                           | 60                           | 59.50 | 60.50             | 0.2         | 10.0  | 600mV | 150mV       | 72V   | 91%                   | RK600S3H60 |            |                        |                              |             |             |
| 800W                           |                              |       |                   | 0.2         | 13.4  | 600mV | 150mV       | 72V   | 91%                   | RK800S3H60 |            |                        |                              |             |             |
| 4H<br>(360-460)<br>- PFC input | 358                          | 355   | 600W              | 12          | 11.85 | 12.15 | 2.5         | 50    | 120mV                 | 30mV       | 14.4V      | 25,000<br>µF           | +115°C/<br>+95°C             | 90%         | RK600S4H12  |
|                                |                              |       | 800W              |             |       |       | 3.0         | 67    | 120mV                 | 30mV       | 14.4V      |                        |                              | 90%         | RK800S4H12  |
|                                |                              |       | 600W              | 15          | 14.80 | 15.20 | 2.0         | 40    | 150mV                 | 35mV       | 18.0V      |                        |                              | 90%         | RK600S4H15  |
|                                |                              |       | 800W              |             |       |       | 2.5         | 54    | 150mV                 | 35mV       | 18.0V      |                        |                              | 90%         | RK800S4H15  |
|                                |                              |       | 600W              | 24          | 23.70 | 24.30 | 0.5         | 25.0  | 240mV                 | 60mV       | 28.8V      |                        |                              | 90%         | RK600S4H24  |
|                                |                              |       | 800W              |             |       |       | 0.5         | 33.4  | 240mV                 | 60mV       | 28.8V      |                        |                              | 90%         | RK800S4H24  |
|                                |                              |       | 600W              | 28          | 27.70 | 28.30 | 0.5         | 21.4  | 280mV                 | 70mV       | 33.6V      |                        |                              | 90%         | RK600S4H28  |
|                                |                              |       | 800W              |             |       |       | 0.5         | 28.6  | 280mV                 | 70mV       | 33.6V      |                        |                              | 90%         | RK800S4H28  |
|                                |                              |       | 600W              | 48          | 47.60 | 48.40 | 0.2         | 12.5  | 480mV                 | 120mV      | 57.6V      |                        |                              | 90%         | RK600S4H48  |
|                                |                              |       | 800W              |             |       |       | 0.2         | 16.7  | 480mV                 | 120mV      | 57.6V      |                        |                              | 90%         | RK800S4H48  |
|                                |                              |       | 600W              | 52          | 51.50 | 52.50 | 0.2         | 11.5  | 520mV                 | 130mV      | 62.4V      |                        |                              | 90%         | RK600S4H52  |
|                                |                              |       | 800W              |             |       |       | 0.2         | 15.4  | 520mV                 | 130mV      | 62.4V      |                        |                              | 90%         | RK800S4H52  |

\* Please consult factory for other input and output combinations.

# Specifications are subjected to change without notice.

### **Phase-Shift**

Groups of DC-DC converters can be programmed to operate in different phases to reduce the input reflected ripple current and to reduce the load transient response time as well. The desired phase can be program by connecting a resistor from Phase Shift pin to vin(-). Some programming resistances are not standard values, provision for trimming is recommended. The resistor selection table is on p.6.

### **Enable (On/Off) Control**

The Enable pin allows the power module to be switched on and off electronically. The Enable (On/Off) function is useful for conserving battery power, for pulsed power application or for power up sequencing.

The Enable pin is referenced to the -Vin. It is pulled up internally, so no external voltage source is required. An open collector (or open drain) switch is recommended for controlling the Enable pin.

When using the Enable pin, make sure that the reference is really the -Vin pin, not ahead of EMI filtering, or remotely from the unit. Optically coupling the control signal and locating the opto coupler directly at the module will avoid any problems.

Two control logics are available: Positive & Negative. Positive logic turns the module ON during a logic high voltage on the enable pin, and OFF during a logic low. Negative logic turns the module OFF during a logic high and ON during a logic low. Negative logic is the standard factory configuration. Positive Enable Logic can be specified with suffix P.

If the Enable pin is not used, it can be left floating (positive logic), or connected to the -Vin pin (negative logic).

### **Sync-In**

The operating frequency is set to 200KHz and can be synchronized by an external clock connected between the Sync-In pin and ground (-)Vin. The clock frequency must be within the range of 180KHz to 280KHz, and the clock must be able to pull the Sync-In pin down greater than 400ns but less than 800ns. The *Sync-In* pin can be left floating if not used.

### **Temp. Monitor**

The converter internal (printed circuit board) temperature can be measured from this pin. The temperature slope is -10.9mV/°C, ±0.2% typ and the temperature range is -50°C (2.6V) to +125°C (0.71V).

### **Load-Sharing (LS)**

Two or more modules can be operated in parallel for either redundant operation or additional power requirements. Connecting *Load-Sharing* pins together will force load (current) sharing between the connected modules.

The *Load-Sharing* pin can be left floating if not used.

The load sharing accuracy is load dependant and the correlation is listed below:

- ±8.0% @ 10% load
- ±2.5% @ 20% load
- ±1.5% @ 50% load
- ±1.0% @ 90% load

### **Sync-Out**

This pin contains a clock signal referenced to the Sense(-) pin. The frequency of this signal will be twice of either the module's internal clock frequency or the frequency established by an external clock applied to the Sync-In pin. The *Sync-Out* pin can be left floating if not used.

### **Power Good (PG)**

The *Power Good* pin indicates the operating state of the module. A high voltage (5V) indicates that the Vout is within +15%/-10% of voltage set-point. A low voltage (< 1.0V) indicates that the Vout is out of regulation. The PG pin is referenced to the Sense(-) and can be left floating if not used.

### **ORing FET Drive (OD)**

The *FET Drive* pin provides a DC voltage of about 10V above the main output. It is suitable for driving an external ORing FET in series with the (+)Vout. This allows for OR-ing the outputs in redundant operation or in turn-on sequencing operation. The *ORing FET Drive* pin is referenced to the Sense(-) and can be left floating if not used.

### **Current Monitor**

Output current can be measured from this pin. The current range is min. load (1.0V) to full load (5.0V). The *Current Monitor* pin is referenced to the Sense(-) and can be left floating if not used.

### **Output Voltage Trim**

Output voltage can be adjusted up or down with an external resistor, and only negative trim logic is available. The output voltage will increase when an external trimming resistor is connected between the Trim pin and the (-)Vout/(-)Sense pin. The output voltage will decrease when an external trimming resistor is connected between *Trim* and (+)Vout/(-)Sense pin.

### **Remote Sensing**

Remote sensing allows the converter to sense the output voltage directly at the point of load and thus automatically compensates the load conductor distribution & contact losses. There is one sense lead for each output terminal, designated as Sense(+) and Sense(-). These leads carry very low current compared with the load leads. Internally a resistor is connected between sense terminal and power output terminal. If the remote sense is not used or modules are operated in load sharing, the sense leads needs to be shorted to their respective output leads.

Care has to be taken when making output connections. If the output terminals should disconnect before the sense lines, the full load current will flow down the sense lines and damage the internal sensing resistors. Be sure to always power down the converter before making any output connections. The maximum compensation voltage for line drop is up to 0.5V.

### **TSB (Thermal Shut-Down Bus)**

The voltage at TSB pin is logic low during normal operation and rises to 1.8v ~ 2.5v when the module internal over-temperature protection circuit activated. An external voltage (1.8v to 2.5v) applied on the module TSB pin will disable the module operation.

All TSB pins need to be connected together for load sharing application. All modules will be disabled if any one module is running into thermal protection mode.



**Phase Shift :**

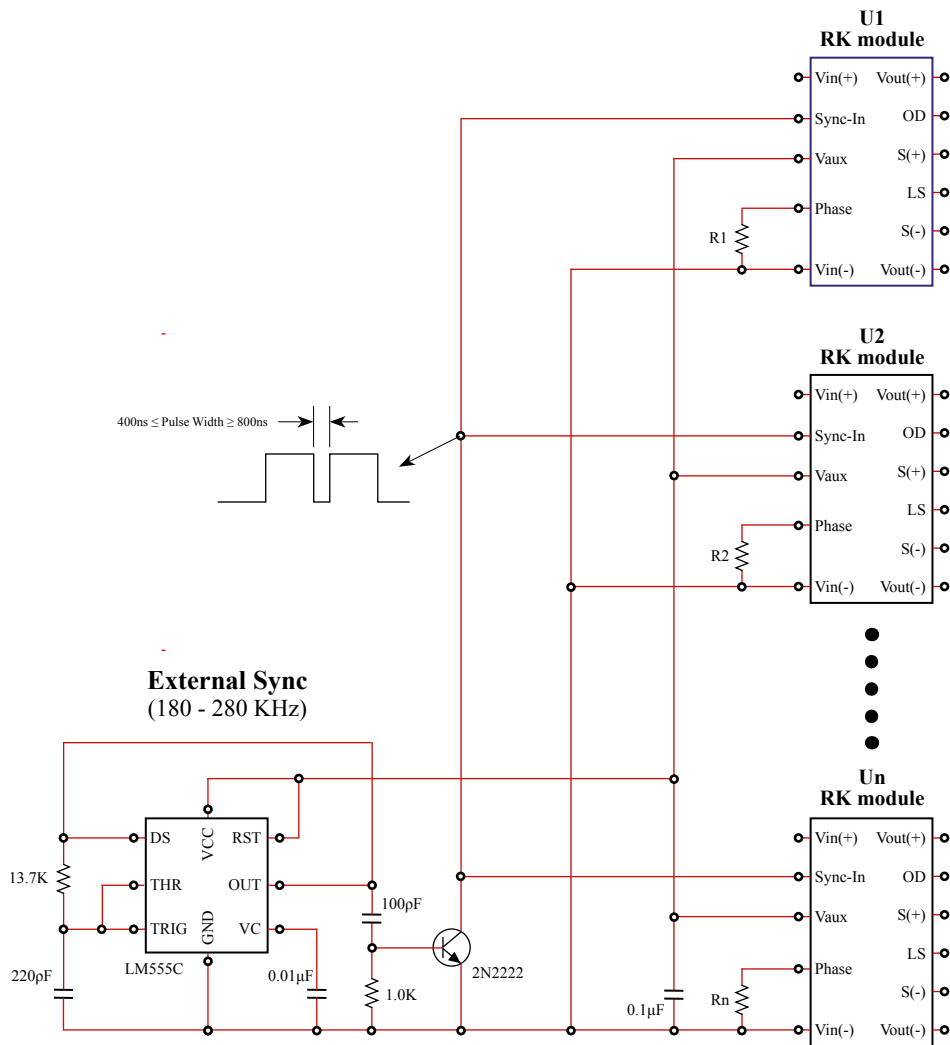

| Phase :    | 0°   | 90°    | 120°  | 180°  | 240°  | 270°  | 360° |
|------------|------|--------|-------|-------|-------|-------|------|
| Resistor : | Open | Jumper | 4.34K | 17.1K | 43.9K | 76.7K | Open |

\* Please make provision pads for resistor trimming on your pcb to accomodate any non-standard resistance value.

**Enable Control :**

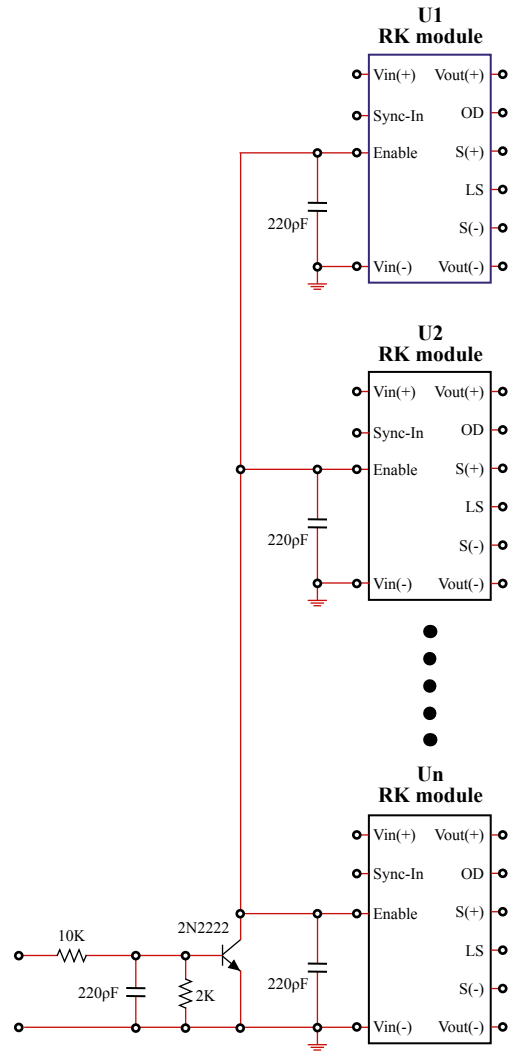
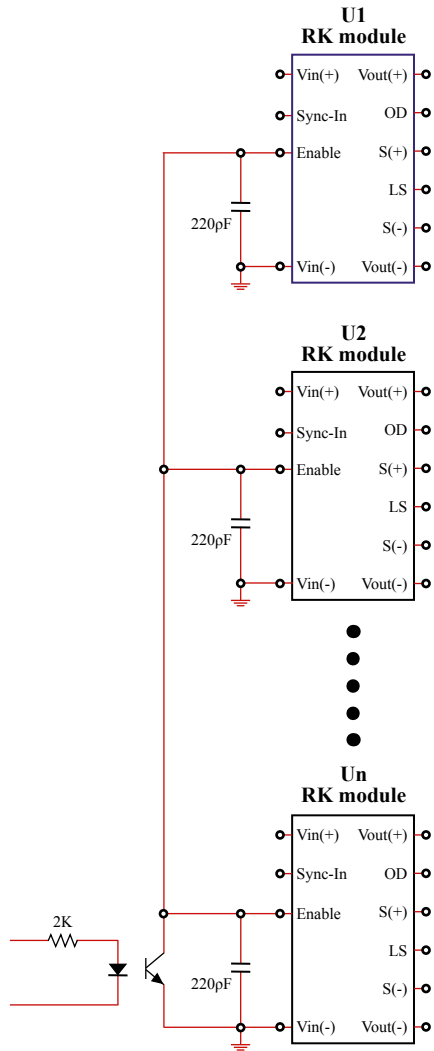

**Power Good & ORing FET Drive :**

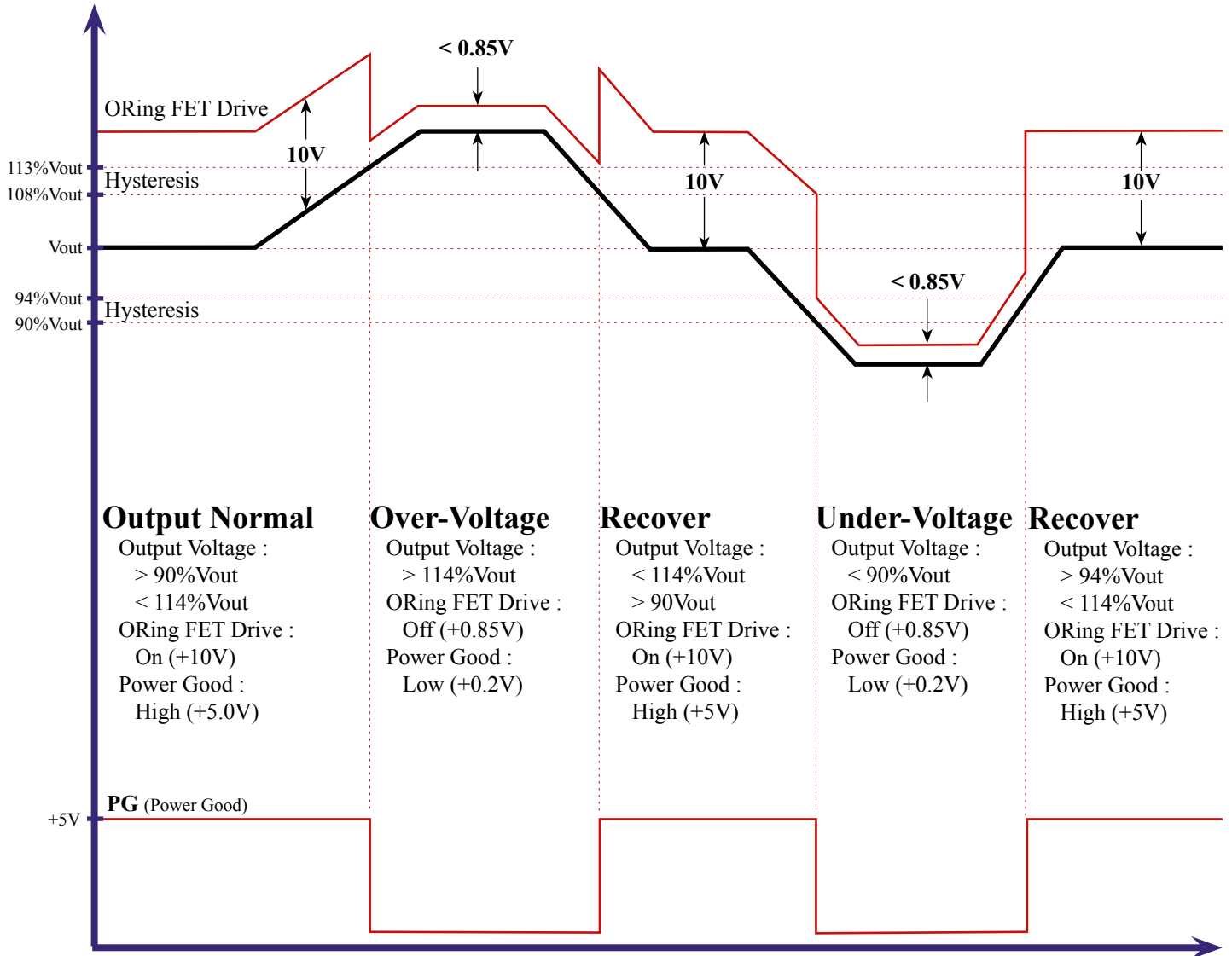

**Efficiency (typ)**

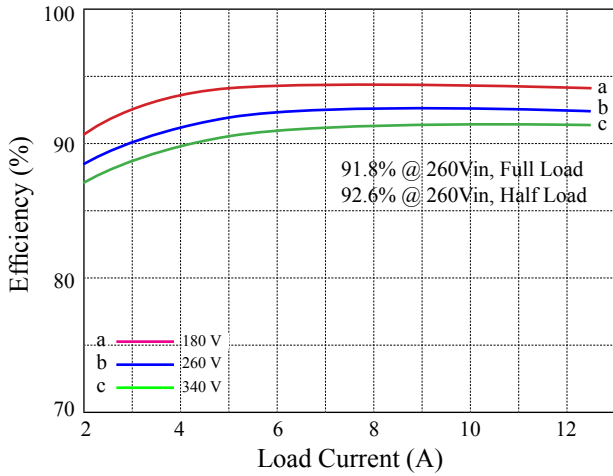

**Output Ripple/Noise (typ)**

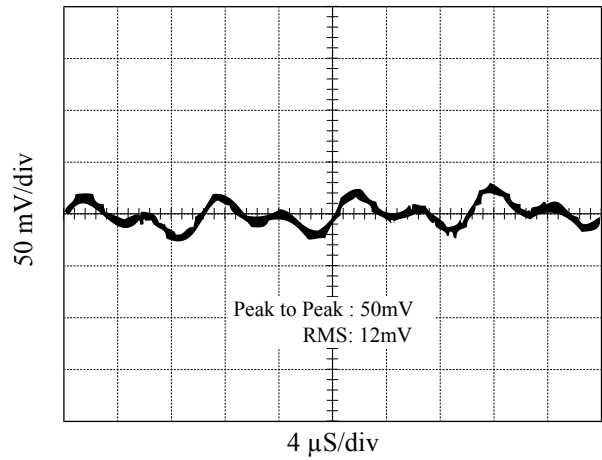

**Load Transient Response (typ)**

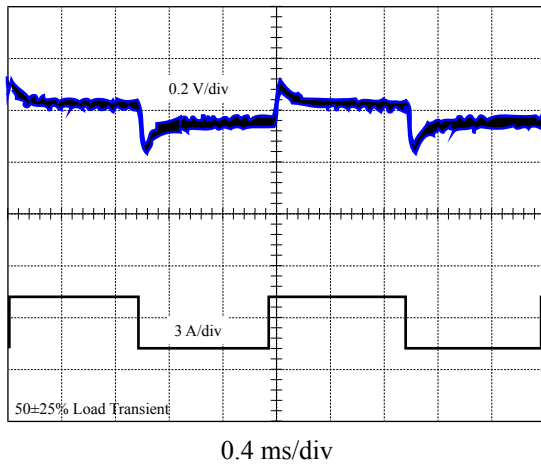

**Capacitive Loading (0 μF)**

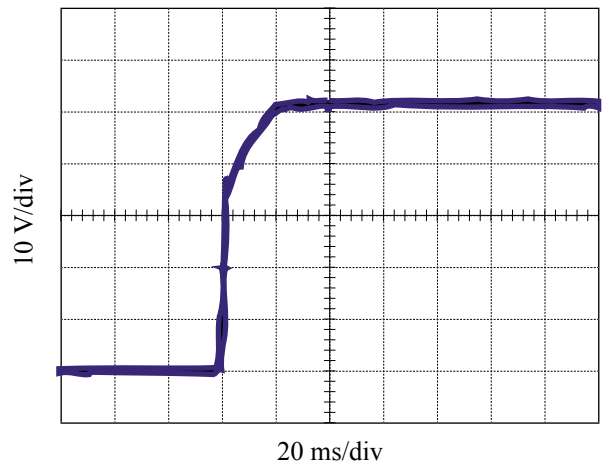

**Capacitive Loading (16,500 μF)**

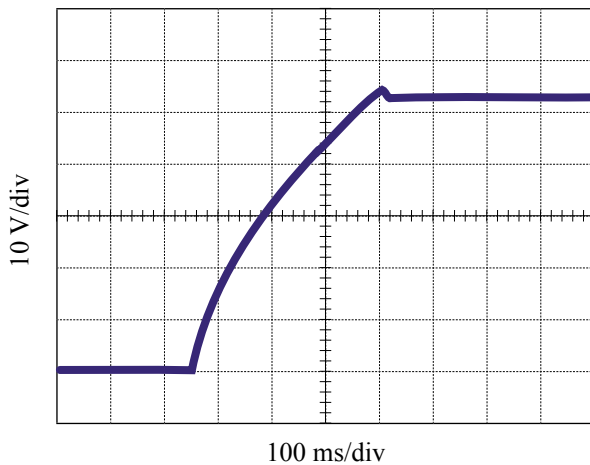

**Capacitive Loading (25,000 μF)**

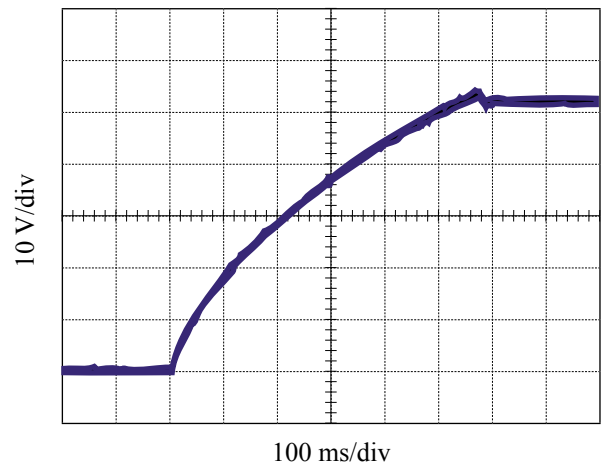

**Efficiency (typ)**

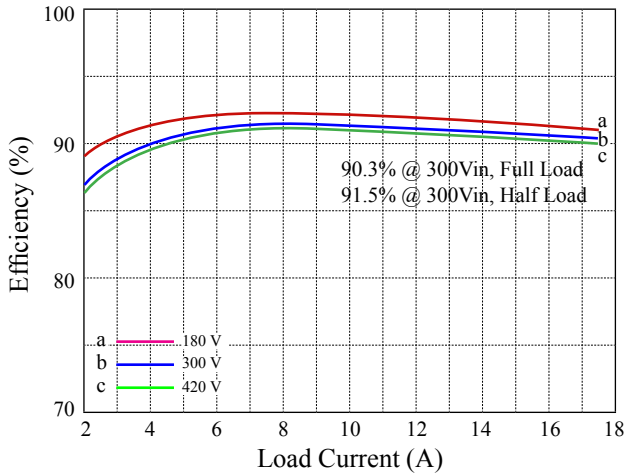

**Output Ripple/Noise (typ)**

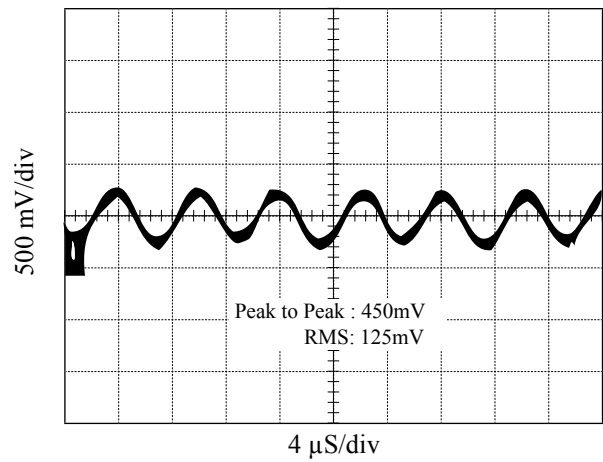

**Load Transient Response (typ)**

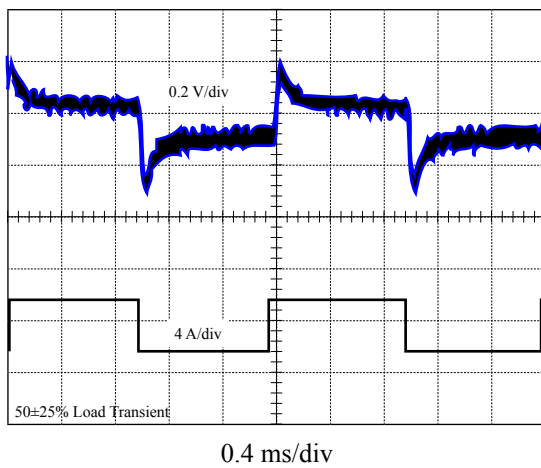

**Capacitive Loading (0  $\mu$ F)**

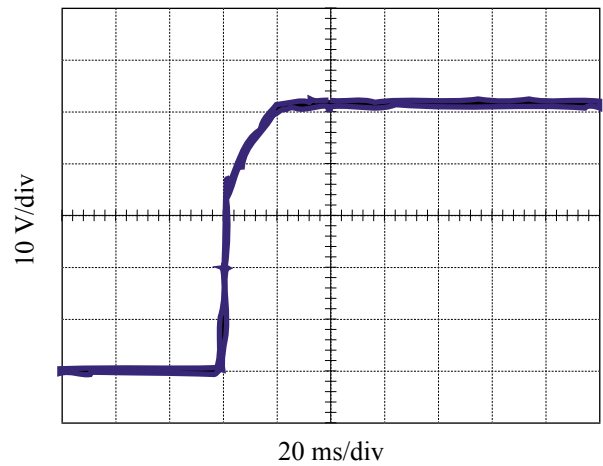

**Capacitive Loading (16,500  $\mu$ F)**

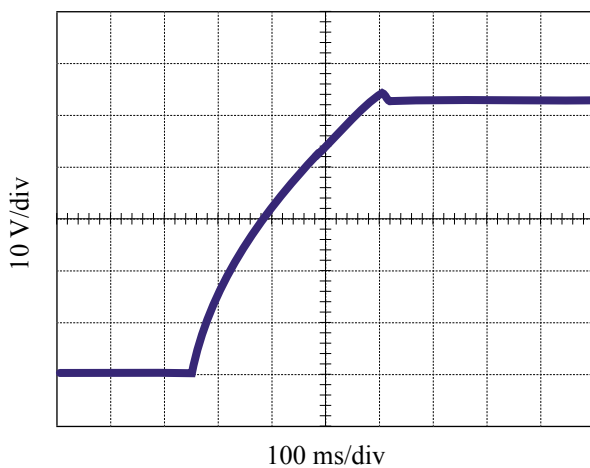

**Capacitive Loading (25,000  $\mu$ F)**

