

## Model 232CL4R Reversed RS-232 to Current Loop with Terminal Blocks

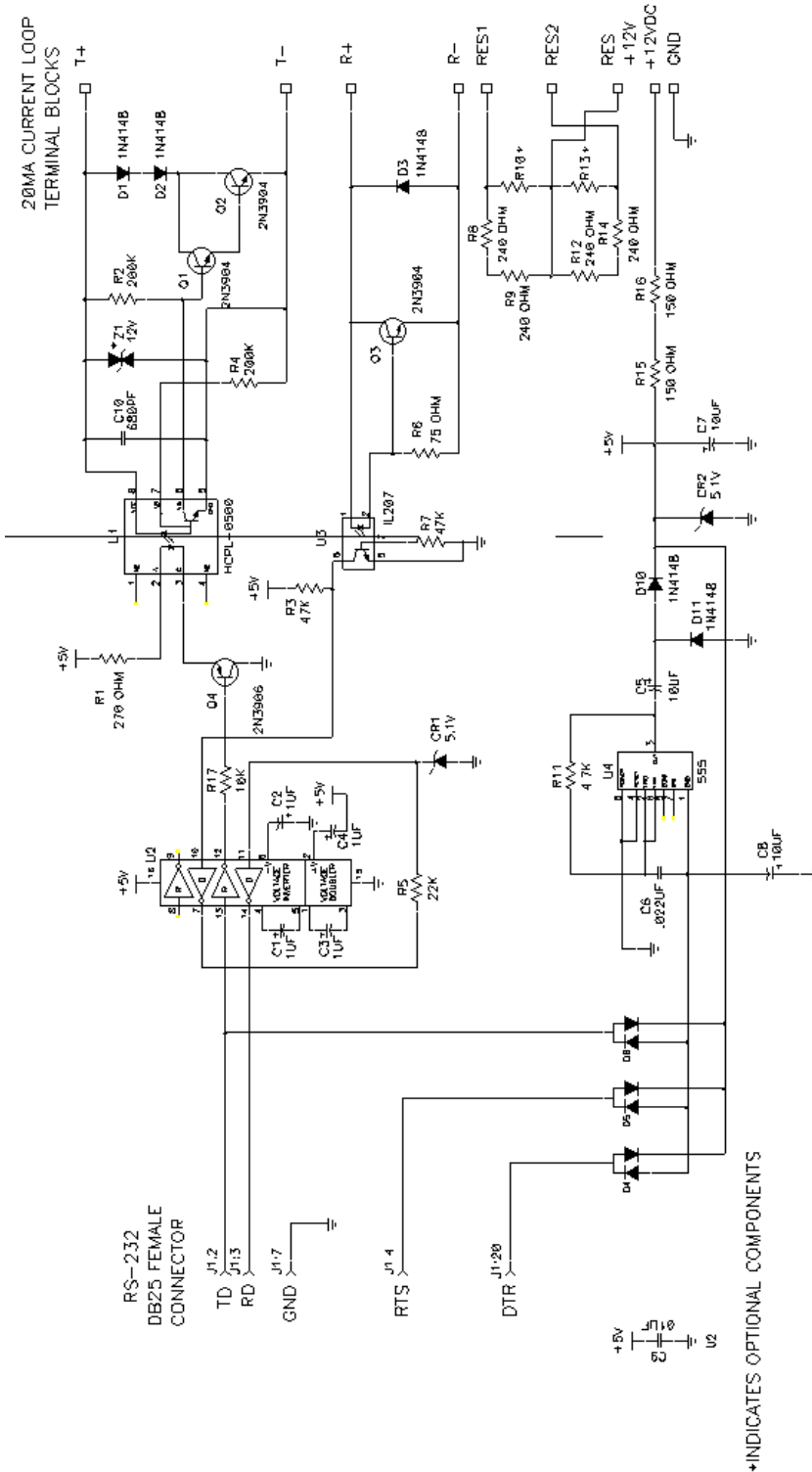

International Headquarters:

**B & B Electronics Mfg. Co.** 707 Dayton Road P.O. Box 1040 Ottawa, IL 61350 USA  
815-433-5100 Fax 433-5104 [www.bb-elec.com](http://www.bb-elec.com) [orders@bb-elec.com](mailto:orders@bb-elec.com) [support@bb-elec.com](mailto:support@bb-elec.com)

**B & B Electronics Ltd** Westlink Commercial Park Oranmore Co. Galway Ireland  
+353 91 792444 Fax +353 91 792445 [www.bb-europe.com](http://www.bb-europe.com) [orders@bb-elec.com](mailto:orders@bb-elec.com) [support@bb-europe.com](mailto:support@bb-europe.com)

**NOTE: When using an external supply, the supply should be connected only to specifically labeled power inputs (power jack, terminal block, etc.). Connecting an external power supply to the handshake lines may damage the unit. Contact technical support for more information on connecting an external power supply to the handshake lines.**

**DECLARATION OF CONFORMITY**

Manufacturer's Name: B&B Electronics Manufacturing Company  
Manufacturer's Address: P.O. Box 1040  
707 Dayton Road  
Ottawa, IL 61350 USA  
Model Number: 232CL4R  
Description: Reversed RS-232 to Current Loop Converter  
Type: Light industrial ITE equipment  
Application of Council Directive: 89/336/EEC  
Standards: EN 55022  
EN 61000-6-1  
EN 61000 (-4-2, -4-3, -4-4, -4-5, -4-6, -4-8, -4-11)



William H. Franklin III, Director of Engineering



International Headquarters:

**B&B Electronics Mfg. Co.** 707 Dayton Road P.O. Box 1040 Ottawa, IL 61350 USA  
815-433-5100 Fax 433-5104 [www.bb-elec.com](http://www.bb-elec.com) [orders@bb-elec.com](mailto:orders@bb-elec.com) [support@bb-elec.com](mailto:support@bb-elec.com)

**B&B Electronics Ltd** Westlink Commercial Park Oranmore Co. Galway Ireland  
+353 91 792444 Fax +353 91 792445 [www.bb-europe.com](http://www.bb-europe.com) [orders@bb-elec.com](mailto:orders@bb-elec.com) [support@bb-europe.com](mailto:support@bb-europe.com)